

# SLIMFIT

## MAN TGA / TGX

### 24 V



**Instrucciones de Montaje**  
*Mounting Instructions*  
**Instructions de Montage**  
*Montageanweisungen*  
**Istruzioni di Montaggio**

- ES
- EN
- FR
- GE
- IT

SLIMFIT	1003274153
Kit instalación	1003345643
Documento	1003345641

Gracias por su adquisición y por confiar en nuestra gama de productos. **SLIMFIT** es un equipo de aire acondicionado diseñado y fabricado por **Dirna Bergstrom** para ser utilizado en un vehículo a motor parado durante los períodos de descanso a la sombra y/o por la noche.

**SLIMFIT** está diseñado con la más avanzada tecnología para lograr un eficaz rendimiento, una reducción en el gasto de combustible y en las emisiones de CO<sub>2</sub> a la atmósfera. Son estas características lo que lo hace único en el mercado del aire acondicionado para vehículos.



**Lea atentamente este documento antes de instalar el producto.** Conserve este documento para futuras consultas. La documentación original ha sido escrita en español, por lo que el resto de idiomas son traducciones.

Tiene a su disposición todos los manuales del producto en sus versiones digital (PDF) en <https://www.bergstromspain.com/>

Cualquier operación de venta o de garantía está sometida a nuestras condiciones generales de venta en su versión más actualizada, publicada en nuestra página web <https://www.bergstromspain.com/>

### Explicación de símbolos



- **Advertencia:** Aviso de seguridad que informa sobre una situación, que de no evitarse, puede provocar lesiones graves o la muerte.



- **Peligro:** Riesgo de corte. Señala una situación que podría provocar un corte.



- **Peligro:** Riesgo de electrocución. Señala una situación que podría provocar una electrocución.



- **Aviso:** Aviso de seguridad que informa sobre una situación, que de no evitarse, puede provocar daños al equipo o a otros materiales.



- **Información:** Información adicional sobre la instalación o el manejo del producto.



- **Frágil:** Indica una situación en la que se debe operar con cuidado para no causar daños al equipo y a otros materiales.



### Explicación de responsabilidades

- **Dirna Bergstrom** declina toda responsabilidad ante los daños ocasionados en los siguientes casos:

- Daños en el producto debido a influencias mecánicas y sobretensiones.
- Modificaciones realizadas en el equipo sin el consentimiento expreso del fabricante.
- Utilización el equipo para fines no descritos en este documento.
- Una inadecuada manipulación o instalación del equipo.

- Queda prohibida la manipulación de los circuitos de gas refrigerante sin autorización expresa del fabricante.



### Advertencias durante el montaje

- La instalación, reparación y mantenimiento de este equipo de aire acondicionado solo puede ser realizada por aquel personal técnico que posea una formación suficiente en aire acondicionado para vehículos, posibles peligros y normas aplicables.

- Leer detenidamente las instrucciones de montaje antes de iniciar la instalación del equipo. Durante la instalación, seguir al pie de la letra las instrucciones indicadas.

- Al instalar el equipo de aire acondicionado en el techo se debe proteger la parte superior de la cabina con un paño o manta protectora para evitar posibles arañazos. Al instalar **SLIMFIT** en el techo hay que tener en cuenta que, normalmente, las cabinas que vienen provistas de escotilla, tienen una estructura suficiente para soportar el peso del equipo. Sin embargo, cuando no ocurra así y sea necesario realizar corte en el techo o incluso si en el caso de llevar escotilla el material no es lo suficientemente resistente (caso de techo de fibra, plástico, etc...) es el instalador el que debe decidir, **bajo su responsabilidad**, sobre la necesidad de reforzar el techo para evitar posibles deformaciones, roturas, entradas de agua, etc... habilitando los medios para que esto no ocurra.

- Desconectar la llave de contacto antes de iniciar la instalación del equipo.

- Desconectar la batería del vehículo antes de iniciar la instalación del equipo.

- Instale **SLIMFIT** de forma segura para evitar caídas.
- Utilizar las herramientas adecuadas para cada operación.
- Durante la instalación, asegurar la conexión de los componentes eléctricos, verificando su encaje correcto.
- Si en la instalación del equipo los cableados atraviesan paredes con bordes afilados, utilice conductos o guías para evitar que los cables se dañen.
- Si durante la instalación el equipo se inclina, o la cabina se abate con el equipo instalado sobre ella, deberá esperarse un mínimo de 60 minutos, desde que el equipo quede horizontal, antes de ponerlo en marcha.
- Equipo precargado con gas refrigerante r-134a.



- **Aviso importante:** Tenga la precaución al conectar el equipo de no invertir las polaridades. Si esto sucediera, la placa de mandos no se encenderá y el equipo no se pondrá en funcionamiento.



#### Herramientas necesarias para el montaje

- Juego de llaves Torx
- Juego de llaves Allen
- Llave fija 10, 13, 14
- Tijeras
- Flexómetro
- Destornillador



#### Uso adecuado del producto

- **SLIMFIT** es un equipo de aire acondicionado de techo apropiado para ser utilizado únicamente en camiones. No es adecuada su instalación y funcionamiento en maquinaria agrícola ni de construcción sujeta a intensas vibraciones.
- El uso no conforme al previsto anula la garantía del equipo y excluye de responsabilidad al fabricante.
- Si no está seguro de cómo utilizar **SLIMFIT**, revise el manual de usuario del producto.
- Si la temperatura en la cabina de su vehículo es muy elevada para el descanso, enfríe primero la cabina con el aire acondicionado de su vehículo durante algunos minutos y después ponga en marcha **SLIMFIT** para mantener la temperatura de confort.



#### Documentación relacionada

- Guía rápida: 1003115344
- Manual de usuario: 1003148646
- Listado de recambios: 1003345642
- Diagnóstico de averías: 1003148649

Dirna Bergstrom declara que el equipo **SLIMFIT** cumple con los requerimientos de las siguientes Directivas CE y que se han aplicado las normas y especificaciones técnicas armonizadas enumeradas a continuación:

- Directiva CE 2014/53/EU
- Directiva CE 2011/65/EU
- Directiva CE 2014/30/EU



Para vehículos TGX cabina XLX con spoiler no se puede instalar el equipo.

En vehículos con spoiler (\*) las modificaciones a realizar en el mismo **deben ser autorizadas por el cliente**, por lo que **dirna Bergstrom se exime de toda la responsabilidad** por la modificación del spoiler. En el caso de estar autorizadas las modificaciones que se deben realizar en el spoiler, se debe desmontar éste antes de comenzar la instalación.



**1** Desmontar tapa escotilla, los elementos de fijación y entregar éstos al cliente.



**2** Quitar los residuos sobrantes adheridas al techo antes de pegar la junta EPDM.

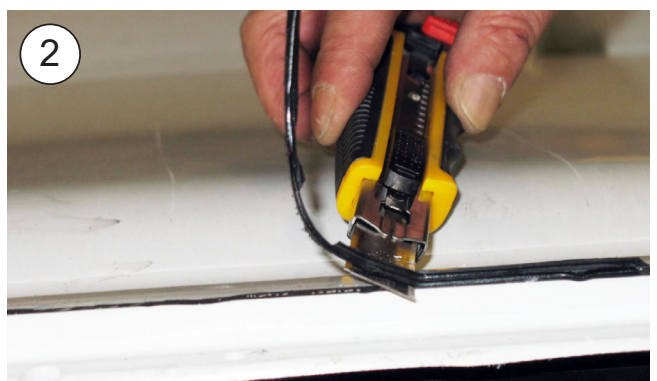

**3** Pegue la junta EPDM 40x40 alrededor del resalte del hueco de escotilla (*mirar el detalle para cortar los bordes finales de unión de la junta*).

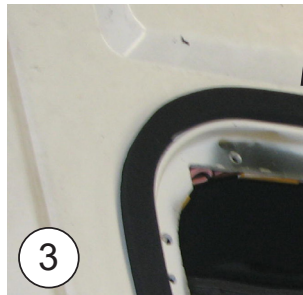

**COMO CORTAR LA JUNTA EPDM PARA EVITAR FILTRACIÓN DE AGUA EN LA CABINA**

- A- Pegar la junta, manteniendo 100 mm de papel protector por cada lado.
- B- Quitar los dos piezas de papel.
- C- Pegue presionado ambos finales.

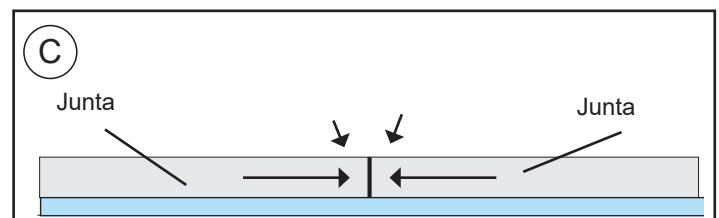
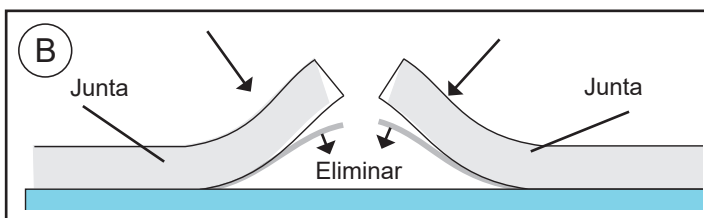
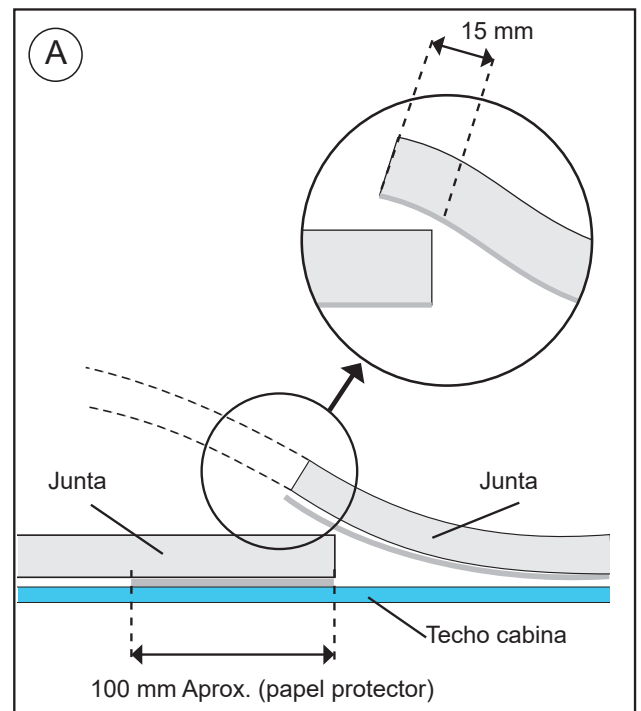

**4** Roscar (4) hexágonos M8 L=32 con arandela goma Ø 20, arandela plana Ø 8 en insertos de la base del equipo y apretar.

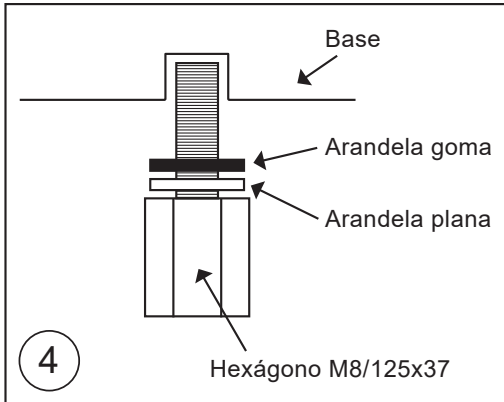
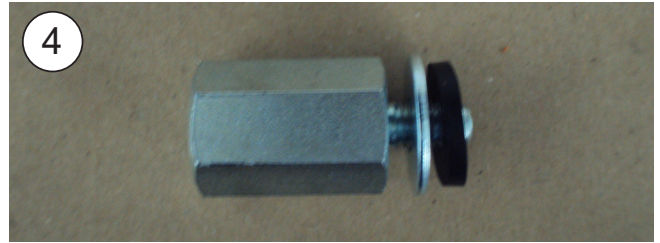

**5** Roscar (2) hexágonos M6/100x50 con arandela de goma Ø 18 y arandela plana Ø 6 ala ancha en insertos delanteros de la base y apretar.

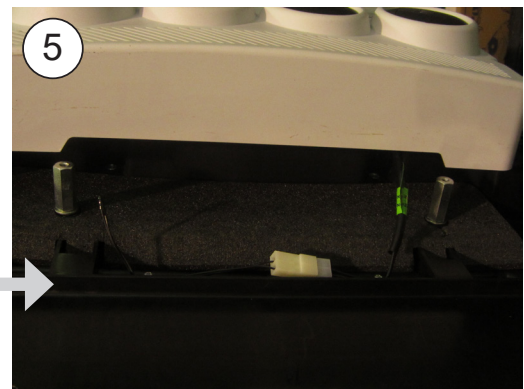
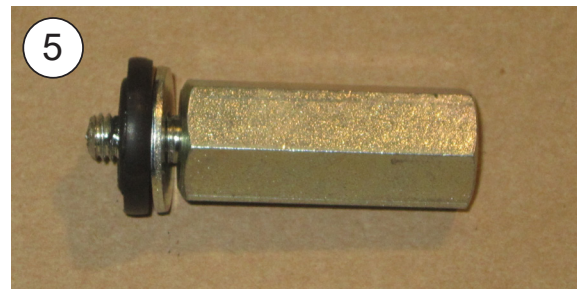

**6 EXTERIOR CABINA:**

Posicionar el **SLIMFIT** en el hueco de la escotilla sobre la junta EPDM.

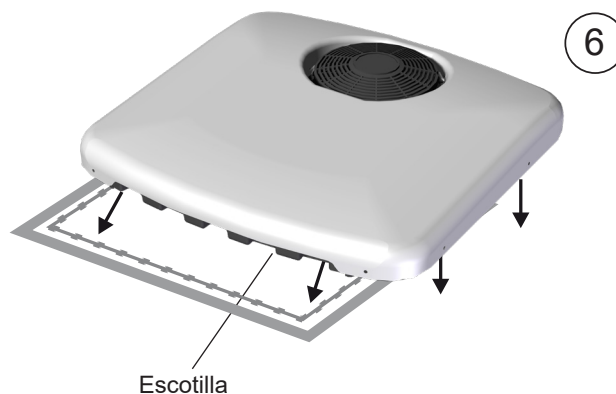

- 7** Posicionar soportes con (4) tornillos 8/125x55, (4) arandelas planas Ø 8 ala ancha y (4) arandelas grower Ø 8, roscando en hexágonos Ø 8.



- 8** Posicionar consola en el panel interior de distribución de aire y centrar equipo, para que la consola quede de la forma más idónea.

**¡Atención, verificar una vez centrado el equipo, la recirculación queda dentro del hueco de la escotilla, la base del equipo cubre por todos los lados la junta EPDM y los desagües quedan en el exterior de la junta EPDM!**



- 9** Apretar tornillos de fijación hasta que los soportes hagan tope con los hexágonos M8.

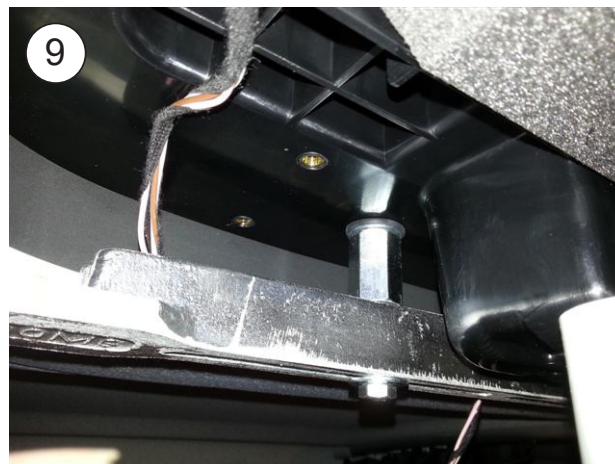

**10** Fijar consola con (4) tornillos 6/100x15 allen roscando en hexágonos M6 e insertos en la base.

**¡Atención, sacar cableados de las luces originales por los cortes de la consola!**



**11** Montar luces originales en la consola y colocar (4) tapones embellecedores para tapar tornillos M6 allen.





Vista explosionada hasta la fijación de los soportes

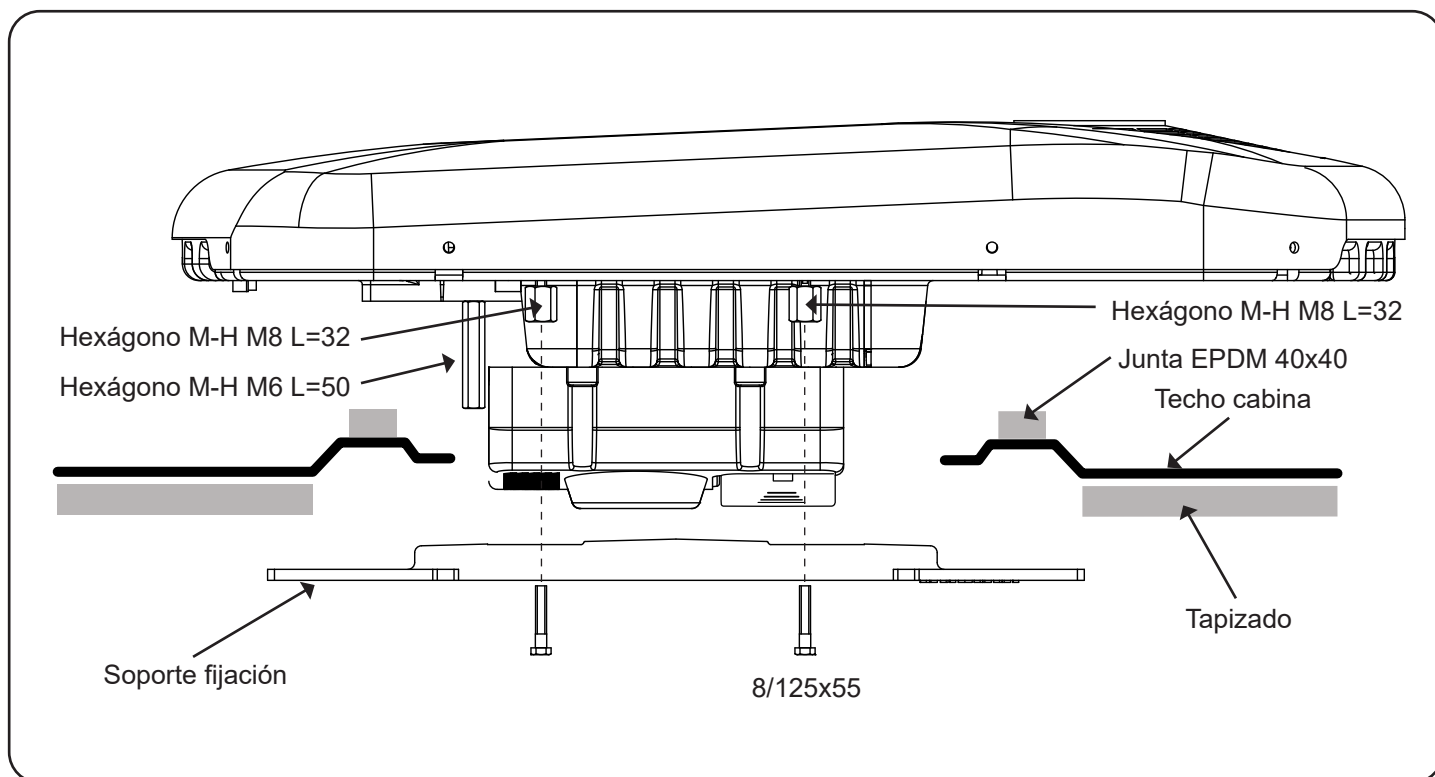

Vista explosionada lateral hasta la fijación de las consolas

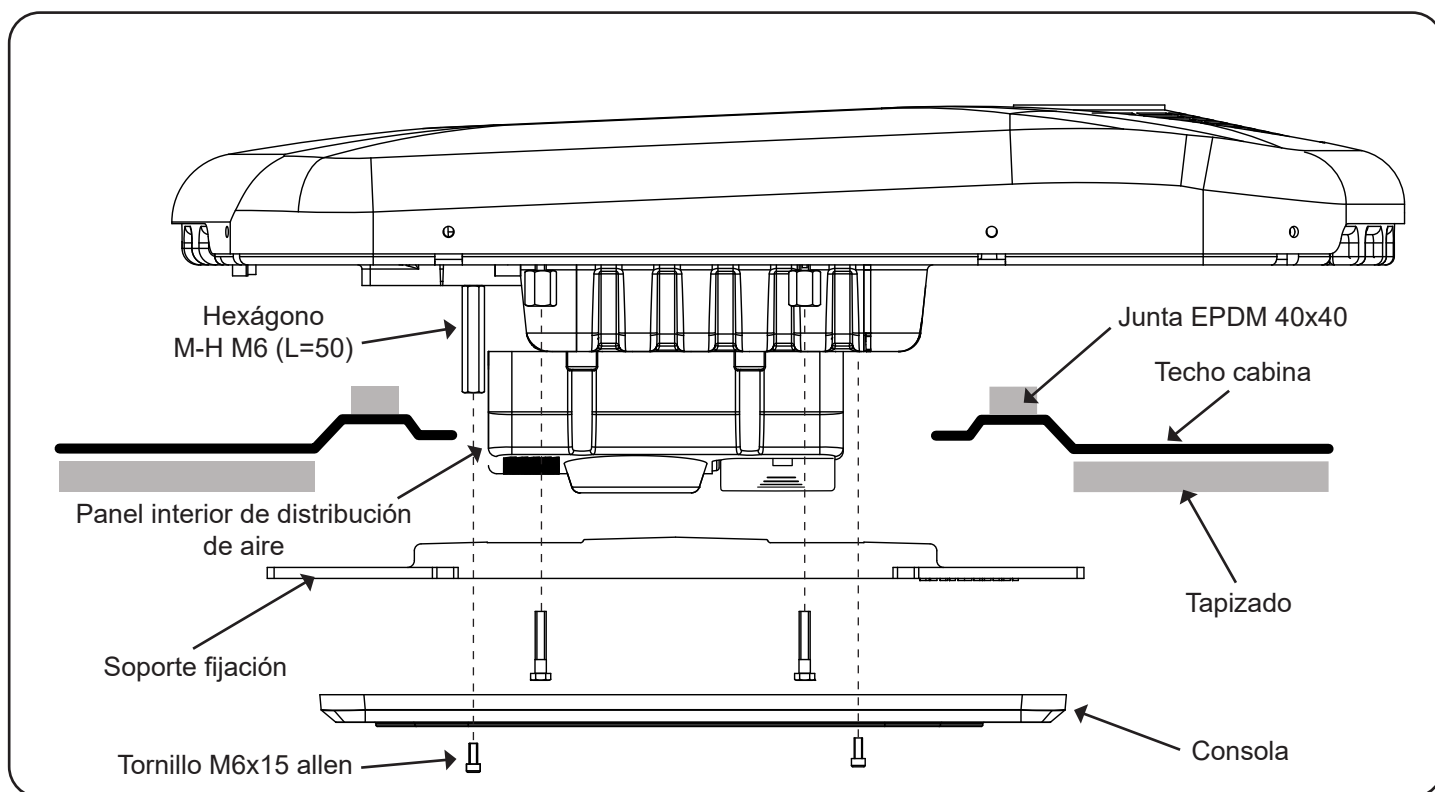

## Conexión cableado batería



**Nota:** Dependiendo del modelo de camión, existe la posibilidad de conectar el equipo en varios puntos de conexión.



**Atención:** Seguir las pautas de instalación eléctrica según indicaciones del fabricante.

**A** Conexión en caja de fusibles:

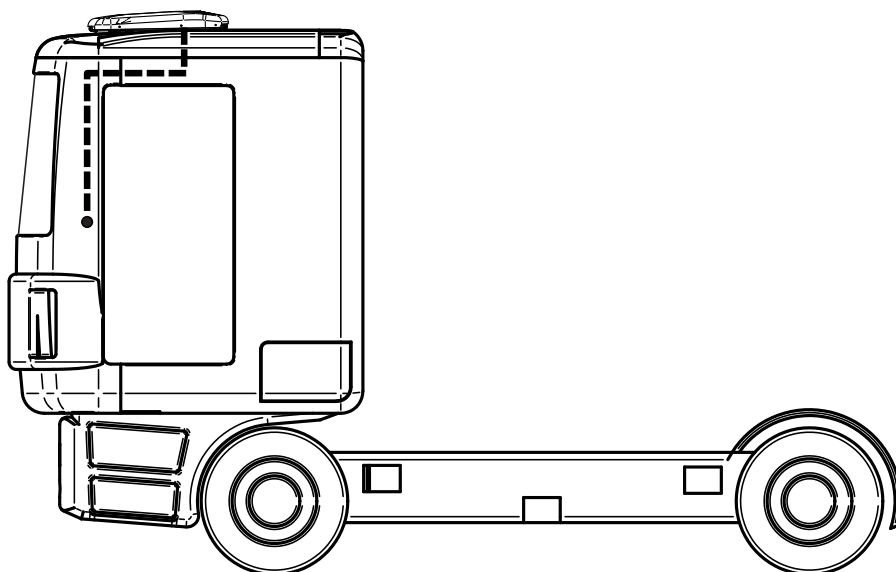

**B** Conexión en baterías:

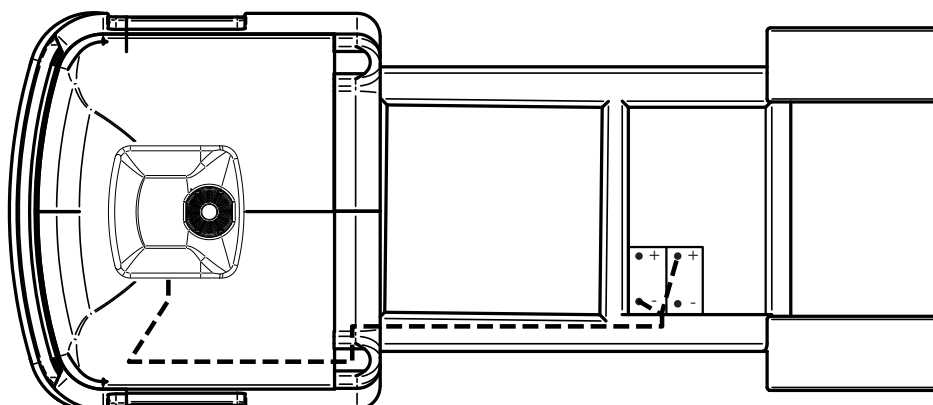

**C** Conexión en caja conexión parrilla delantera:

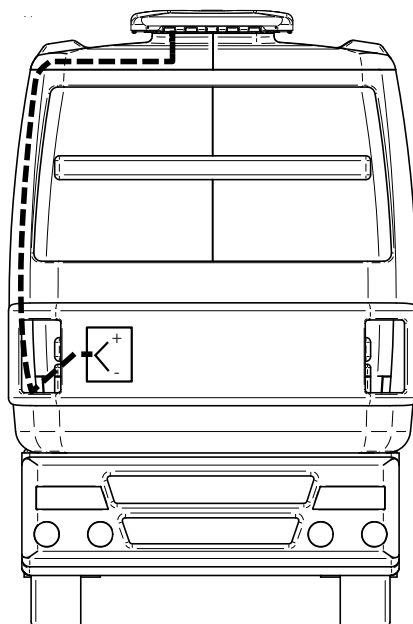

**Importante:** Para la puesta en marcha consultar el Manual del usuario.

Esquema eléctrico

¡AVISO IMPORTANTE!

Precaución de no invertir las polaridades al conectar el equipo. Si esto sucediera, el panel de control no se enciende y el equipo no funciona.

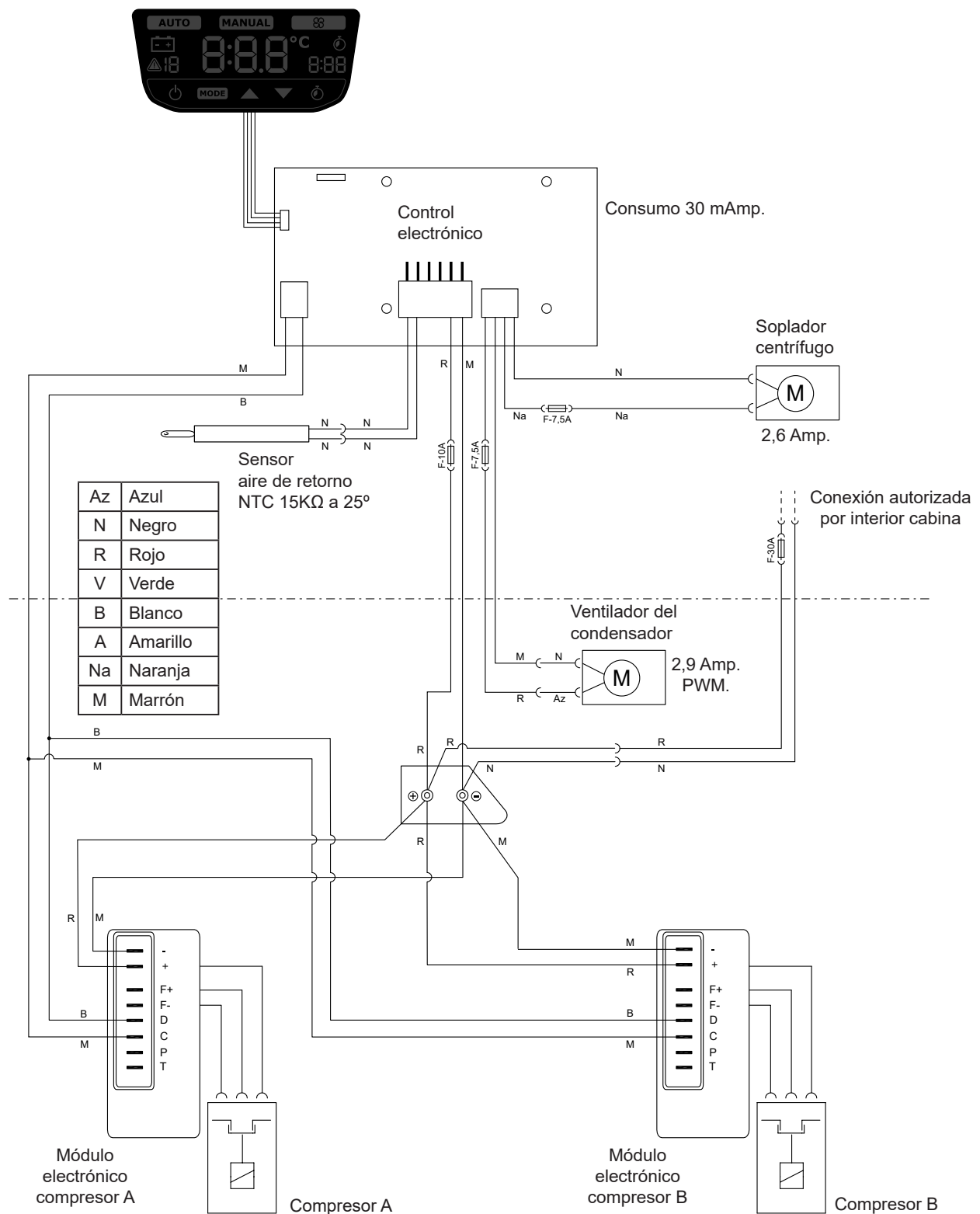

A series of horizontal dotted lines for writing, spanning the width of the page.

Thank you for placing your trust in our range of products. **SLIMFIT** is an air conditioning unit designed and manufactured by **Dirna Bergstrom** to run off a stationary vehicle's engine during rest periods in the shade and/or at night.

**SLIMFIT** is designed with cutting-edge technology to achieve high performance, reduced fuel consumption, and a lower level of CO<sub>2</sub> emissions. These are the features that make it unique on the vehicle air conditioning market.



**Read this document carefully before installing the product.** Keep this document for future reference. The original documentation was written in Spanish, all other languages are translations.

All product manuals are available in their digital versions (PDF) at

<https://www.bergstromspain.com/>

All sales and warranty transactions are subject to our general conditions of sale in their latest version, published on our website

<https://www.bergstromspain.com/>

### Explanation of symbols



- **Warning:** A safety warning indicating a situation which, if not avoided, could result in death or serious injury.



- **Danger:** Cutting risk. Indicates a situation that could lead to cutting.



- **Danger:** Risk of electrocution. Indicates a situation that could lead to electrocution.



- **Caution:** Safety warning informing about a situation, which if not avoided, could result in damage to the unit or other materials.



- **Information:** Additional information on the installation or handling of the product.



- **Fragile:** Indicates a situation in which care must be taken to avoid damage to the unit and other materials.



### Explanation of liability

- **Dirna Bergstrom** accepts no responsibility for damage caused in the following cases:

- Damage to the product due to mechanical influences and surges.
- Modifications made to the unit without the manufacturer's express consent.
- Use of the unit for purposes not described in this document.
- Improper handling or installation of the unit.

- It is forbidden to tamper with the refrigerant gas circuits without the manufacturer's express authorisation.



### Warnings during assembly

- The installation, repair and maintenance of this air conditioning unit may only be carried out by technical staff with sufficient training in vehicle air conditioning, possible dangers and applicable standards.

- Read the installation instructions carefully before starting to install the unit. During installation, follow the instructions carefully.

- When installing air conditioning equipment on roof, the upper cabin part must be protected with a cloth or a protective blanket to avoid possible scratches. When installing **SLIMFIT** on roof, take into account that, normally, cabins equipped with a hatch have a strong enough structure to hold equipment weight. However, if it is not the case and it is necessary to carry out a cut in the roof or, although it has a hatch, the material is not resistant enough (*if roof is made of fibre, plastic, etc...*), it is the installer who will have to decide, under his responsibility, if it is necessary to reinforce the roof to avoid possible deformations, breaks, water entries, etc., habitating the means required to stop it from occurring.

- Switch off the ignition key before starting to install the unit.

- Disconnect the vehicle's battery before starting to install the unit.

- Install **SLIMFIT** securely to prevent it from falling.

- Use the appropriate tools for each operation.

- During installation, ensure the connection of the electrical components, checking that they are fitted correctly.

- If during installation of the unit the cables pass through walls with sharp edges, use conduits or guides to prevent damage to the cables.
- If during installation the unit is tilted, or the cab is tilted with the unit installed on top, you must wait at least 60 minutes after placing the unit in horizontal position before it is started.
- Unit pre-charged with r-134a refrigerant gas.



- **Important:** When connecting the unit make sure the polarities are not reversed. If this happens, the control board will not switch on and the unit will not operate.



### Tools required for assembly

- Torx wrenches set.
- Allen wrenches set.
- Open-jawed spanner 10, 13, 14.
- Scissors.
- Flexo-meter.
- Screwdriver.



### Proper use of the product

- **SLIMFIT** is a roof-mounted air conditioning unit suitable only for use in trucks. It is not suitable for installation and operation in agricultural or construction machinery subject to intense vibrations.
- Non-intended use will void the unit's warranty and exempts the manufacturer from any responsibility.
- If you are not sure how to use **SLIMFIT**, read the product's user manual.
- If the temperature in your vehicle's cab is too high for rest, first cool the cab with your vehicle's air conditioning for a few minutes and then run **SLIMFIT** to maintain the comfort temperature.



### Associated documentation

- Quick guide: 1003115344
- User manual: 1003148646
- List of spare parts: 1003345642
- Troubleshooting: 1003148649

**Dirna Bergstrom** declares that the **SLIMFIT** unit complies with the requirements of the following EC Directives and that the harmonised standards and technical specifications listed below have been applied:

- EC Directive 2014/53/EU
- EC Directive 2011/65/EU
- EC Directive 2014/30/EU



**The unit cannot be installed in vehicles with TGX cabin XLX with spoiler.**

In vehicles fitted with a spoiler (\*), all modifications **must be authorised by the customer**, to which end **dirna Bergstrom shall be released from any liability** in the event of modification of the spoiler. Whenever changes to the spoiler have been authorised, the spoiler must be taken down before starting installation.



**1** Remove the spoiler. Dismount the hatch cover and the attachment elements, and hand them over to the customer.



**2** Remove any excess on the ceiling before attaching the EPDM seal.





**3** Attach the EPDM 40x40 seal around the hatch gap ridge (see the details to cut the ends of the seal joint).

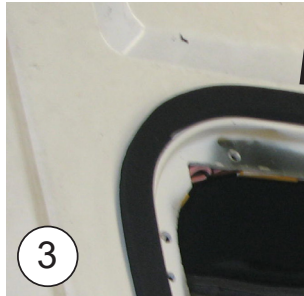

**!** **HOW TO CUT THE EPDM SEAL TO PREVENT WATER FROM DRIPPING IN THE CABIN**

**A-** Attach the seal, keeping 100 mm of protection paper on each side.

**B-** Remove the two pieces of paper.

**C-** Attach by pressing both ends.

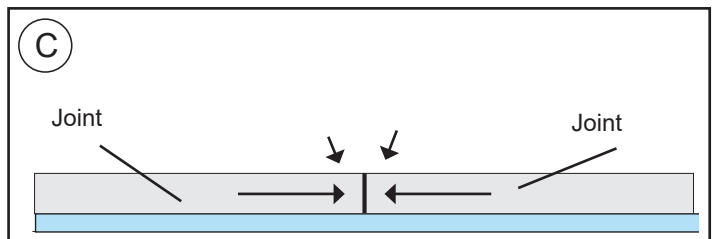
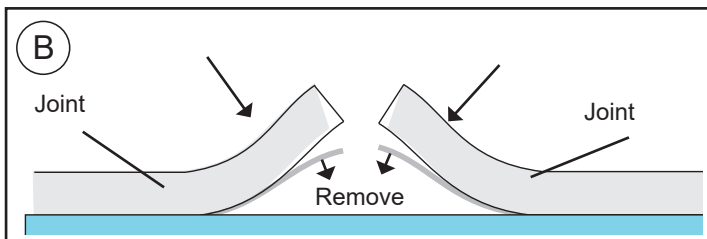
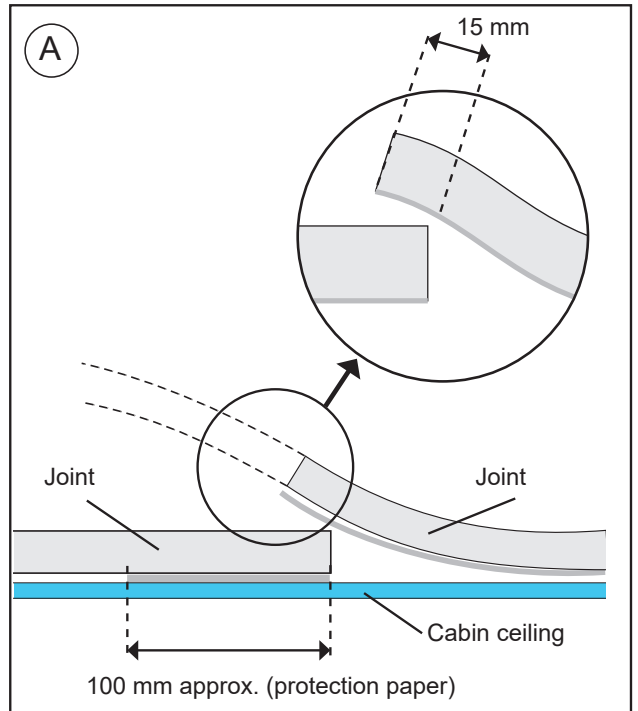

**4** Screw (4) M8 L=32 hexagons with Ø20 rubber washer and Ø8 flat washer on the inserts of the base and tighten.

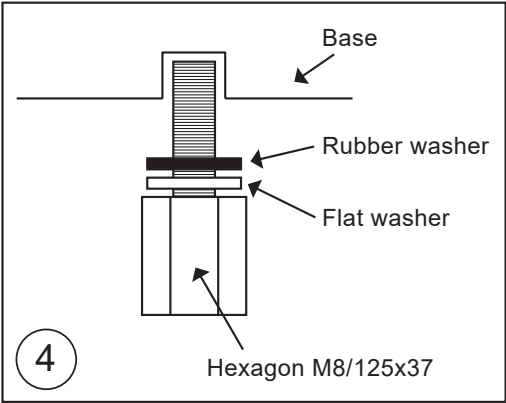

**5** Screw (2) M6/100x50 hexagons with Ø18 rubber washer and Ø6 wide-rimmed flat washer on the front inserts of the base and tighten.

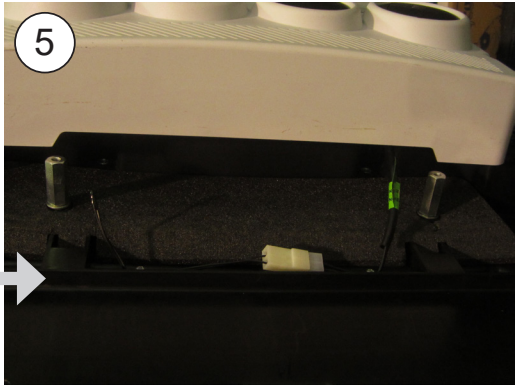
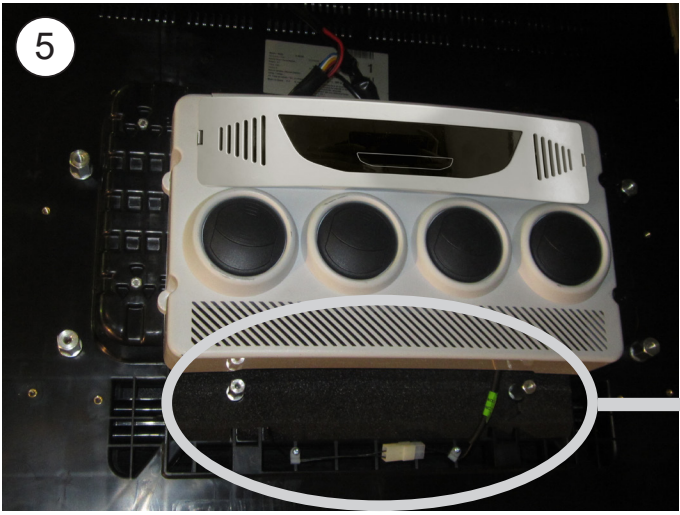
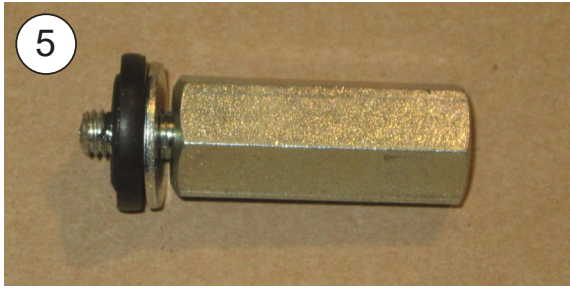

**6 CABIN EXTERIOR:**

Position the **SLIMFIT** in the hatch on the EPDM seal.

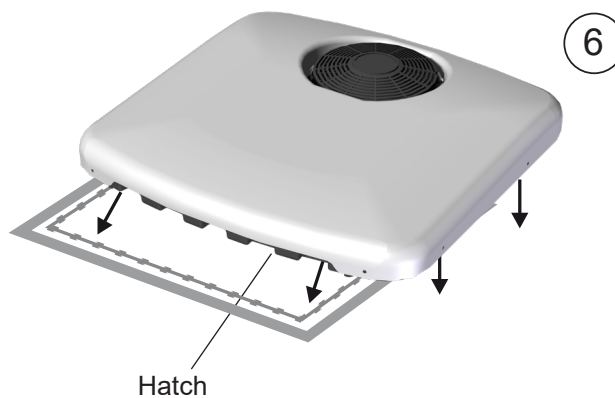

**7** Position the mounts with (4) 8/125x55 screws, (4) Ø8 wide-rimmed flat washers and (4) Ø8 grower washers, screwing on Ø8 hexagons.



**8** Position the console in the interior air distribution panel and align the unit to ensure the console is in the ideal position.

**Take care to check that recirculation is inside the hatch gap, the base of the unit covers the EPDM seal on all sides and the water run-offs are on the outside of the EPDM seal once the unit is aligned.**



**9** Secure the fastening screws until the mounts come into contact with the M8 hexagons.

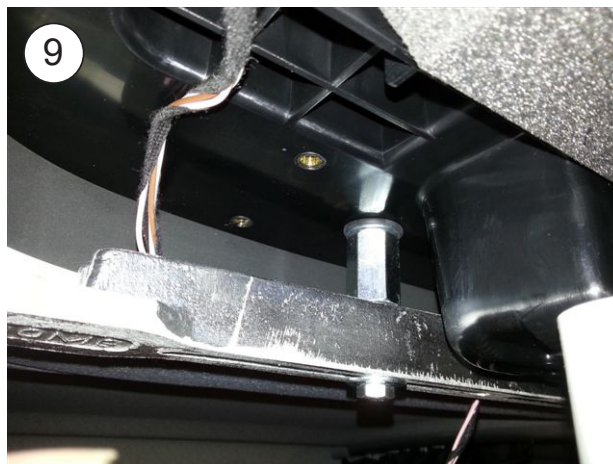

**10** Secure the console with (4) 6/100x15 Allen screws, screwing on M6 hexagons and inserts on the base.

**Take care to remove the original light wiring through the cuts in the console.**



**11** Mount the original lights on the console and position (4) decorative caps to cover the M6 Allen screws.

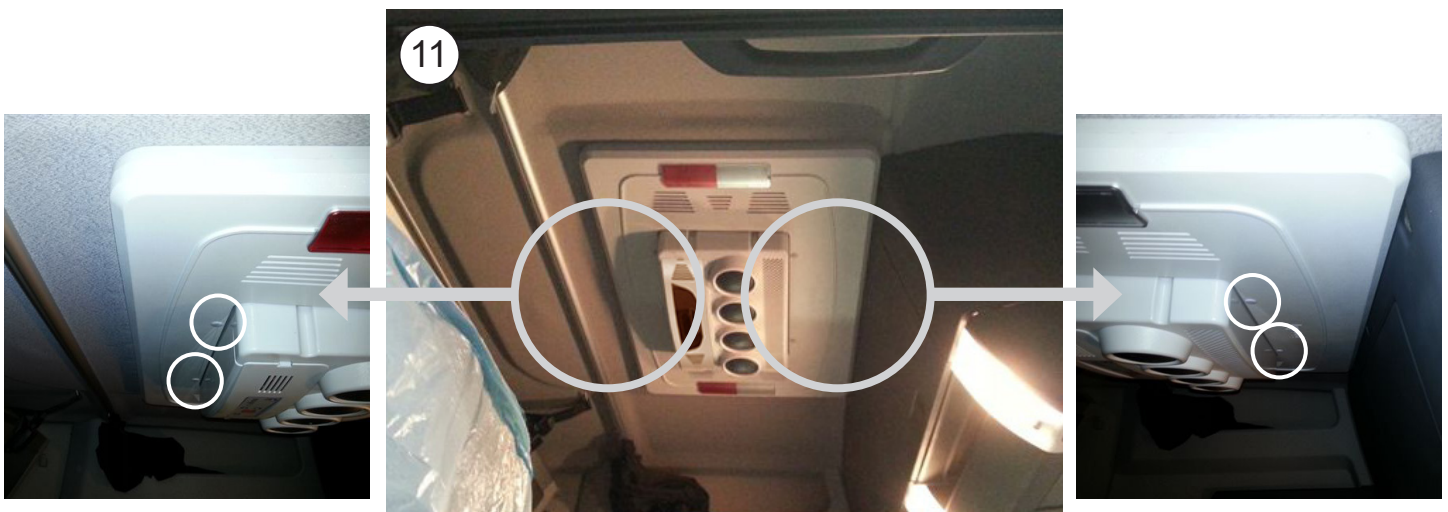

Exploded view through to fastening mount

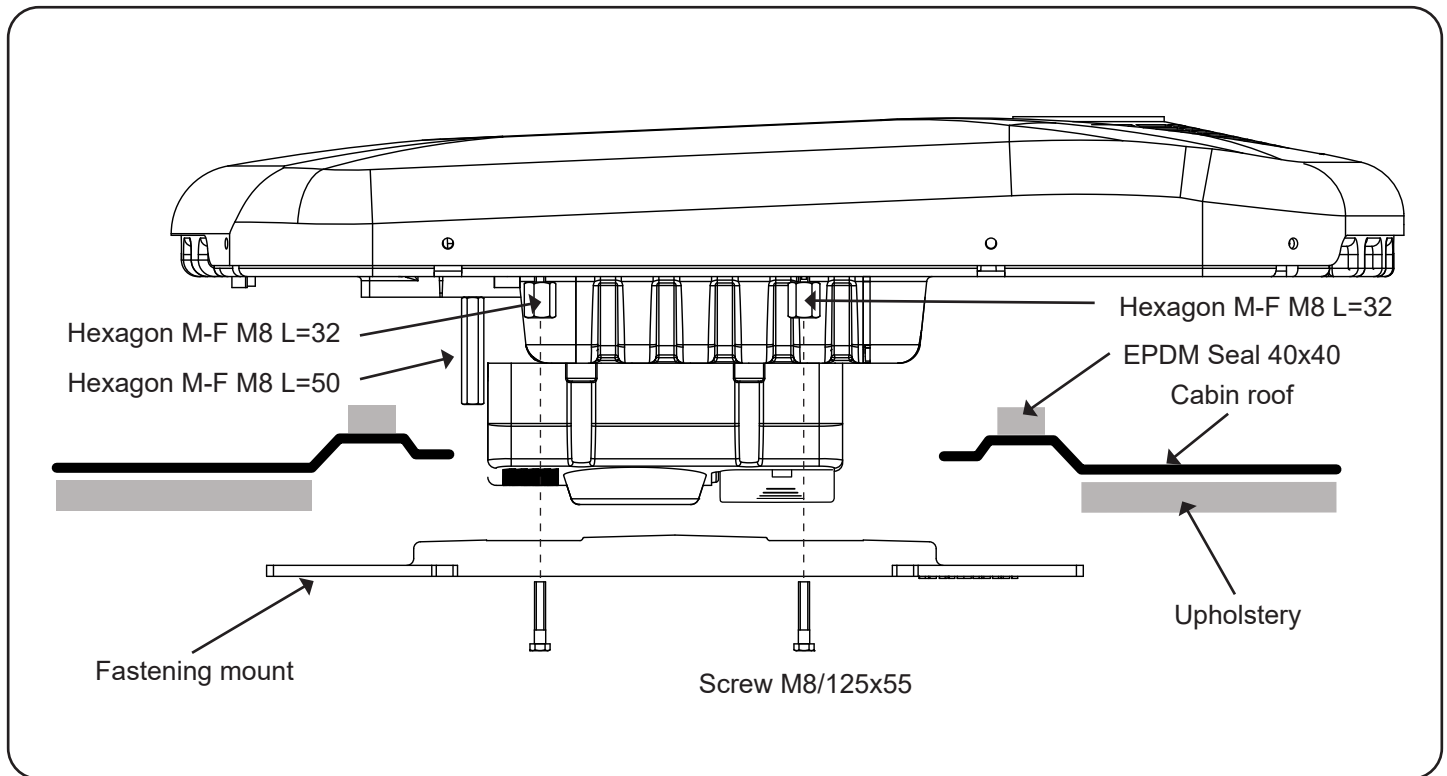

Exploded view through to console fastening

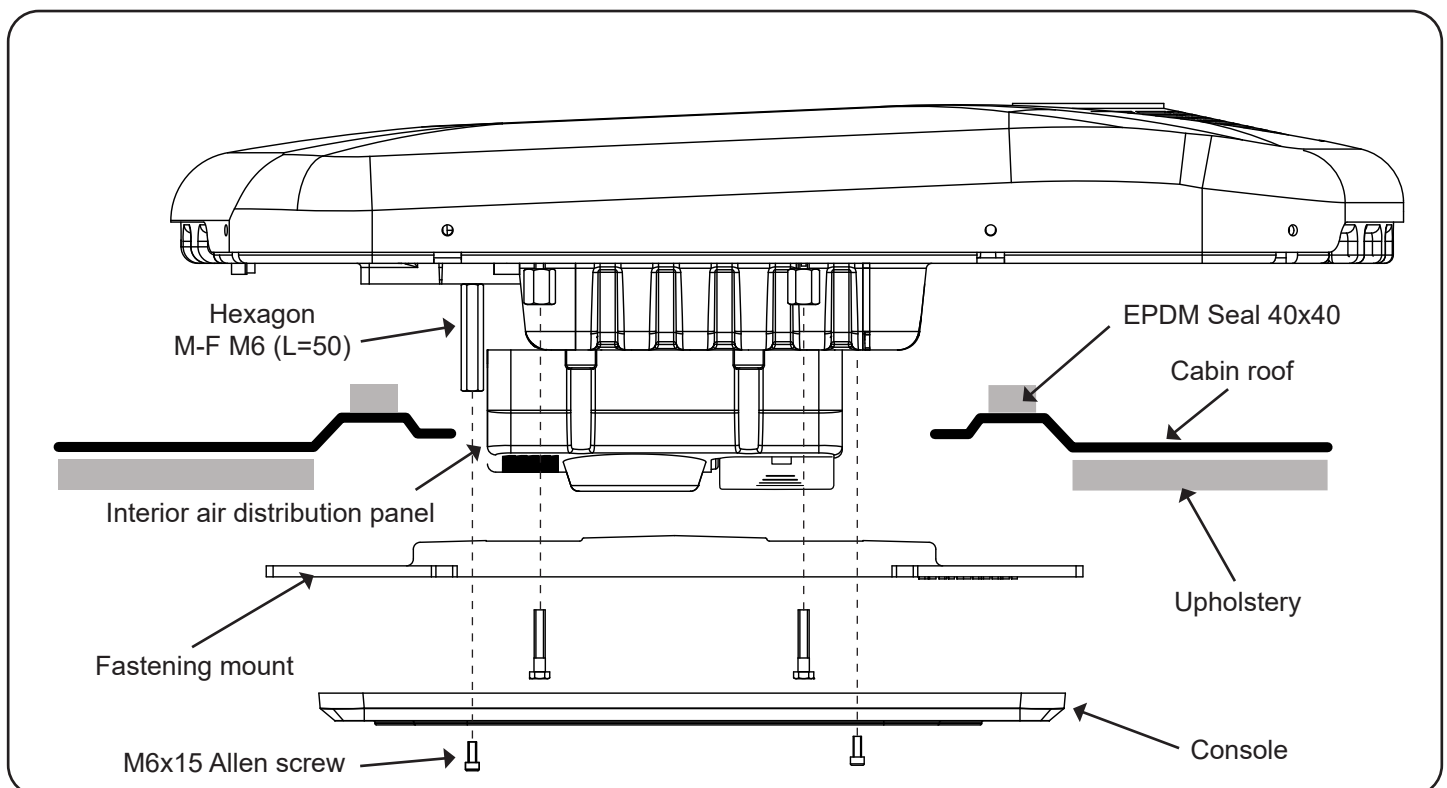

## Battery wire connection



**Note:** Depending on the model of truck, the unit can be connected at several connection points.



**Attention:** Follow the electrical installation guidelines in accordance with the manufacturer's instructions.

**A**

Connection in fuse box:

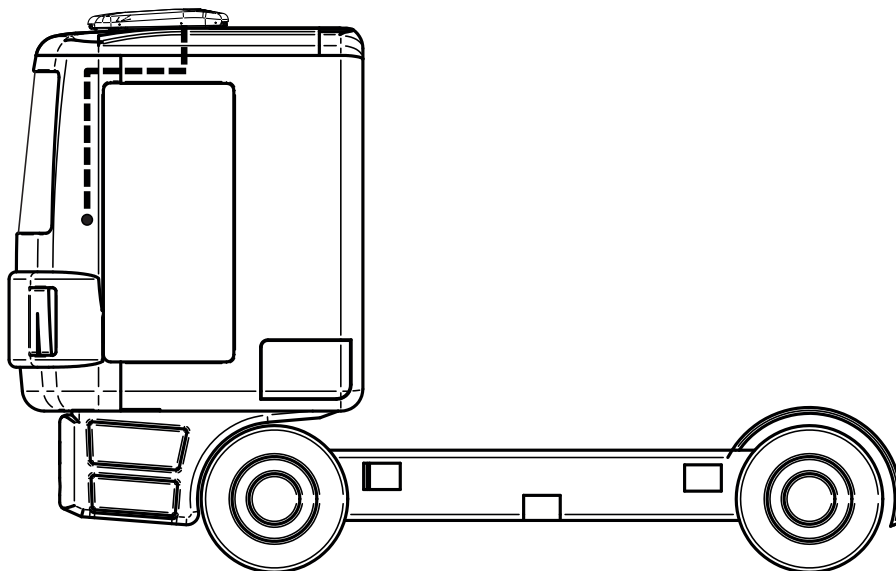

**B**

Battery connection:

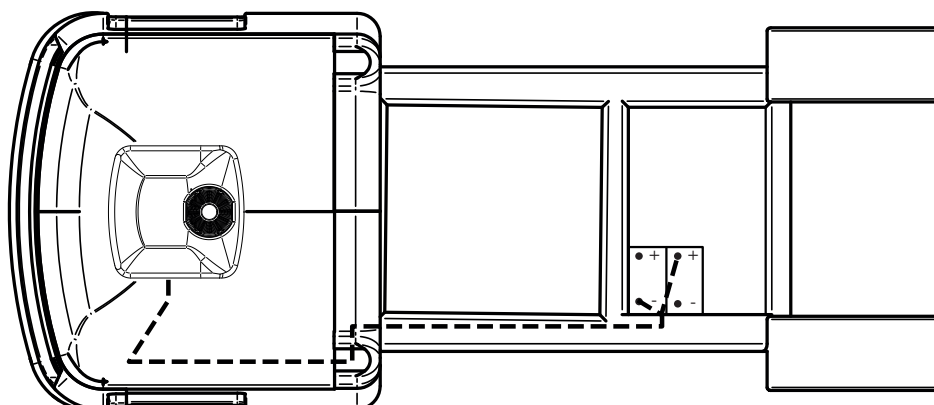

**C** Connection in front grille connection box:

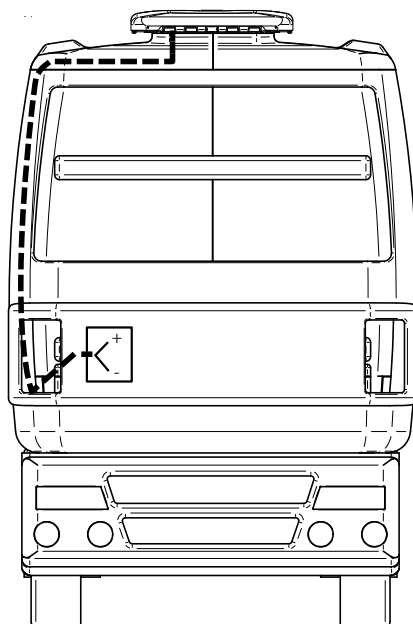

**Important: Please consult User's Guide before starting.**

Wiring diagram

**IMPORTANT NOTE!**

**Take care** not to invert polarities when connecting the unit to the power supply. If this were to happen, the plate would not come on and the unit would not work.

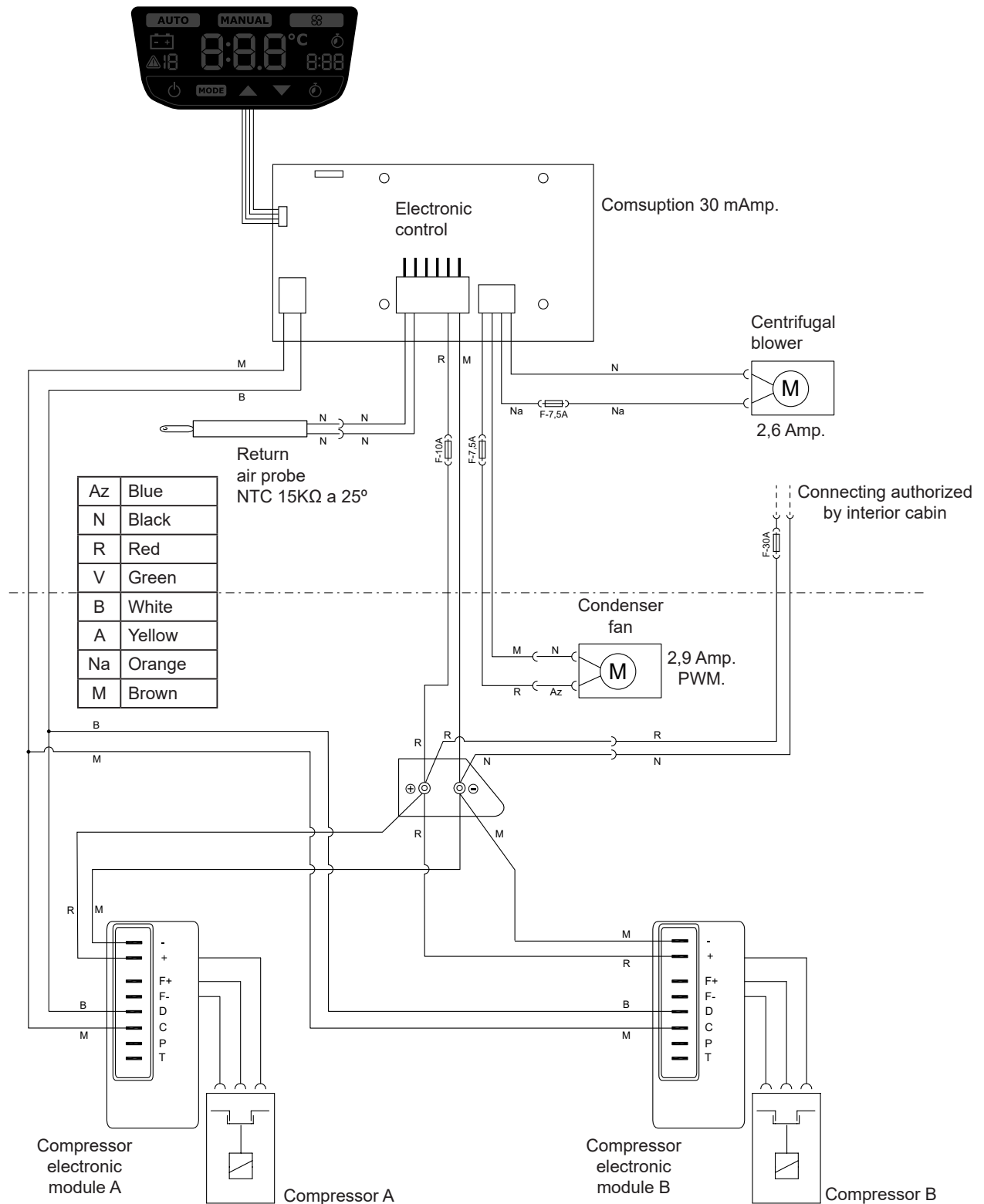



Lined area with multiple horizontal dotted lines for writing or drawing.

Nous vous remercions de votre achat et de la confiance témoignée à notre gamme de produits. **SLIMFIT** est une unité de climatisation conçue et fabriquée par **Dirna Bergstrom** pour une utilisation dans un véhicule avec le moteur à l'arrêt pendant les périodes de repos à l'ombre et/ou la nuit.

**SLIMFIT** est conçue avec la technologie la plus avancée pour obtenir des performances efficaces, une consommation réduite de carburant et diminuer les émissions de CO<sub>2</sub> dans l'atmosphère. Grâce à ces particularités, elle est unique sur le marché de la climatisation pour véhicules.



**Veillez lire attentivement ce document avant d'installer le produit.** Conservez ce document pour toute référence ultérieure. La documentation d'origine a été rédigée en espagnol, les autres langues sont donc des traductions.

Vous avez à votre disposition tous les manuels des produits dans leurs versions numériques (PDF) sur <https://www.bergstromspain.com/>

Toute opération de vente ou de garantie est soumise à nos conditions générales de vente dans leur version la plus à jour, publiée sur notre site Web <https://www.bergstromspain.com/>

### Explication des symboles



- **Mise en garde** : Avis de sécurité informant d'une situation qui, si elle n'est pas évitée, pourrait conduire à des blessures graves ou la mort.



- **Danger** : Risque de coupure. Signale une situation qui pourrait conduire à une coupure.



- **Danger** : Risque d'électrocution. Signale une situation qui pourrait conduire à une électrocution.



- **Avertissement** : Avis de sécurité informant d'une situation qui, si elle n'est pas évitée, pourrait entraîner des dommages matériels (équipement ou autre).



- **Information** : Information complémentaire sur l'installation ou la manipulation du produit.



- **Fragile** : Indique une situation dans laquelle il faut procéder avec précaution afin de ne pas endommager l'équipement ou d'autre matériel.



### Explication des responsabilités

- **Dirna Bergstrom** décline toute responsabilité en termes de dommages causés dans les cas suivants :

- Dommages au produit dus à des influences mécaniques et à des surtensions.
- Modifications apportées à l'équipement sans le consentement exprès du fabricant.
- Utilisation de l'équipement à des fins non décrites dans ce document.
- Manipulation ou installation inappropriée de l'équipement.

- La manipulation des circuits de gaz réfrigérant sans autorisation expresse du fabricant est interdite.



### Mises en garde au cours du montage

- L'installation, la réparation et l'entretien de cet équipement de climatisation ne peuvent être réalisés que par un personnel technique suffisamment formé sur la climatisation des véhicules, les dangers éventuels et les normes applicables.
- Lire attentivement les consignes de montage avant de commencer l'installation de l'équipement. Pendant l'installation, suivre au pied de la lettre les consignes indiquées.
- Lors de l'installation de l'appareil d'air conditionné sur le toit, il faudra protéger la partie supérieure de la cabine avec un linge ou une couverture de protection afin d'éviter les éventuelles égratignures. Durant l'installation du **SLIMFIT**, tenir compte du fait que normalement les cabines pourvues d'écouille possède une structure suffisamment solide pour supporter le poids de l'appareil. Cependant, si ce n'est pas le cas et qu'il est nécessaire de découper le toit ou même si disposant d'écouille, la structure n'est pas suffisamment rigide (si elle était en fibre, plastique, etc.) il appartiendra à l'installateur de décider s'il faut renforcer le toit pour éviter toute déformation, rupture ou voie d'eau, etc., et prendre les mesures nécessaires à cet effet.
- Débrancher la clé de contact avant de commencer l'installation de l'équipement.
- Débrancher la batterie du véhicule avant de commencer l'installation de l'équipement.
- Installez **SLIMFIT** en toute sécurité afin d'éviter les chutes.

- Utiliser les outils appropriés à chaque opération.
- Pendant l'installation, s'assurer du raccordement des composants électriques en vérifiant leur bon ajustement.
- Si lors de l'installation de l'équipement, les câbles traversent des murs à arêtes vives, utilisez des conduits ou des dispositifs de guidage, afin d'éviter l'endommagement des câbles.
- Si pendant son installation, l'équipement s'incline ou la cabine se rabat avec l'équipement installé dessus, attendez au moins 60 minutes, à compter du moment où l'équipement est à l'horizontale, avant de le mettre en marche.
- Équipement préchargé en gaz réfrigérant r-134a.



- **Avertissement important** : Faites attention lors du raccordement de l'équipement à ne pas inverser les polarités. Si cela se produit, la carte de commande ne s'allumera pas et l'équipement ne se mettra pas en marche.



#### Outils requis pour le montage

- Jeu de clés Torx.
- Jeu de clés Allen.
- Clé fixe 10, 13, 14.
- Ciseaux.
- Mètre.
- Tournevis.

#### Utilisation appropriée du produit

- **SLIMFIT** est une unité de climatisation de toit destinée à être utilisée dans les camions uniquement. Il n'est pas apte pour être installé ou fonctionner sur des machines agricoles ou de construction soumises à des vibrations intenses.
- L'utilisation non conforme à l'usage prévu annule la garantie de l'équipement et exclut la responsabilité du fabricant.
- Si vous n'êtes pas sûr de comment utiliser **SLIMFIT**, consultez le mode d'emploi du produit.
- Si la température dans la cabine de votre véhicule est trop élevée pour le repos, refroidissez d'abord la cabine avec la

climatisation de votre véhicule pendant quelques minutes, puis mettez le **SLIMFIT** en marche afin de maintenir une température confortable.



#### Documentation connexe

- Guide rapide : 1003115344
- Mode d'emploi : 1003148646
- Liste de pièces de rechange : 1003345642
- Diagnostic de pannes : 1003148649

**Dirna Bergstrom** déclare que l'équipement **SLIMFIT** satisfait aux exigences des Directives CE suivantes, et que les normes et spécifications techniques harmonisées énumérées ci-dessous ont été appliquées :

- Directive CE 2014/53/UE
- Directive CE 2011/65/UE
- Directive CE 2014/30/UE



Sur les véhicules TGX cabine XLX avec spoiler, il n'est pas possible d'installer l'appareil.

Sur les véhicules avec spoiler (\*) les modifications à y réaliser **devront être autorisées par le client**, par conséquent, **dirna Bergstrom décline toute responsabilité** de la modification du spoiler. Si les modifications à réaliser sur le spoiler sont autorisées, il faudra le démonter avant de commencer l'installation.



- 1** Démontez le spoiler. Démontez couvercle trappe, les éléments de fixation et les remettre au client.



- 2** Retirez les résidus excédants, adhérents au plafond avant de coller le joint EPDM.



**3** Coller le Joint EPDM 40x40 autour de la saillie de la cavité de la trappe (voir le détail pour découper les bords finals d'union du joint).

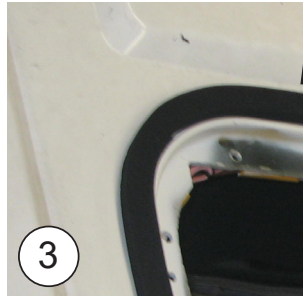

**!** **COMMENT COUPER LE JOINT EPDM POUR EVITER LA FILTRATION D'EAU DANS LA CABINE**

**A-** Coller le joint, en maintenant 100 mm de papier protecteur de chaque côté.

**B-** Retirer les deux pièces de papier.

**C-** Coller en faisant pression sur les deux extrémités.

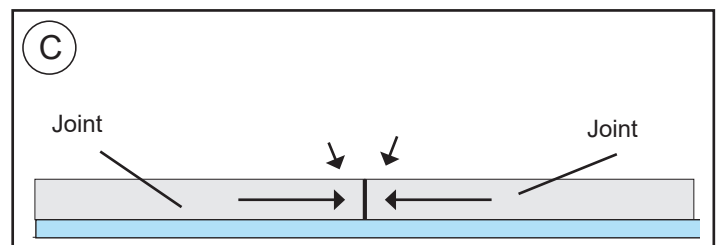
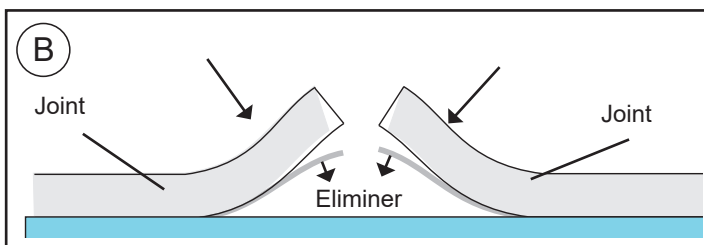
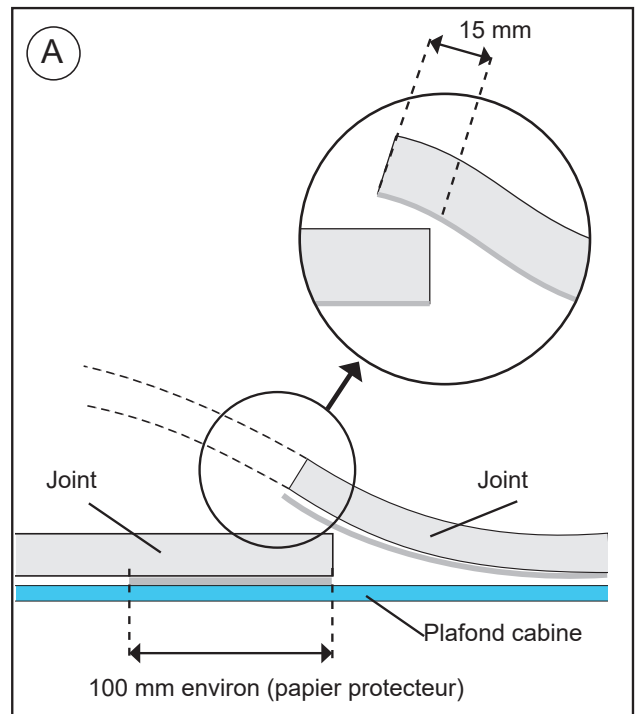

- 4** Visser (4) hexagones M8 L=32 avec la rondelle en caoutchouc Ø 20, la rondelle plate Ø 8 sur les inserts de la base et serrer.

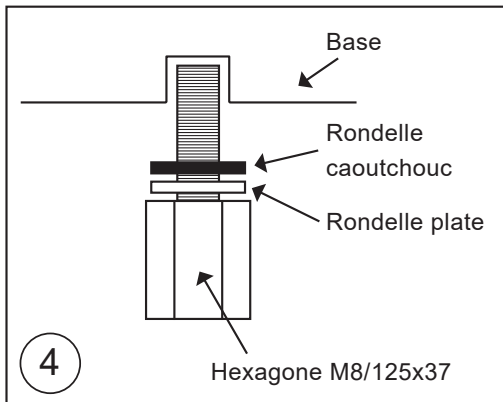

- 5** Visser (2) hexagones M6/100x50 avec rondelle de caoutchouc Ø 18 et rondelle plate Ø 6 large sur les inserts avant de la base et serrer.

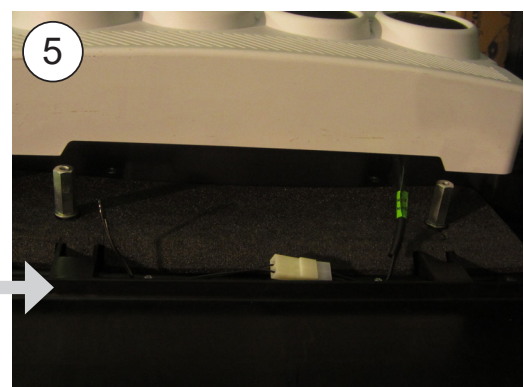
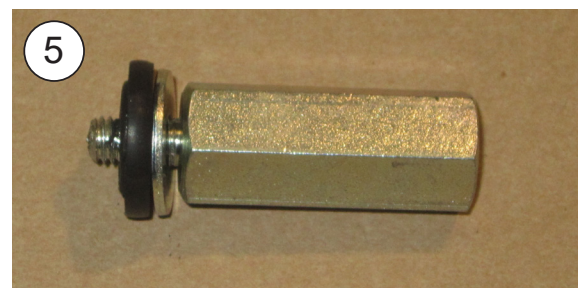

**6 EXTERIEUR CABINE:**

Positionner le **SLIMFIT** dans l'espace de l'écouille sur le joint EPDM.

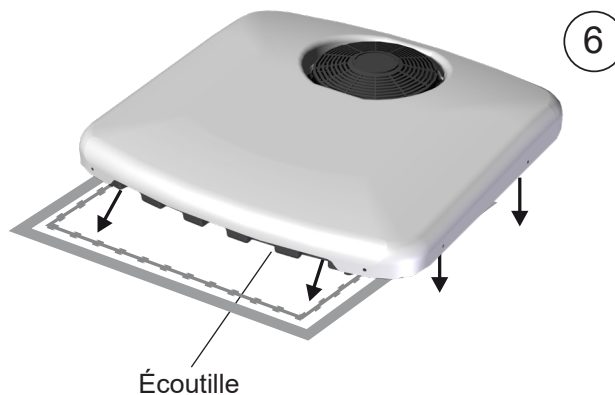

Écouille

- 7** Positionner les supports avec (4) vis 8/125x55, (4) rondelles plates Ø 8 larges et (4) rondelles grower Ø 8, en vissant les hexagones Ø 8.



- 8** Placer la console dans le panneau intérieur de distribution d'air et centrer l'équipement pour une position optimale de la console.

**Attention, une fois l'appareil centré, vérifier que la recirculation est bien dans l'espace de l'écouille, la base de l'appareil couvre tous les côtés du joint EPDM et les conduits d'évacuation sont à l'extérieur du joint EPDM!**



- 9** Serrer les vis de fixation jusqu'à ce que les supports butent avec les hexagones M8.

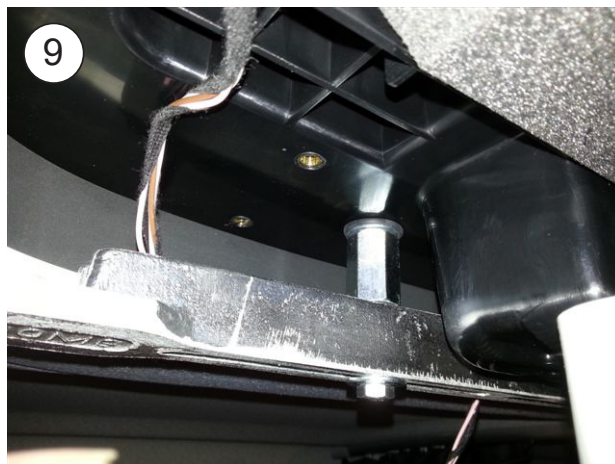

- 10** Fixer la console avec (4) vis 6/100x15 allen en vissant sur les hexagones M6 et inserts sur la base.

**Attention, retirer les câblages de lampes originales par les découpes de la console!**



- 11** Monter les lampes originales sur la console et placer (4) bouchons enjoliveurs pour cacher les vis M6 allen.

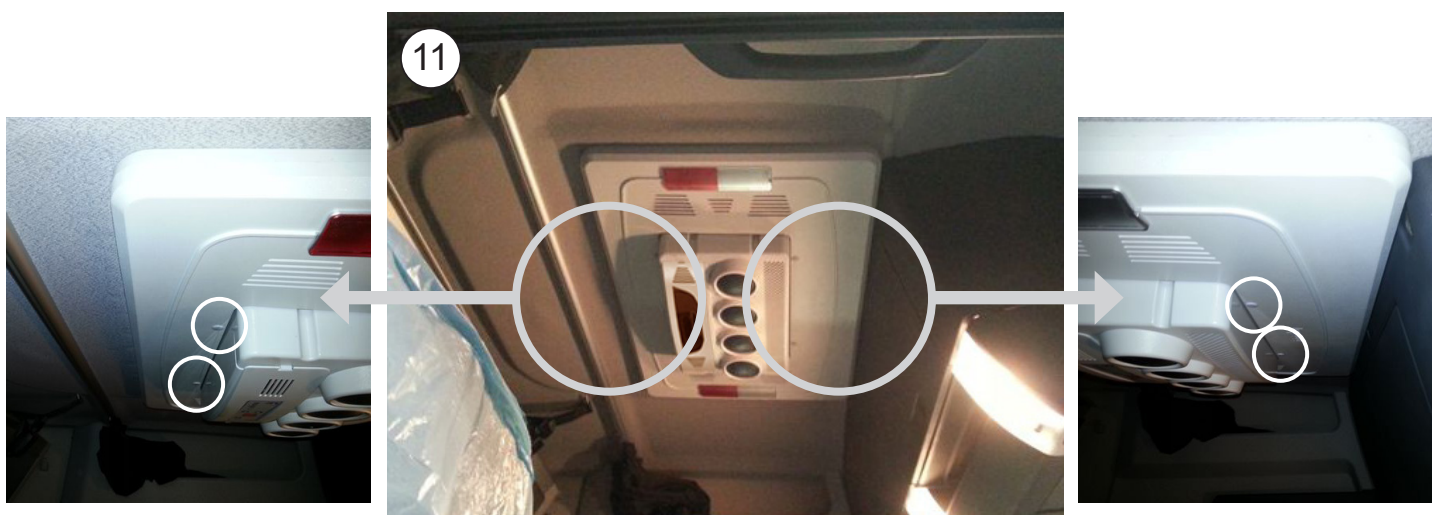



**Vue décomposée jusqu'à la fixation des supports**

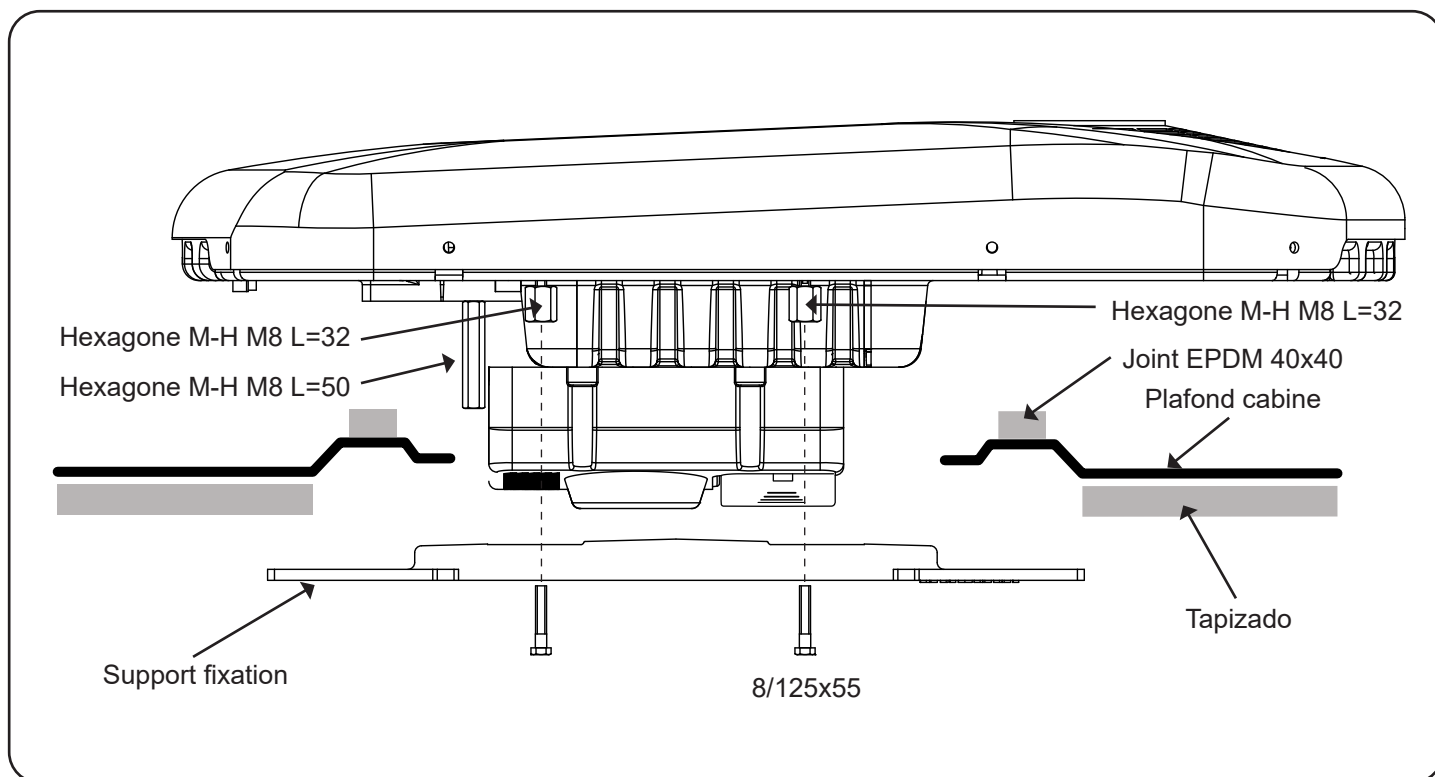

**Vue décomposée latérale jusqu'à la fixation des consoles**

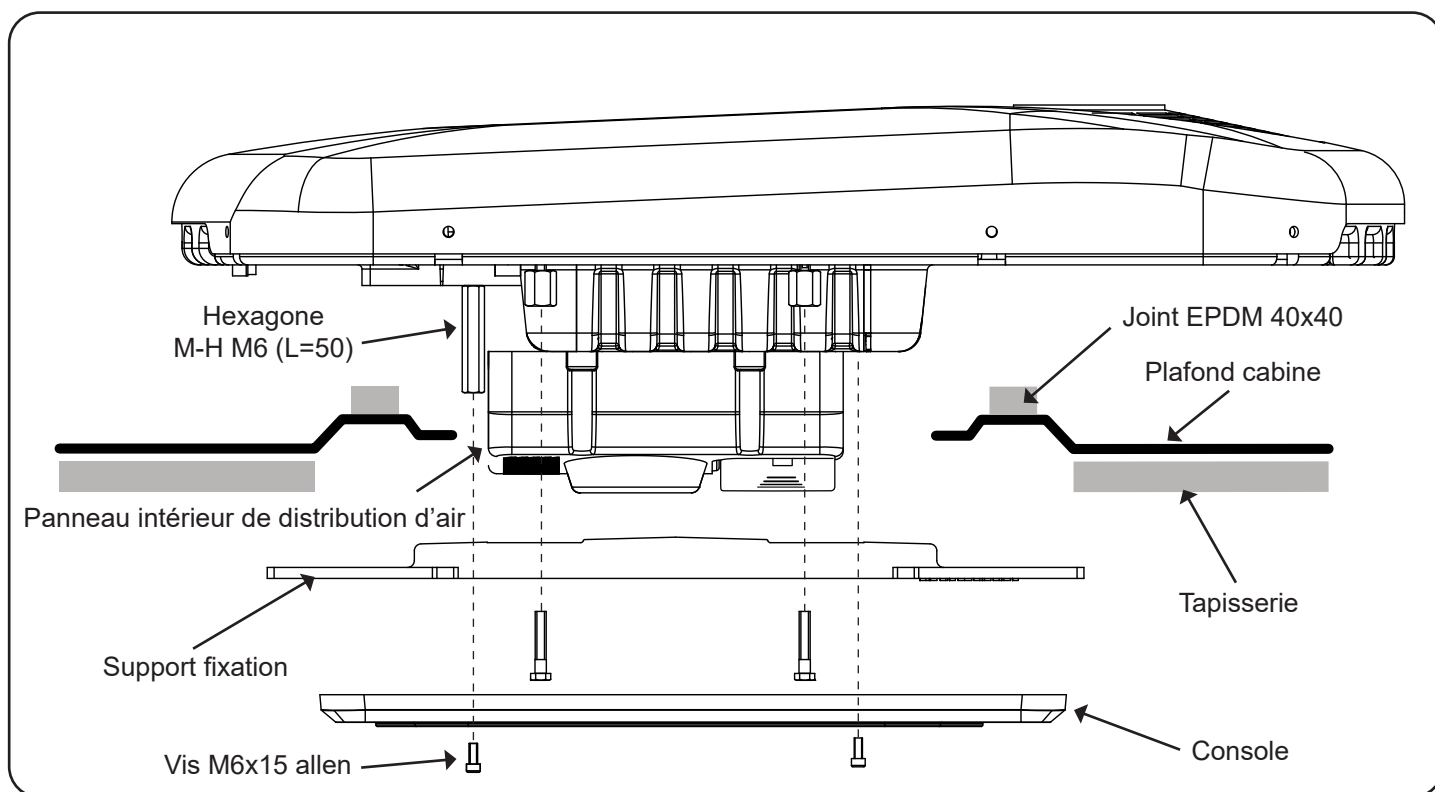

## Connexion du câblage de la batterie



**Remarque :** Selon le modèle de camion, il est possible de connecter l'équipement à plusieurs points de connexion.



**Attention :** Suivre les directives d'installation électrique conformément aux instructions du fabricant.

**A** Connexion dans la boîte à fusibles :

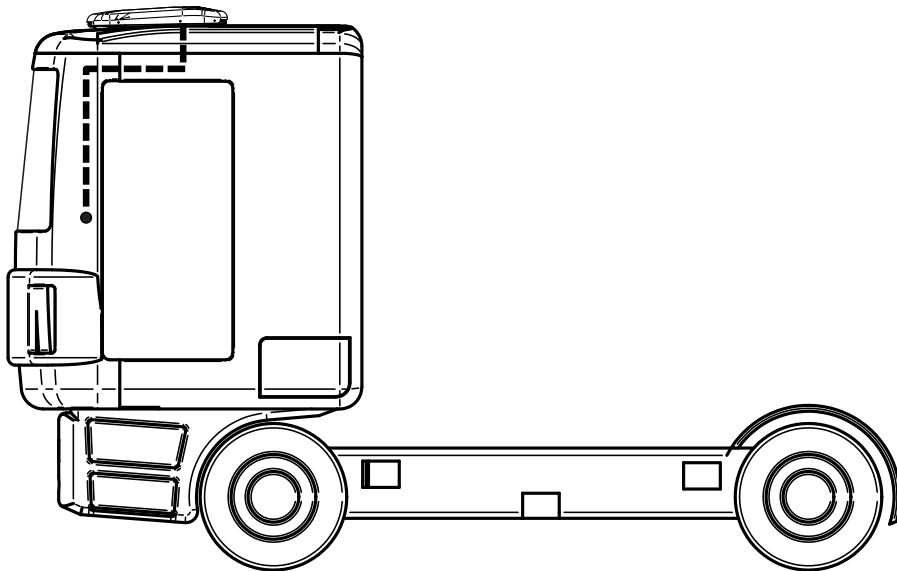

**B** Connexion à la batterie :

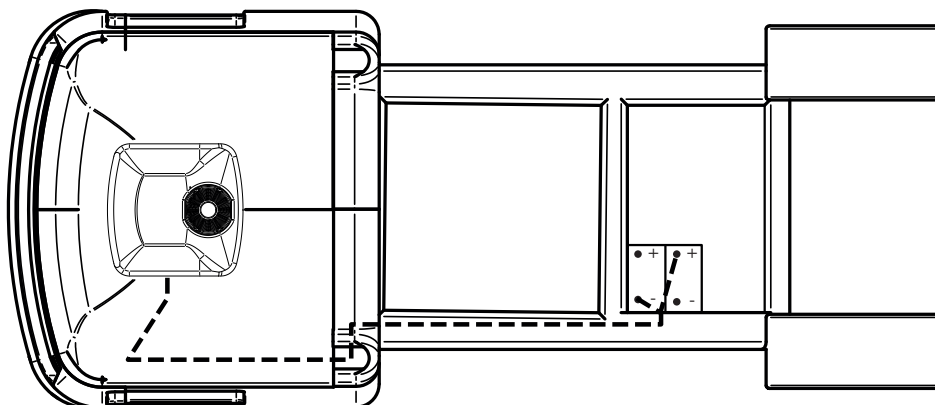

**C** Connexion dans la boîte de connexion de la grille avant :

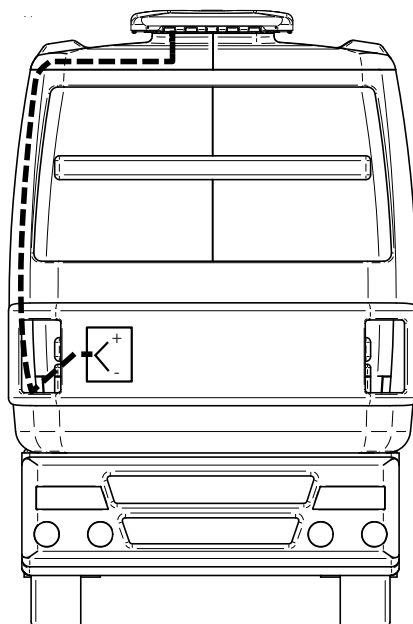

**Important: Pour la mise en marche, consulter le Manuel de l'Utilisateur.**

Schéma électrique

AVIS IMPORTANT !

**Attention** de ne pas inverser les polarités dans la connexion de l'alimentation à l'équipement. Si cela se produisait, la plaque ne s'allumerait pas et l'équipement ne fonctionnerait pas.

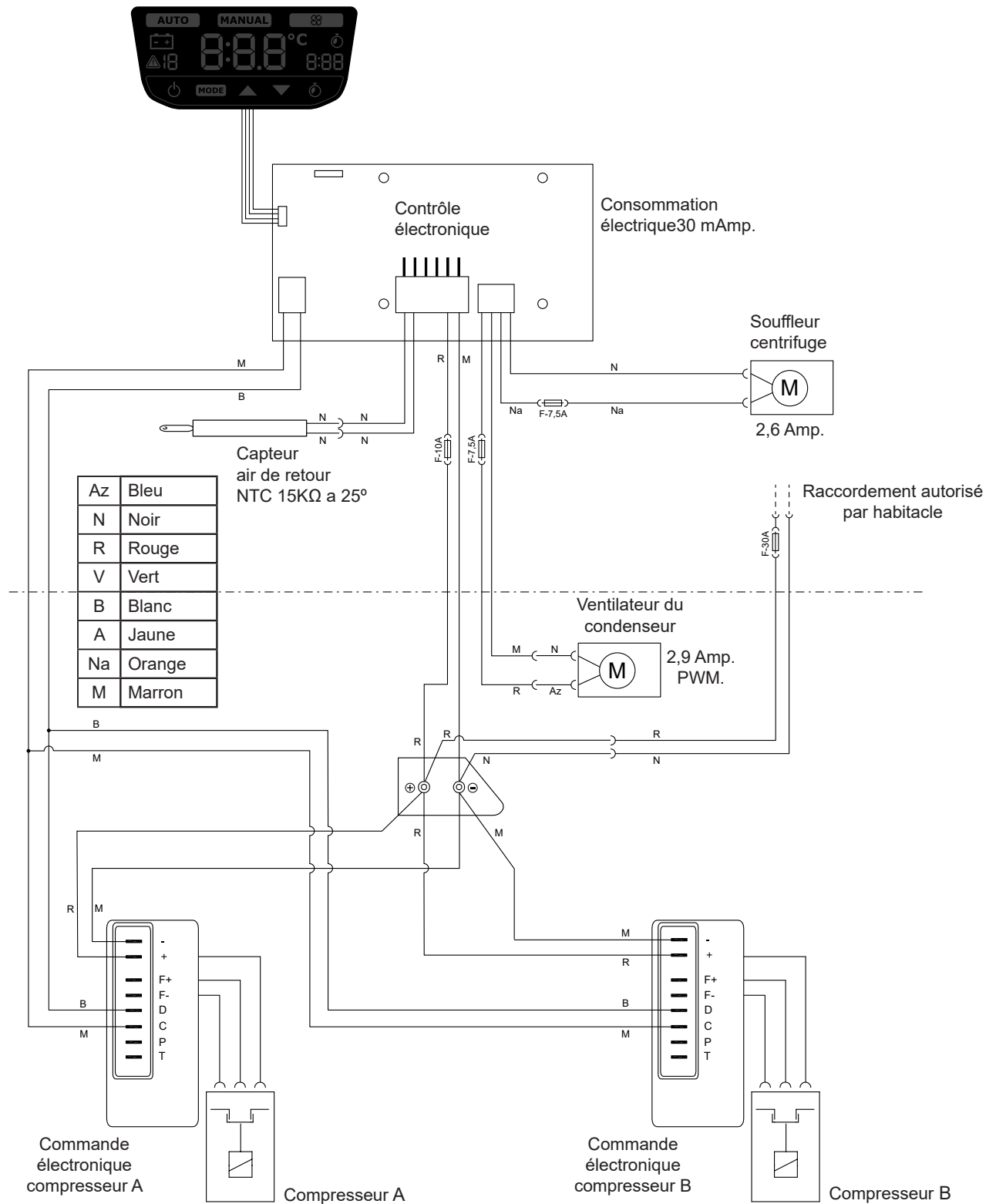



Wir danken Ihnen für Ihren Einkauf und Ihr Vertrauen in unsere Produkte. **SLIMFIT** ist eine von **Dirna Bergstrom** entwickelte und hergestellte Klimaanlage für den Einsatz in einem Kraftfahrzeug, dessen Motor während der Ruhezeiten im Schatten bzw. in der Nacht abgeschaltet ist.

**SLIMFIT** wurde mit der fortschrittlichsten Technik hergestellt, um eine effiziente Leistung sowie eine Reduzierung des Kraftstoffverbrauchs und der CO<sub>2</sub>-Emissionen in die Atmosphäre zu erreichen. Durch diese Eigenschaften ist diese Kfz-Klimaanlage einzigartig auf dem Markt.



**Bitte lesen Sie dieses Dokument vor der Installation des Produkts sorgfältig durch** und bewahren Sie es zum späteren Nachschlagen auf. Die Originaldokumentation wurde in spanischer Sprache verfasst; bei allen anderen Sprachen handelt es sich um Übersetzungen.

Alle Produkthanleitungen sind in digitaler Form unter <https://www.bergstromspain.com/> erhältlich.

Für alle Verkäufe und Garantievorgänge gelten unsere allgemeinen Geschäftsbedingungen in ihrer jeweils aktuellen Fassung, die auf unserer Website <https://www.bergstromspain.com/> veröffentlicht sind.

### Verwendete Symbole



- **Achtung:** Sicherheitshinweis, der auf eine Situation hinweist, die, wenn sie nicht vermieden wird, zum Tod oder zu schweren Verletzungen führen kann.



- **Gefahr:** Schnittgefahr. Weist auf eine Situation hin, die zu Schnittverletzungen führen kann.



- **Gefahr:** Stromschlaggefahr. Weist auf eine Situation hin, die zu einem Stromschlag führen kann.



- **Hinweis:** Sicherheitshinweis, der auf eine Situation hinweist, die, wenn sie nicht vermieden wird, zum Schäden am Gerät oder anderen Gegenständen führen kann.



- **Information:** Zusatzinformationen zu Installation oder Handhabung des Produkts.



- **Zerbrechlich:** Weist auf eine Situation hin, in der Vorsicht geboten ist, um Schäden am Gerät und anderen Gegenständen zu vermeiden.



### Haftung

- **Dirna Bergstrom** lehnt in den folgenden Fällen jede Haftung für Schäden ab:

- Beschädigung des Produkts durch mechanische Einflüsse und Überspannung.
- Änderungen am Gerät, die ohne ausdrückliche Genehmigung des Herstellers vorgenommen wurden.
- Verwendung des Geräts für Zwecke, die nicht in diesem Dokument beschrieben sind.
- Unsachgemäße Handhabung oder Installation des Geräts.

- Ohne ausdrückliche Genehmigung des Herstellers dürfen keine Eingriffe in die Kältemittelkreisläufe vorgenommen werden.



### Warnhinweise hinsichtlich der Montage

- Einbau, Reparatur und Wartung dieser Klimaanlage dürfen nur von Fachpersonal durchgeführt werden, das in Bezug auf Fahrzeugklimatisierung, mögliche Gefahren und geltende Normen ausreichend geschult ist.
- Bitte lesen Sie die Installationsanleitung sorgfältig durch, bevor Sie mit der Installation des Geräts beginnen. Befolgen Sie bei der Installation genau die hier gegebenen Anweisungen.
- Wird die Klimaanlage im Kabinendach installiert, muss der obere Teil der Kabine mit einem Tuch oder einer Decke gegen eventuelle Kratzer geschützt werden. Bei der Installation der **SLIMFIT** auf dem Kabinendach muss darauf geachtet werden, dass mit Luken ausgestattete Kabinen über eine ausreichend stabile Struktur verfügen, um das Gewicht des Geräts stand zu halten. Sollte das Fahrzeug über keine Luke verfügen und sollte es notwendig sein, das Kabinendach aufzuschneiden, bzw. sollte die vorhandene Struktur nicht ausreichend stabil sein (z.B. wenn sie aus Faser, Kunststoff usw. hergestellt ist), obliegt es dem Installateur zu entscheiden, ob das Kabinendach zur Vermeidung von Verformungen, Brüchen, undichten Stellen usw. verstärkt werden muss, und die hierfür notwendigen Mittel bereit zu stellen.
- Vor der Installation des Geräts den Zündschlüssel ausschalten.
- Vor der Installation des Geräts die Fahrzeugbatterie abklemmen.
- Die **SLIMFIT** sicher anbringen, damit sie nicht herunterfallen kann.

- Für jeden Arbeitsschritt geeignete Werkzeuge benutzen.
- Bei der Installation auf den Anschluss der elektrischen Komponenten achten und prüfen, ob diese richtig sitzen.
- Wenn die Kabel bei der Installation des Geräts entlang scharfkantiger Wände verlaufen, Leerrohre oder Führungen benutzen, um eine Beschädigung der Kabel zu vermeiden.
- Wird das Gerät während der Installation geneigt oder das Fahrerhaus mit montiertem Gerät gekippt, müssen ab dem Zeitpunkt, zu dem das Gerät wieder waagrecht liegt, mindestens 60 Minuten vergehen, bevor es in Betrieb genommen wird.
- Das Gerät ist mit Kältemittel R-134a vorgefüllt.



- **Wichtiger Hinweis:** Beim Anschluss des Geräts darauf achten, dass die Polarität nicht vertauscht wird, da sich sonst die Bedientafel nicht einschaltet und das Gerät nicht funktioniert.



#### Für die Montage erforderliche Werkzeuge

- Torx-Schraubenschlüssel
- Inbusschraubenschlüssel
- 10er, 13er, 14er Schraubenschlüssel
- Schere
- Metermaß



#### Bestimmungsgemäße Verwendung

- **SLIMFIT** ist eine auf dem Dach montierte Klimaanlage, die nur für den Einsatz in Lkw geeignet ist. Sie eignet sich nicht für den Einbau und Betrieb in landwirtschaftlichen Maschinen oder Baumaschinen, bei denen starke Schwingungen auftreten.
- Bei nicht bestimmungsgemäßer Verwendung erlischt die Garantie für das Gerät und die Haftung des Herstellers ist ausgeschlossen.
- Wenn Sie hinsichtlich der Verwendung der **SLIMFIT** unsicher sind, schlagen Sie bitte in der Bedienungsanleitung des Produkts nach.
- Wenn die Temperatur im Fahrerhaus Ihres Fahrzeugs zum Ausruhen zu hoch ist, kühlen Sie das Fahrerhaus zunächst einige Minuten lang mit der Klimaanlage Ihres Fahrzeugs ab und lassen Sie dann die **SLIMFIT** laufen, um die Komforttemperatur zu halten.



#### Zugehörige Dokumente

- Kurzanleitung: 1003115344
- Bedienungsanleitung: 1003148646
- Ersatzteilliste: 1003345642
- Fehlerbehebung: 1003148649

**Dirna Bergstrom** erklärt, dass das Gerät **SLIMFIT** den Anforderungen der folgenden EG-Richtlinien entspricht und dass die unten aufgeführten harmonisierten Normen und technischen Spezifikationen angewendet wurden:

- Richtlinie 2014/53/EU
- Richtlinie 2011/65/EU
- Richtlinie 2014/30/EU



An Fahrzeugen TGX Kabine XLX mit Spoiler kann das Gerät nicht installiert werden.

An Fahrzeugen mit Spoiler (\*) müssen die durchzuführenden Änderungen vom Kunden genehmigt werden. Deshalb haftet dirna Bergstrom nicht für den Umbau des Spoilers. Sind die erforderlichen Umbauten am Spoiler genehmigt, muss dieser vor der Installation ausgebaut werden.



**1** Spoiler ausbauen. Lukendeckel und Befestigungsteile abnehmen und dem Kunden übergeben.



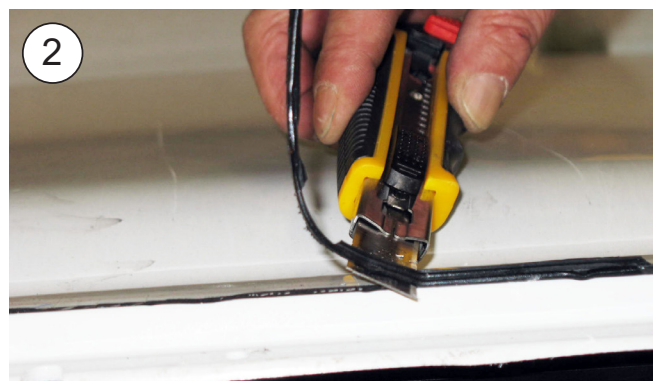

**2** An der Decke haftende Reste entfernen, bevor die EPDM-Dichtung eingeklebt wird.



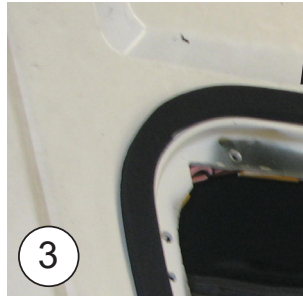

**3** Kleben Sie die EPDM-Dichtung 40x40 um den Steg der Lukenöffnung. (Beachten Sie die Detailbeschreibung zum Beschneiden der Endverbindungskanten der Dichtung).



 **WIE BESCHNEIDET MAN DIE EPDM-DICHTUNG, UM DAS EINSICKERN VON WASSER ZU UNTERBINDEN**

**A-** Dichtung einkleben und 100 mm des Schutzpapiers an jeder Seite überstehen lassen.

**B-** Die beiden Papierstücke entfernen

**C-** Kleben Sie die Dichtung ein, indem Sie beide Enden andrücken.

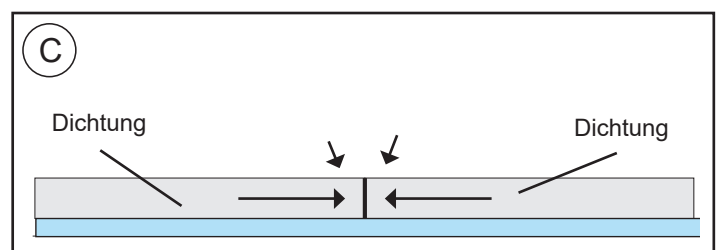
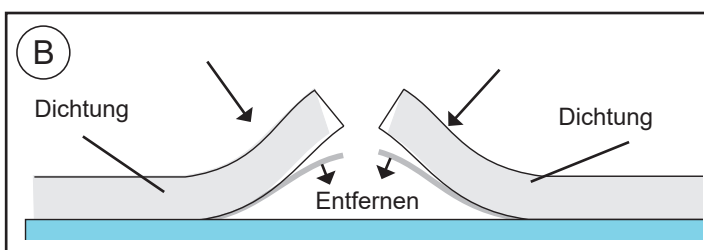
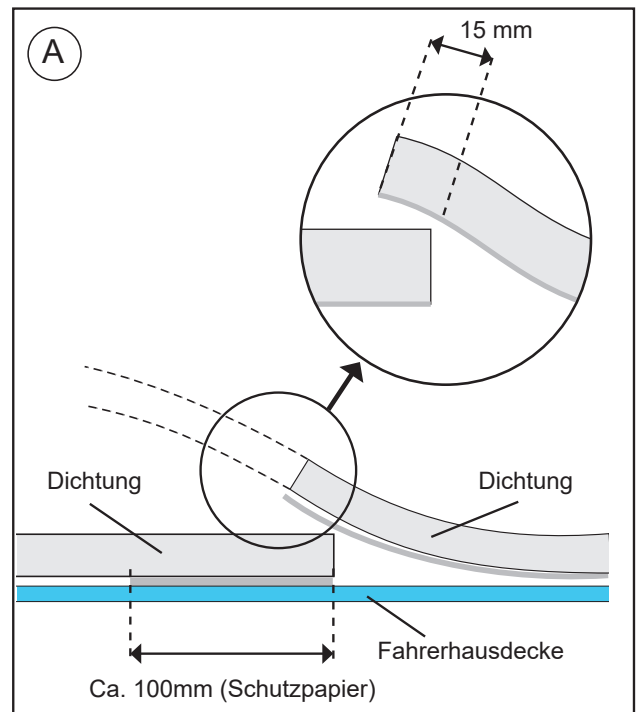

**4** (4) Sechskantschrauben M8 L=32 mit Gummiauferlegscheibe Ø 20 und Flachscheibe Ø 8 in die Einsätze der Grundplatte schrauben und anziehen.

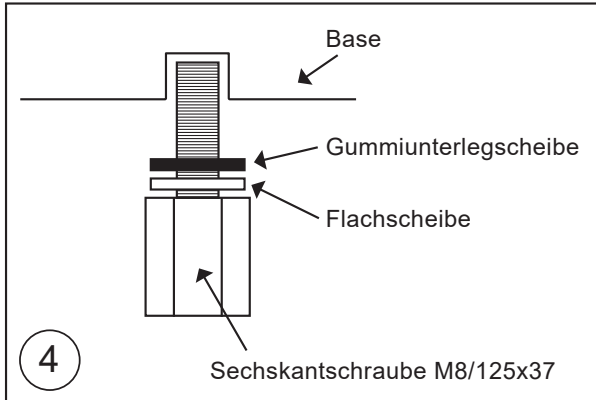

**5** (2) Sechskantschrauben M6/100x50 mit Gummiauferlegscheibe Ø 18 und Breitflansch-Flachscheibe Ø 6 in die vorderen Einsätze der Grundplatte schrauben und anziehen.

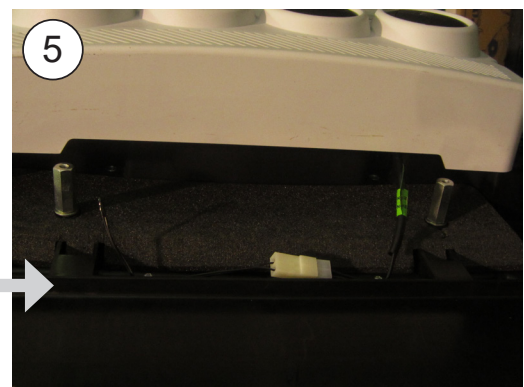
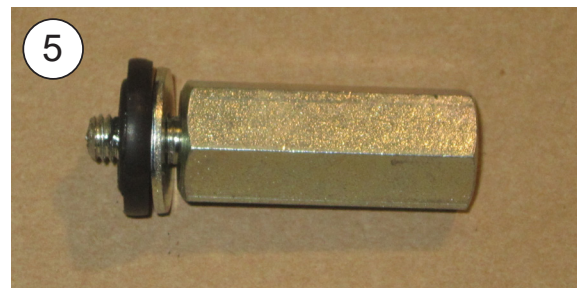

- 6** **KABINENAUSSENSEITE:**  
**SLIMFIT** in der Lukenaussparung auf der EPDM-Dichtung positionieren.

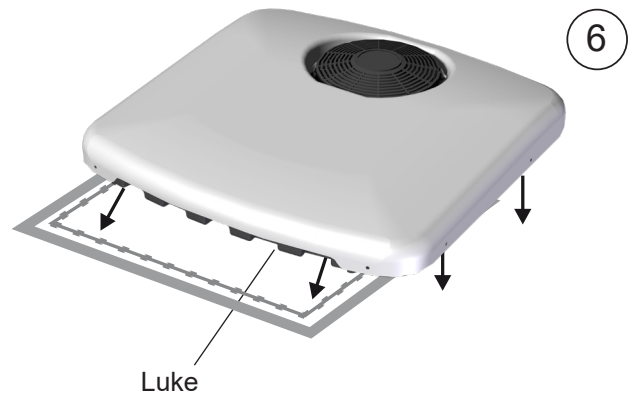

- 7** Halterungen mit (4) Schrauben 8/125x55, (4) Breitflansch-Flachscheiben  $\varnothing$  8 und (4) Grower-Scheiben  $\varnothing$  8 positionieren und in Sechskant-Verbindungs-muttern  $\varnothing$  8 einschrauben.



- 8** Konsole an der inneren Luftverteiltertafel positionieren und Gerät an geeigneter Stelle zentrieren.  
**Achtung! Nach dem Zentrieren des Geräts prüfen, ob die Rückführung sich innerhalb der Lukenaussparung befindet, die Gerätegrundplatte die EPDM-Dichtung an allen Stellen abdeckt und die Ablässe sich außerhalb der EPDM-Dichtung befinden!**



- 9** Befestigungsschrauben anziehen, bis die Halterungen an die Sechskant-Verbindungs-muttern M8 anschlagen.



**10** Konsole mit (4) Innensechskantschrauben 6/100x15, die in die Sechskant-Verbindungs-muttern M6 und die Einsätze der Grundplatte geschraubt werden, fixieren.

**Achtung! Kabel der Originallichter durch die für die Konsole ausgeschnittene Stelle herausziehen!**



**11** Originallichter an der Konsole montieren und die Innensechskantschrauben M6 mit (4) Zierkappen abdecken.



Explosionsansicht bis zur Befestigung der Auflagen

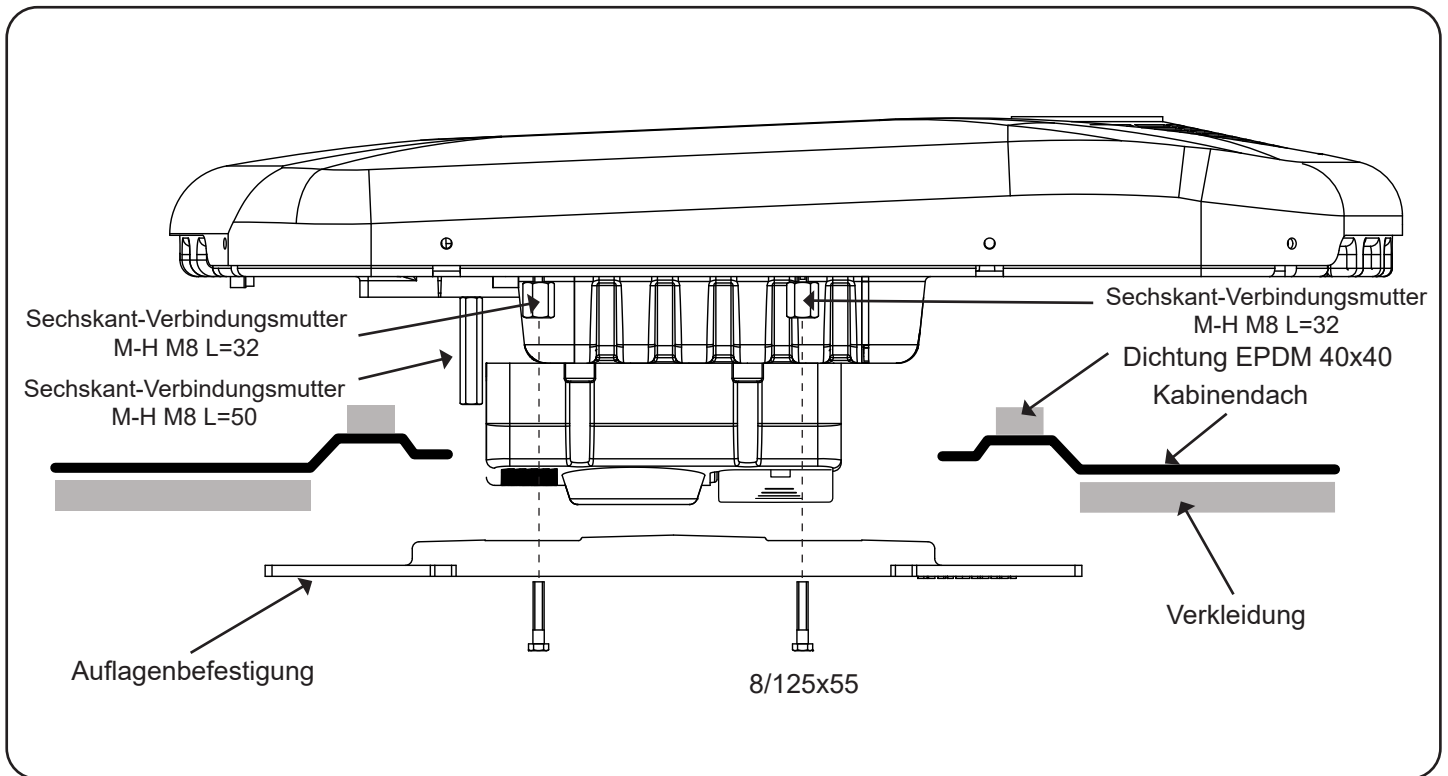

Explosionsseitenansicht bis zur Befestigung der Konsolen

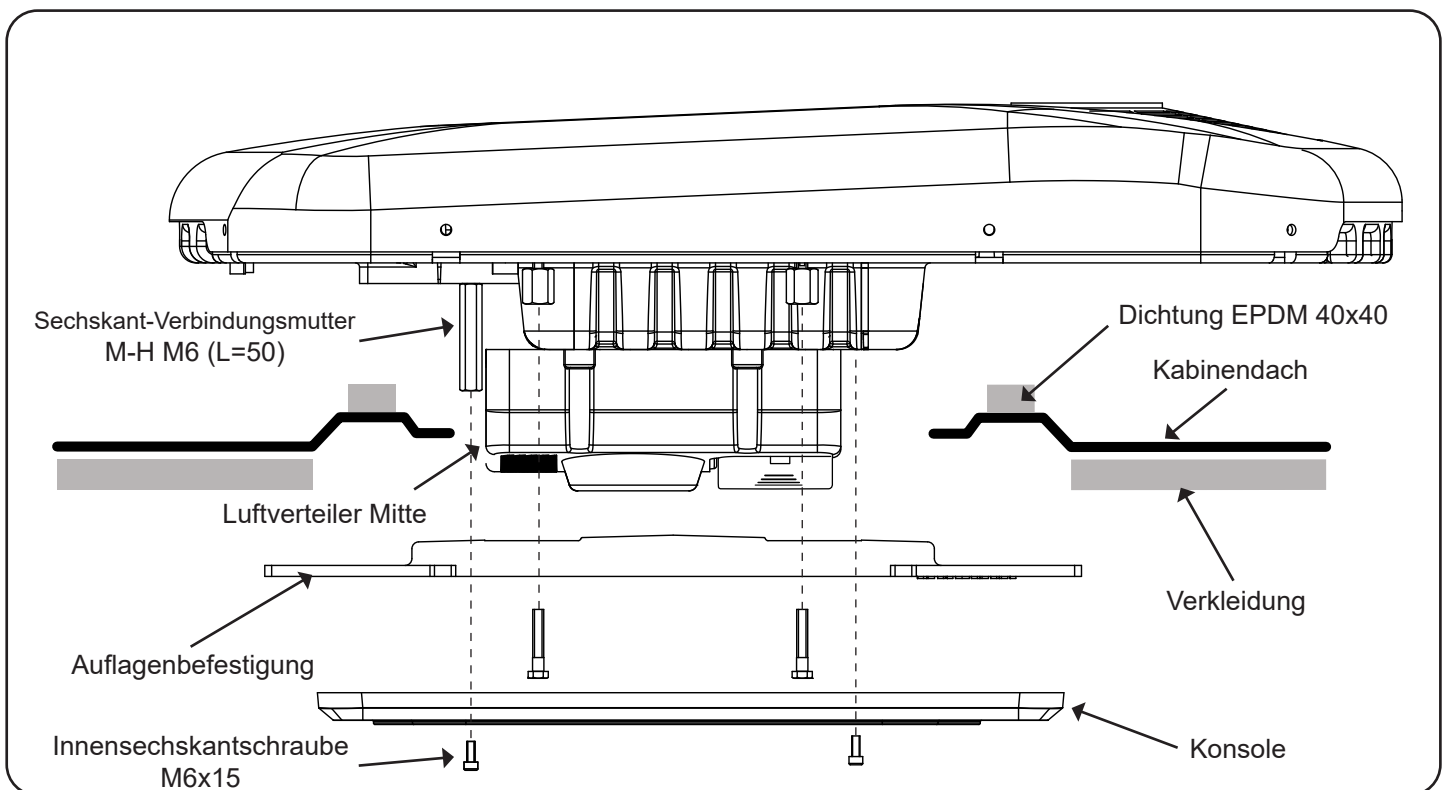

## Anschluss batterie kabel



**Hinweis:** Ja nach Lkw-Modell kann das Gerät an verschiedenen Stellen angeschlossen werden.



**Achtung:** Herstellerhinweise bezüglich der elektrischen Installation beachten.

**A**

Anschluss am Sicherungskasten:

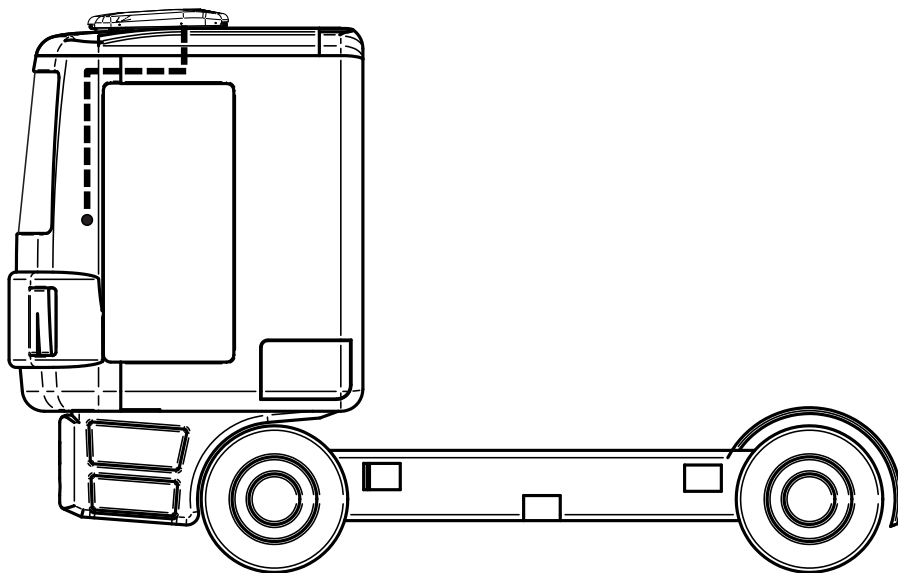

**B**

Anschluss an den Batterien:

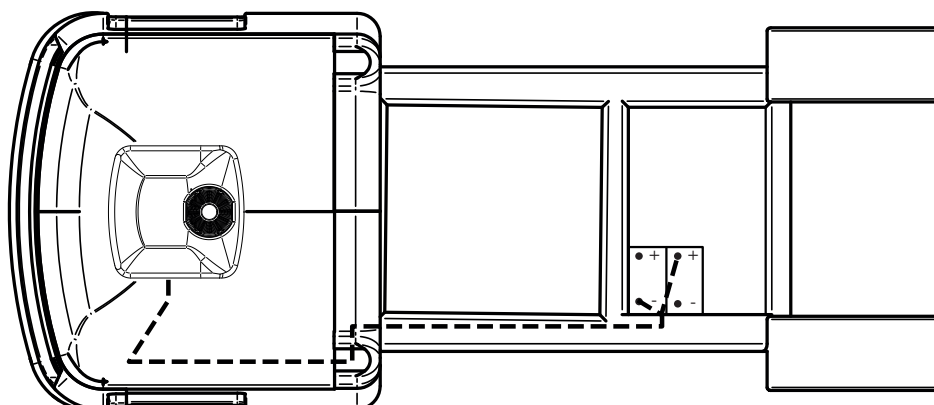

**C** Anschluss am Anschlusskasten vorderer Kühlergrill:

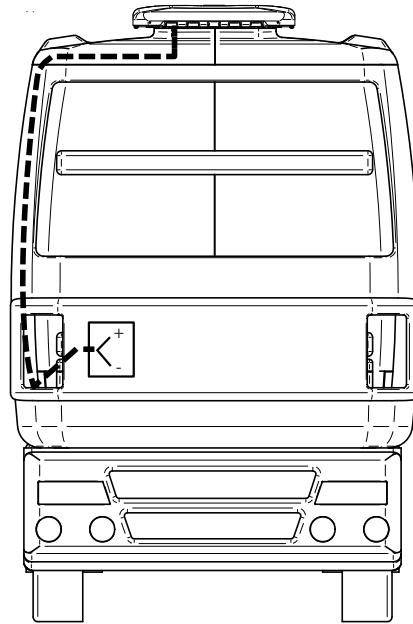

**Wichtig: Für die Inbetriebnahme lesen Sie Bitte genau die Vorschriften im Benutzerhandbuch.**

Elektrische Verkabelung

WICHTIGER HINWEIS!

**Achtung!** Die Polaritäten beim Anschluss der Anlage an die Batterie nicht vertauschen. Ist dies der Fall, schaltet sich die Bedientafel nicht ein und das Gerät funktioniert nicht.

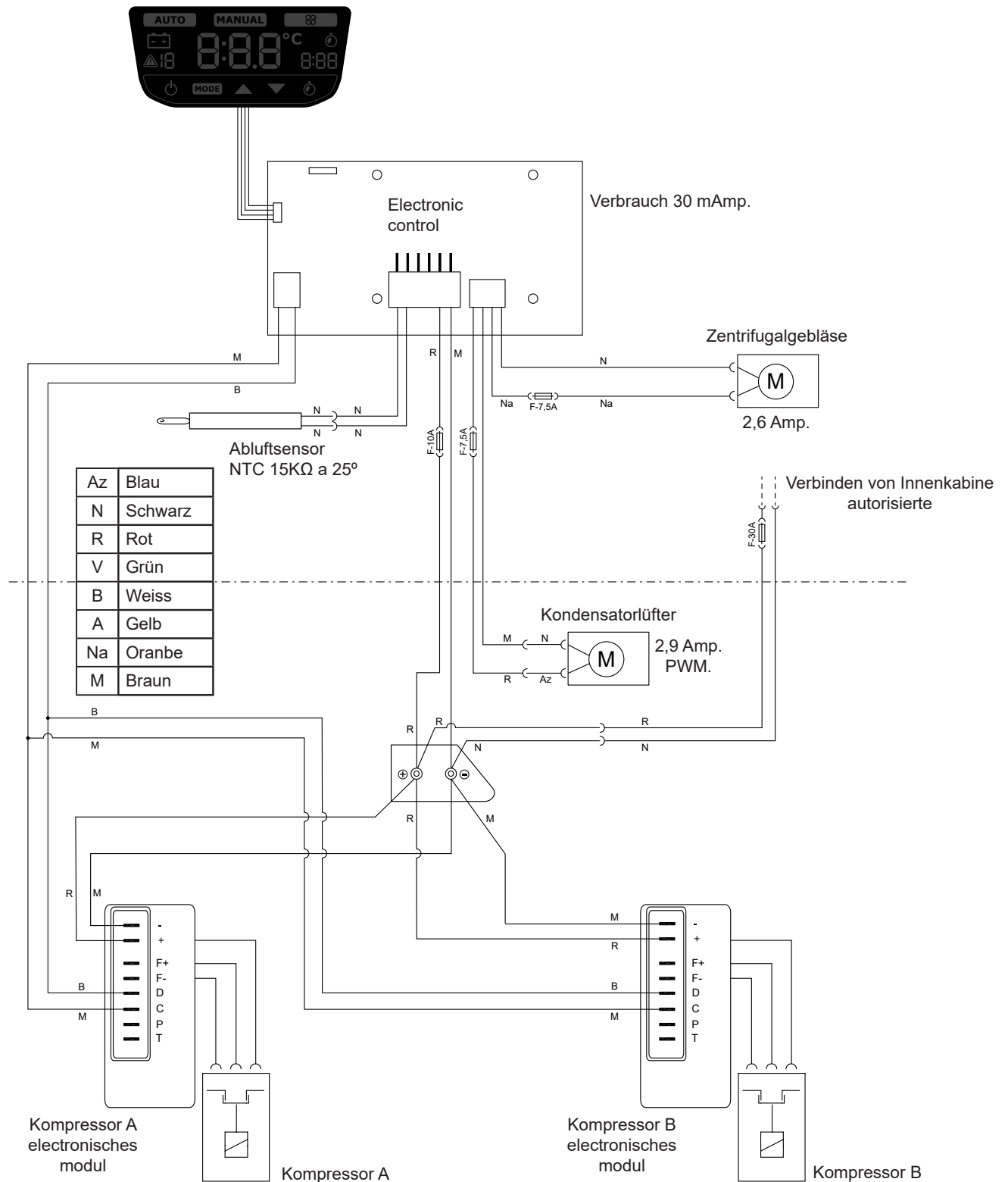



A series of horizontal dotted lines spanning the width of the page, intended for handwritten notes or calculations.

Grazie per l'acquisto e per la fiducia riposta nella nostra gamma di prodotti. **SLIMFIT** è un impianto di aria condizionata progettato e prodotto da **Dirna Bergstrom** per essere usato con il motore del veicolo fermo durante i periodi di sosta all'ombra e/o di notte.

**SLIMFIT** è progettato con la tecnologia più avanzata per ottenere ottime performance e ridurre i consumi di combustibile e le emissioni di CO<sub>2</sub> in atmosfera. Proprio grazie a queste caratteristiche, è unico nel mercato dell'aria condizionata per veicoli.



**Leggere attentamente questo documento prima di installare il prodotto.** Conservare questo documento con cura per poterlo consultare in futuro. La documentazione originale è stata stilata in spagnolo, perciò le altre lingue sono traduzioni.

Tutti i manuali del prodotto sono disponibili in versione digitale (PDF) su <https://www.bergstromspain.com/>

La vendita e la garanzia sono disciplinate dalla versione più aggiornata delle nostre condizioni generali di vendita, pubblicata sul nostro sito web <https://www.bergstromspain.com/>

### Spiegazione dei simboli



- **Avvertenza:** Avvertenza di sicurezza riguardo a una situazione che, se non venisse evitata, potrebbe provocare gravi lesioni anche mortali.



- **Pericolo:** Rischio di taglio. Segnala una situazione che potrebbe provocare una lesione da taglio.



- **Pericolo:** Rischio di folgorazione. Segnala una situazione che potrebbe provocare una lesione da folgorazione.



- **Avviso:** Avviso di sicurezza riguardo a una situazione che, se non venisse evitata, potrebbe provocare danni all'impianto o ad altri materiali.



- **Informazioni:** Ulteriori informazioni sull'installazione o sulla gestione del prodotto.



- **Fragile:** Indica una situazione in cui si deve procedere con attenzione per non causare danni all'impianto e ad altri materiali.



### Esclusione di responsabilità

- **Dirna Bergstrom** declina ogni responsabilità per eventuali danni causati dai casi seguenti:

- Danni al prodotto provocati da sollecitazioni meccaniche e sovratensioni.
- Modifiche effettuate sull'impianto senza esplicita autorizzazione del costruttore.
- Uso l'impianto per fini diversi da quelli riportati in questo documento.
- Movimentazione o installazione errata dell'impianto.

- È vietato qualsiasi intervento sui circuiti del gas refrigerante senza esplicita autorizzazione del costruttore.



### Avvertenze durante il montaggio

- L'installazione, la riparazione e la manutenzione di questo impianto di aria condizionata possono essere eseguite esclusivamente da personale tecnico in possesso della formazione necessaria nel campo dell'aria condizionata per veicoli, eventuali pericoli e norme applicabili.

- Leggere attentamente le istruzioni di montaggio prima di iniziare l'installazione dell'impianto. Durante l'installazione, seguire alla lettera le istruzioni indicate.

- Quando si installa l'impianto di aria condizionata sul tettuccio, bisogna proteggere la parte superiore della cabina con uno straccio o una coperta per evitare eventuali graffi. Per l'installazione del **SLIMFIT**, tenere presente che normalmente le cabine munite di oblò dispongono di una struttura abbastanza solida per sostenere il peso dell'impianto. Tuttavia, se così non fosse e se fosse necessario tagliare il tettuccio, o se in presenza di oblò la struttura non fosse abbastanza rigida (se fosse di fibra, plastica, ecc.), è responsabilità dell'installatore decidere se occorre rinforzare il tettuccio per evitare qualsiasi deformazione, rottura o penetrazione d'acqua, ecc., prendendo le misure necessarie per evitarlo.

- Disinserire la chiave di avviamento prima di iniziare l'installazione dell'impianto.

- Disinserire la batteria del veicolo prima di cominciare l'installazione dell'impianto.

- Installare **SLIMFIT** in modo sicuro per evitare cadute.

- Usare gli attrezzi più adatti per ogni operazione.
- Durante l'installazione, assicurare la connessione dei componenti elettrici, verificandone il corretto inserimento.
- Se nell'installazione dell'impianto i cablaggi attraversano pareti con bordi affilati, proteggere adeguatamente i cavi con guaine o passacavi per evitarne il danneggiamento.
- Se durante l'installazione l'impianto viene inclinato o si ribalta la cabina con l'impianto installato, prima di avviarlo occorre attendere almeno 60 minuti dal momento in cui l'impianto è di nuovo in posizione orizzontale.
- Dispositivo precaricato con gas refrigerante R-134a.



- **Avvertenza importante:** quando si collega l'impianto, fare attenzione a non invertire le polarità. Se ciò dovesse succedere, il quadro comandi non si accende e l'impianto non si avvia.



#### Attrezzi necessari per il montaggio

- Kit di chiavi Torx.
- Kit di chiavi Allen.
- Chiave fissa 10, 13, 14.
- Forbici.
- Metro a nastro.
- Cacciavite.



#### Corretto uso del prodotto

- **SLIMFIT** è un impianto di aria condizionata da installare sul tetto ed è destinato esclusivamente ai camion. Non è adatto a macchinari agricoli, né per l'edilizia soggetti a forti vibrazioni.
- L'uso non conforme a quello previsto comporta l'annullamento della garanzia dell'impianto e l'esclusione di responsabilità da parte del costruttore.
- In caso di incertezze riguardo all'uso di **SLIMFIT**, consultare il manuale dell'utente del prodotto.
- Se la temperatura nella cabina del veicolo è molto elevata per un riposo confortevole, raffreddare la cabina con l'aria condizionata del veicolo per qualche minuto e quindi avviare **SLIMFIT** per mantenere la temperatura di comfort.



#### Documenti correlati

- Guida rapida: 1003115344
- Manuale dell'utente: 1003148646
- Elenco dei pezzi di ricambio: 1003345642
- Diagnosi dei guasti: 1003148649

**Dirna Bergstrom** dichiara che l'impianto **SLIMFIT** soddisfa i requisiti delle seguenti direttive CE e che sono state applicate le norme e le specifiche tecniche armonizzate riportate di seguito:

- Direttiva CE 2014/53/EU
- Direttiva CE 2011/65/EU
- Direttiva CE 2014/30/EU



Nei veicoli TGX cabina XLX con spoiler, non è possibile installare l'impianto.

Nei veicoli con spoiler (\*) le modifiche da eseguire sullo stesso devono essere autorizzate dal cliente, perciò d'ora in poi Bergstrom declina ogni responsabilità per quanto riguarda la modifica dello spoiler. In caso di autorizzazione delle modifiche da eseguire sullo spoiler, occorre smontare quest'ultimo prima di cominciare l'installazione.



- 1** Smontare lo spoiler. Smontare il coperchio del tettuccio apribile, gli elementi di fissaggio e consegnarli al cliente.



- 2** Rimuovere i residui eventualmente rimasti attaccati al tetto prima di incollare la guarnizione EPDM.

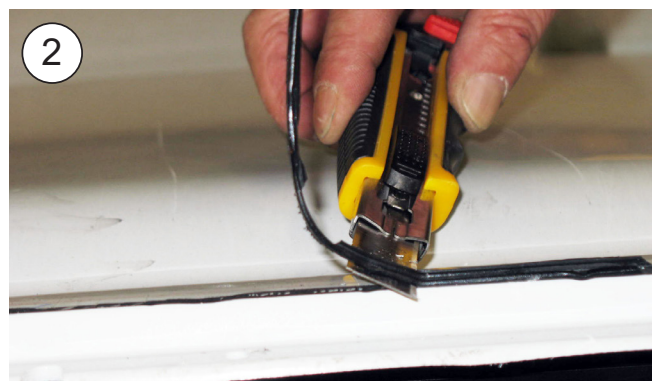

- 3** Incollare la guarnizione EPDM 40x40 intorno alla sporgenza del vano del tettuccio apribile (vedi il particolare per tagliare i bordi finali di unione della guarnizione).

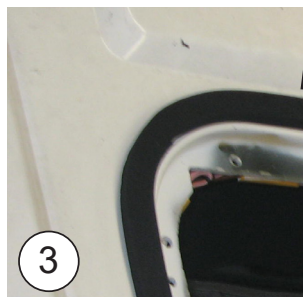

**COME TAGLIARE LA GUARNIZIONE EPDM PER EVITARE L'INFILTRAZIONE DELL'ACQUA NELLA CABINA**

- A-** Incollare la guarnizione, lasciando 100 mm di carta protettiva su ogni lato.
- B-** Rimuovere i due pezzi di carta.
- C-** Incollare premendo entrambe le estremità.

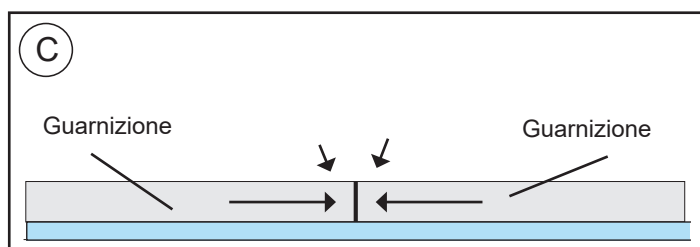
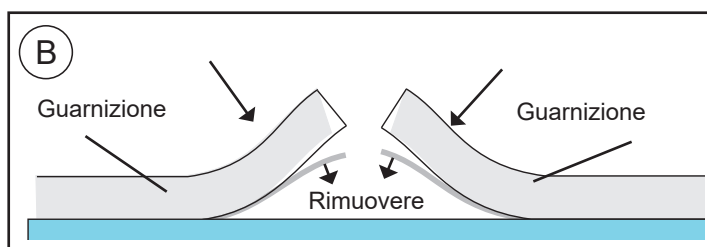
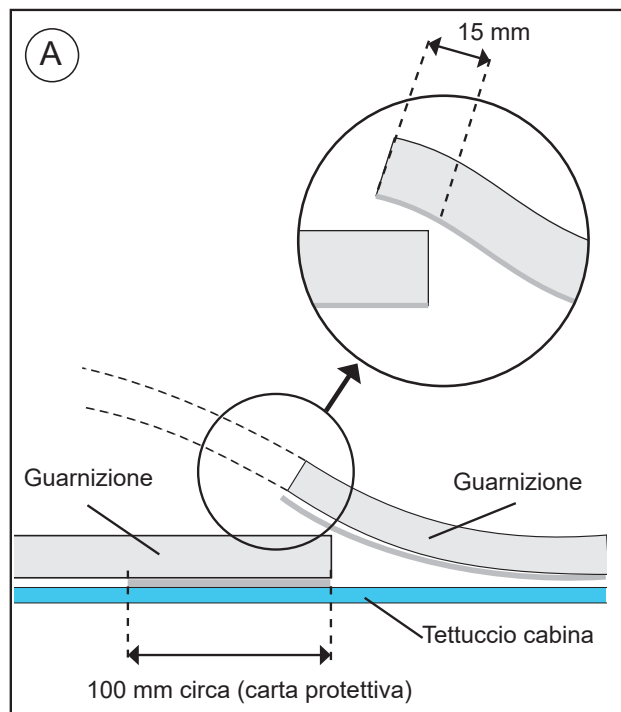

**4** Avvitare (4) perni esagonali M8 L=32 con rondella di gomma  $\varnothing 20$ , rondella piana  $\varnothing 8$  negli inserti della base e stringere.

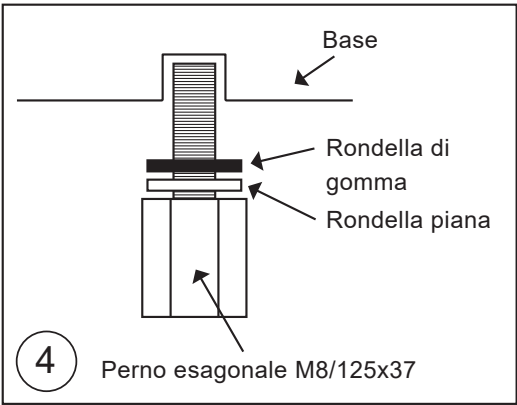
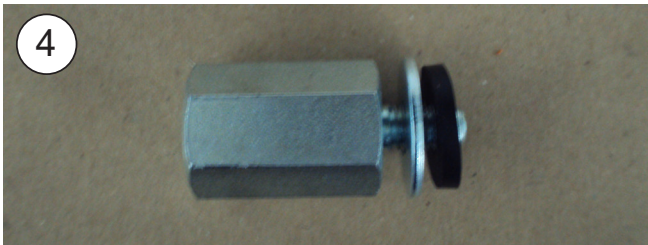

**5** Avvitare (2) perni esagonali M6/100x50 con rondella di gomma  $\varnothing 18$ , rondella piana  $\varnothing 6$  a testa larga negli inserti della base e stringere.

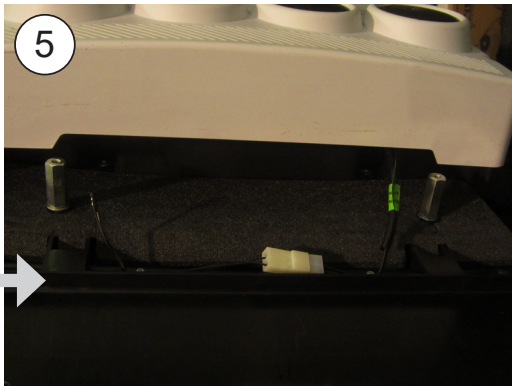

**6 ESTERNO CABINA:**

Inserire lo **SLIMFIT** nel vano del tettuccio apribile sulla guarnizione in EPDM.



- 7** Fissare i supporti con (4) viti 8/125x55, (4) rondelle piane Ø 8 a testa larga e (4) rondelle grower Ø 8, avvitando sui perni esagonali Ø 8.



- 8** Collocare la console nel pannello interno di distribuzione dell'aria e centrare l'impianto per sistemare adeguatamente la console.

**Attenzione! Una volta centrato l'impianto, verificare che il ricircolo sia all'interno del vano del tettuccio, che la base dell'impianto copra su tutti i lati la guarnizione in EPDM e che gli scarichi siano all'esterno della guarnizione in EPDM.**



- 9** Stringere le viti di fissaggio finché i supporti non sono a battuta con i perni esagonali M8.

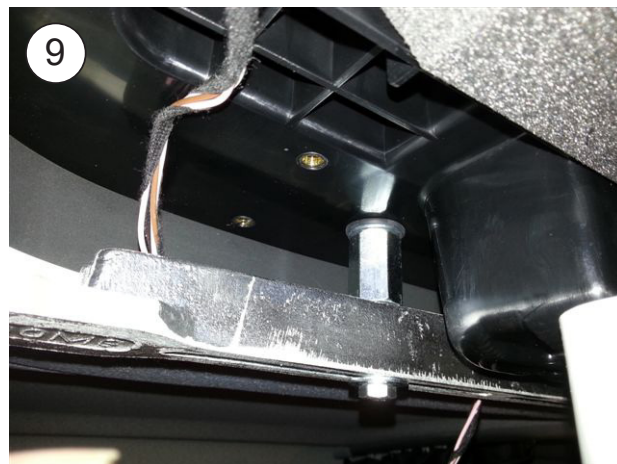

- 10** Fissare la console con (4) viti a brugola 6/100x15 avvitando sui perni esagonali M6 e gli inserti sulla base.

**Attenzione! Estrarre i cablaggi delle luci originali dalle aperture sulla console.**



- 11** Montare le luci originali sulla console e inserire (4) tappini decorativi sulle viti M6 a brugola.





### Esploso fino al fissaggio dei supporti

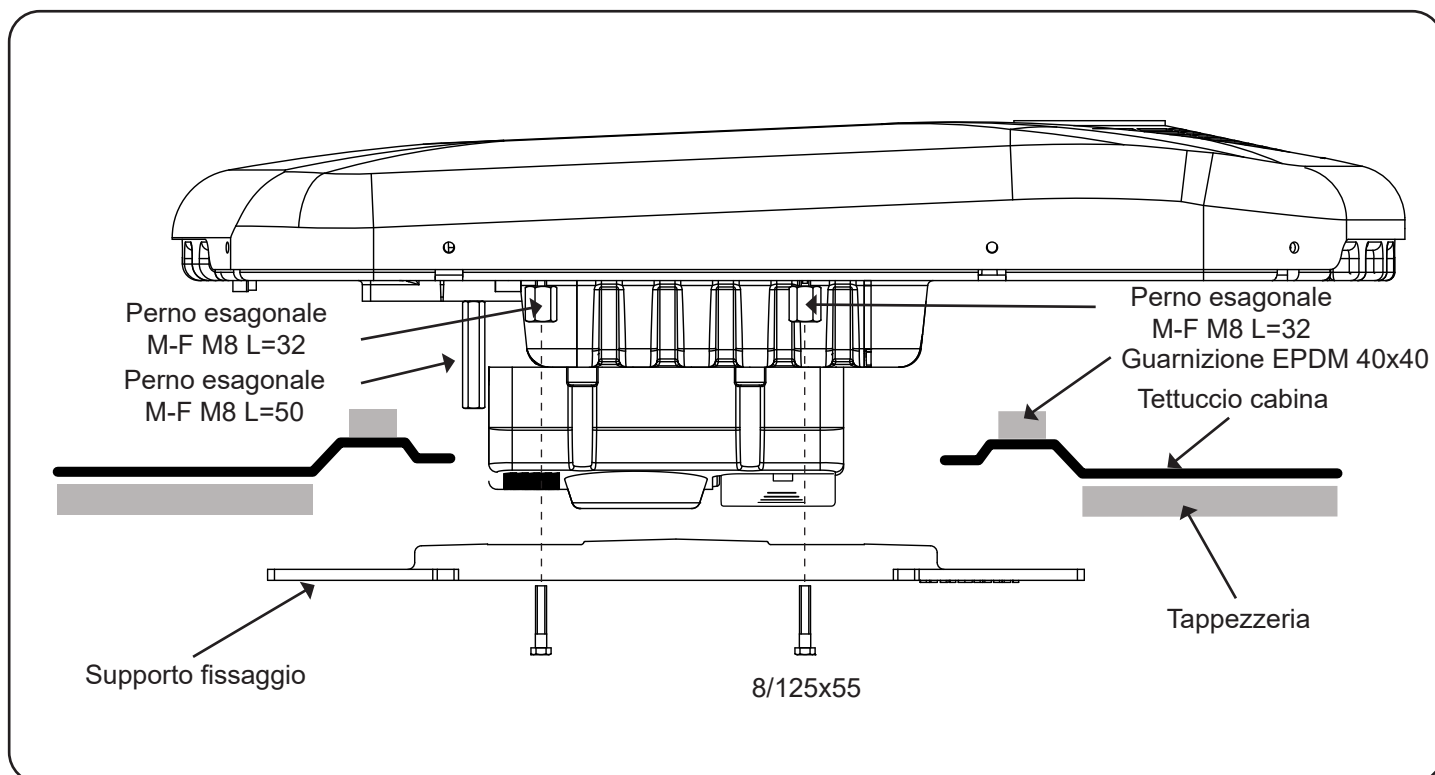

### Esploso visto di lato fino al fissaggio delle console

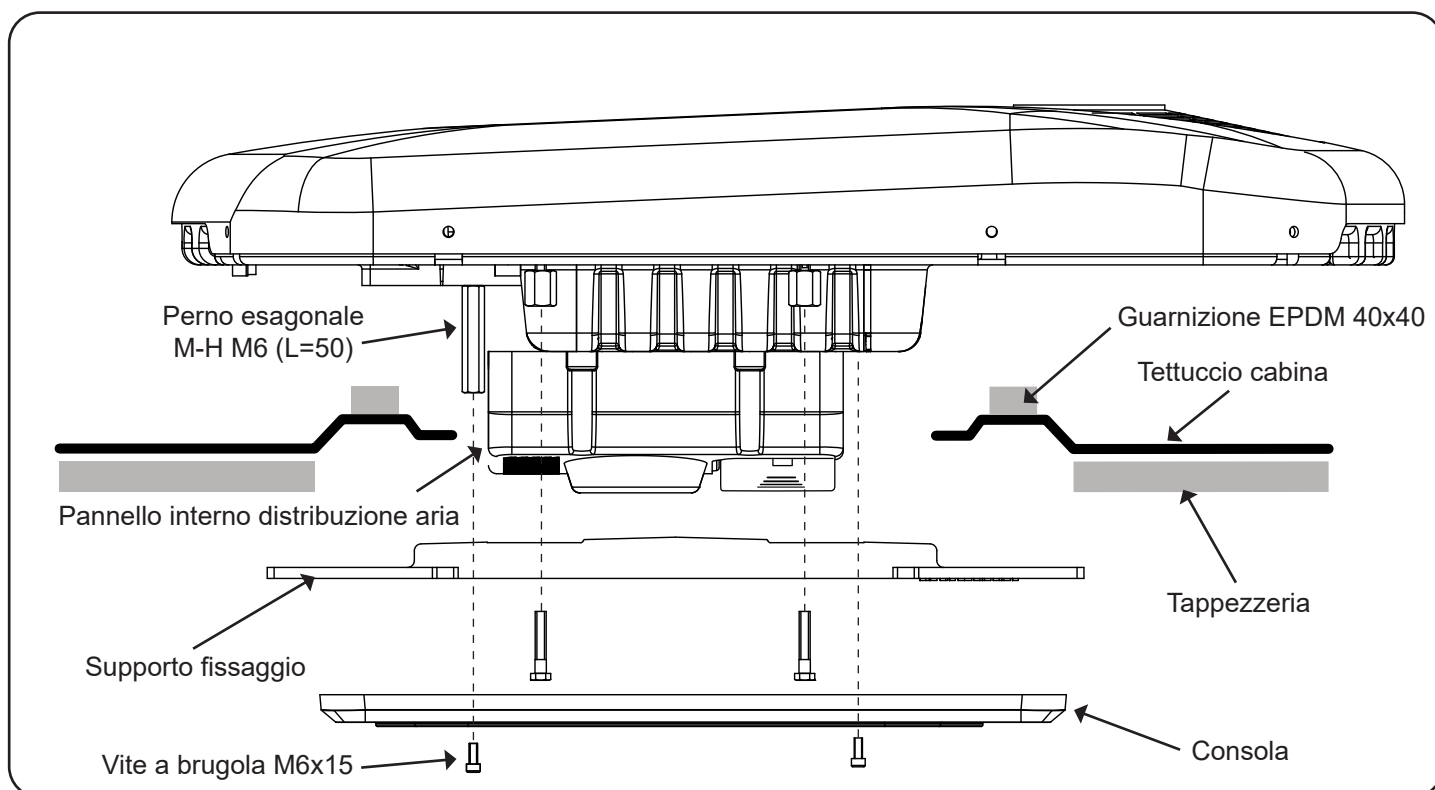

## Collegamento del cablaggio della batteria



**Nota:** a seconda del modello di carrello, è possibile collegare l'apparecchiatura a più punti di connessione.



**Attenzione:** seguire le linee guida per l'installazione elettrica secondo le istruzioni del produttore.

**A** Collegamento nella scatola dei fusibili:

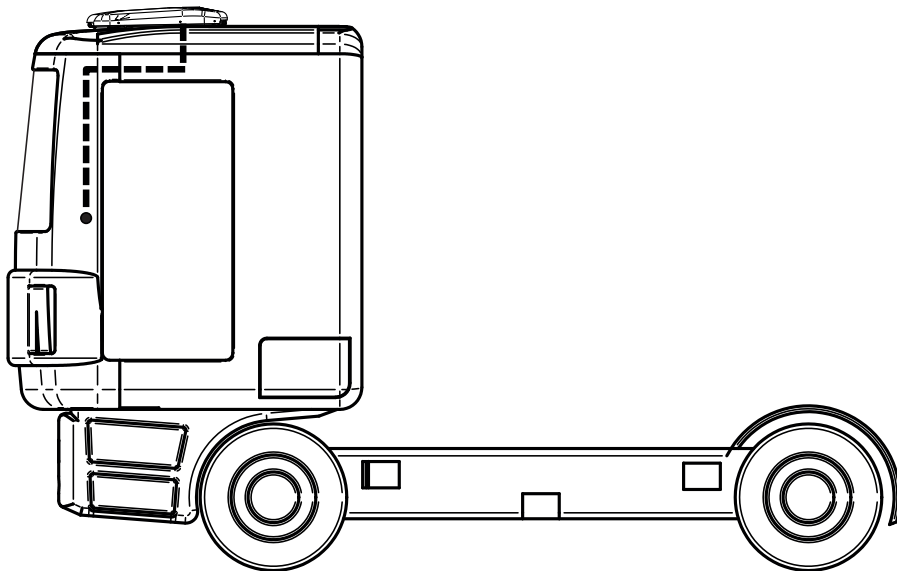

**B** Collegamento della batteria:

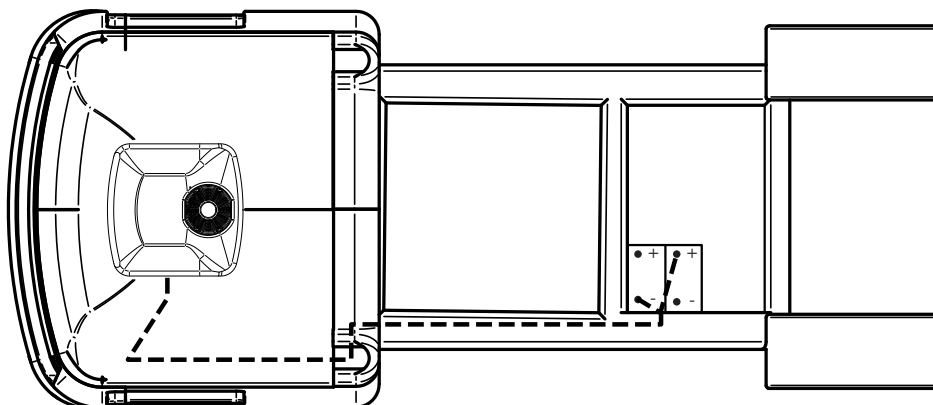

**C** Collegamento nella scatola di connessione della griglia anteriore:

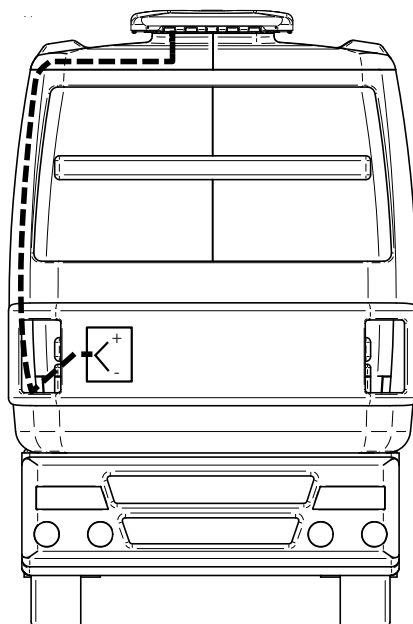

**Importante: Per la messa in funzionamento si dovrà consultare il Manuale dell'Utente.**

Schema elettrico

**AVVERTENZA IMPORTANTE!**

**Fare attenzione** a non invertire le polarità effettuando la connessione dell'alimentazione all'impianto, altrimenti il quadro comandi non si accende e l'impianto non funziona.

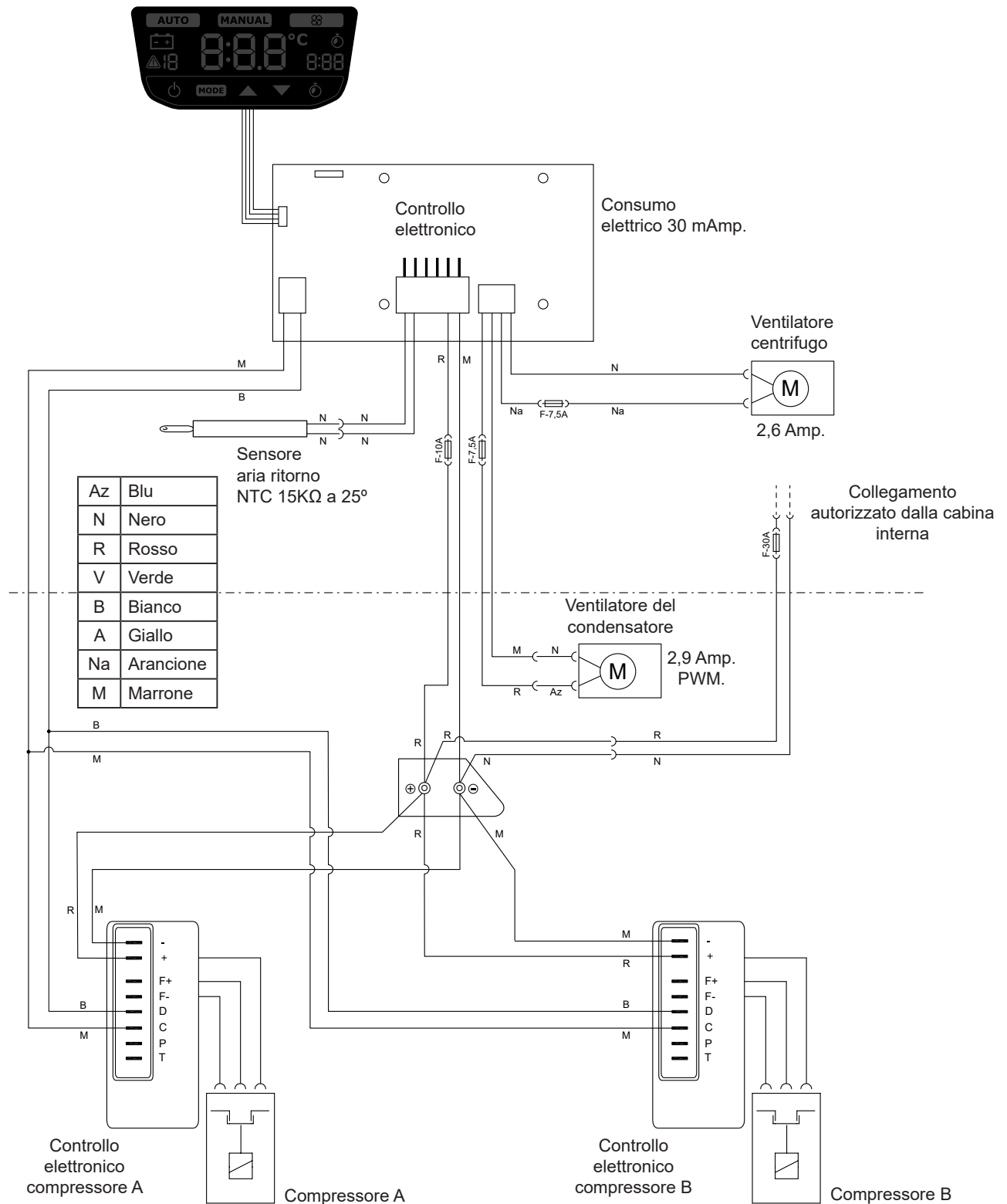









Francisco Alonso, 6  
28806 Alcalá de Henares, Madrid  
SPAIN

Ed:	22/09/2023
Md:	

Contact	Phone	Fax	E-Mail
Sales (Ventas Internacional)	+34 91 8770510	+34 91 8771158	sales@dirna.bergstrominc.com
Comercial Nacional	+34 91 8775841	+34 91 8836321	ventas@dirna.bergstrominc.com
Orders & Deliveries (Logística internacional)	+34 91 8775846	+34 91 8771158	export@dirna.bergstrominc.com
Orders & Deliveries (Logística nacional)	+34 91 8775840	+34 91 8836321	comercial@dirna.bergstrominc.com
Technical Assistance (Internacional)	+49 511 86679681	+49 511 86679710	technicalassistance@dirna.bergstrominc.com
Technical Assistance (Nacional)	+34 91 8775845	+34 91 883 6321	asistenciatecnica@dirna.bergstrominc.com

[www.bergstromspain.com](http://www.bergstromspain.com)

	<b>ATENCIÓN:</b>	Bergstrom se reserva el derecho de efectuar modificaciones en cualquier momento de los datos contenidos en esta publicación, por razones técnicas o comerciales.
	<b>NOTE:</b>	<i>For technical and commercial reasons, Bergstrom reserves the right to change the data contained in this brochure.</i>
	<b>ATTENTION:</b>	Bergstrom se réserve le droit d'effectuer à tout moment des modifications des données reprises sur cette publication, pour des raisons techniques ou commerciales.
	<b>HIWEIS:</b>	<i>Bergstrom behält sich vor, aus technischen oder kaufmännischen Gründen jederzeit Änderungen der Angaben dieser Veröffentlichung vorzunehmen.</i>
	<b>ATTENZIONE:</b>	Bergstrom si riserva il diritto di effettuare modifiche in qualsiasi momento ai dati contenuti in questa pubblicazione, per motivi tecnici o commerciali.