



| | |
|-----------------|---------|
| Dirna Bergstrom | DAF |
| 1003216939 | 1551019 |

Instrucciones de Montaje

Mounting Instructions

Instructions de Montage

- ES**
- EN**
- FR**

Recomendaciones Para el montaje

- Antes de iniciar el montaje leer las instrucciones y seguirlas durante el proceso de instalación.
- Usar las herramientas adecuadas para cada operación.

Electricidad

- Desconectar la llave de contacto.
- Desconectar la batería antes de empezar el montaje.
- Asegurar el conexionado de los componentes eléctricos, verificando su correcto encaje.

Atención

Si durante el montaje el equipo se inclina o se abate la cabina con el equipo montado, se deberá esperar un mínimo de 60 minutos, desde que el equipo quede horizontal, antes de ponerlo en marcha.

Atención

Al instalar el equipo de aire acondicionado en el techo se debe proteger la parte superior de la cabina con un paño ó manta protectora para evitar posibles arañazos. Al instalar **SLIMCOOL** en el techo hay que tener en cuenta que, normalmente, las cabinas que vienen provistas de escotilla, tienen una estructura suficiente para soportar el peso del equipo. Sin embargo, cuando no ocurra así y sea necesario realizar corte en el techo ó incluso si en el caso de llevar escotilla el material no es lo suficientemente resistente (caso de techo de fibra, plástico, etc...) es el instalador el que debe decidir, **bajo su responsabilidad**, sobre la necesidad de reforzar el techo para evitar posibles deformaciones, roturas, entradas de agua, etc... habilitando los medios para que esto no ocurra.

En las cabinas DAF XF 105 altas de techo de fibra se debe tener especial cuidado y únicamente apoyarse en los nervios de la misma para evitar hundimientos en la parte de fibra.

Herramientas

- Juego de Llaves Torx
- Juego de Llaves Allen
- Llave fija 10, 13, 14, 20
- Tijeras
- Flexómetro

Documentación relacionada

| | |
|--------------------------|------------|
| Instrucciones de montaje | 1003272654 |
| Manual del usuario | 1003272655 |
| Diagnóstico de averías | 1003272657 |
| Listado de recambios | 1003216944 |







Documentación incluida

| | |
|-------------|------------|
| Guía rápida | 1003272653 |
| Garantía | 220AA10017 |

Simbología

-  Frágil
-  Atención corte!
-  Riesgo eléctrico

Advertencias

-  El personal instalador debe poseer una formación suficiente en Aire Acondicionado de vehículos.
-  **Dirna Bergstrom** queda exenta de responsabilidad si se producen averías que procedan de una inadecuada manipulación ó instalación del equipo, o por modificaciones y sustituciones efectuadas sin nuestra expresa autorización por escrito.
-  **Equipo precargado con gas refrigerante. (No manipular el circuito de gas refrigerante).**
-  Véase **procedimiento de garantía** del producto incluido en **Diagnóstico de Averías**.
-  Véase **Manual de Usuario** del equipo para el correcto funcionamiento del mando a distancia y del panel de control.
-  Al finalizar la instalación se debe entregar al usuario: **Manual del Usuario, Garantía y Diagnóstico de averías.**

**IMPORTANTE:**

Este documento contiene las instrucciones de montaje para los modelos:

**DAF XF 105 SPACE CAB EURO 5
(SPOILER NO REGULABLE)****DAF XF 105 SPACE CAB EURO 5
(SPOILER REGULABLE)**

**DAF XF SUPER SPACE CAB
EURO 5 Y EURO 6**



EURO 5



EURO 6

**DAF XF SPACE CAB
EURO 6**



DAF XF 105 Space Cab EURO 5 y EURO 6

1

Desmontar tapa escotilla, los elementos de fijación y entregar éstos al cliente (*).

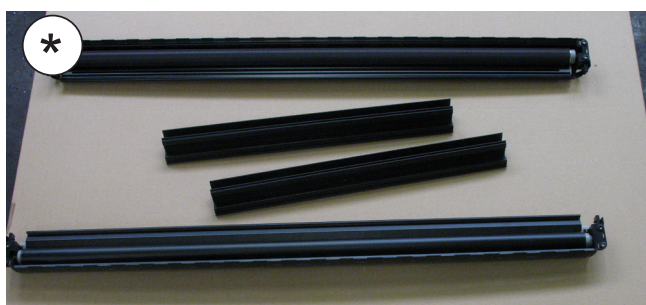

1a

Quitar los residuos sobrantes adheridas al techo antes de pegar la junta EPDM.

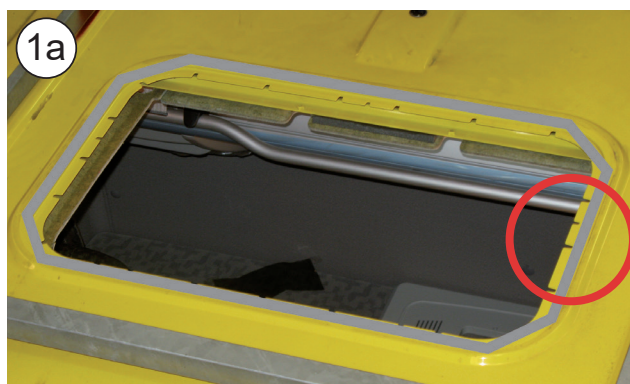

DAF XF 105 Super Space Cab EURO 5 y EURO 6

1b Desmontar embellecedores laterales (*) tirando de ellos y desplazándolos hacia la parte trasera de la cabina.



1c Desmontar embellecedor delantero (*) tirando de el hacia abajo y desconectar clemas de luces.

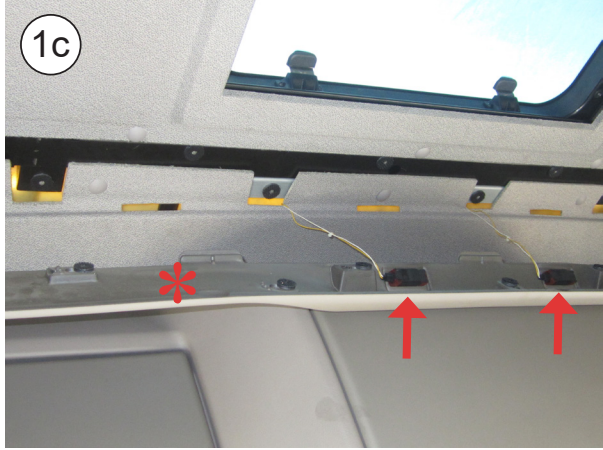

1d Desmontar grupillas de sujeción del tapizado de la parte delantera desde el riel de la cortina con útil especial.



DAF XF 105 Super Space Cab EURO 5 y EURO 6
1e

Desplazando tapizado hacia abajo, desmontar tornillos delanteros de sujeción del riel de cortinilla de la escotilla y desmontar éste.

**1f**

Desmontar marco interior de escotilla (*).

**1g**

Desmontar escotilla quitando tornillos de sujeción y desconectando conector.

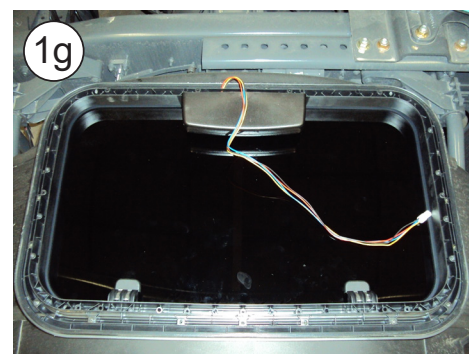
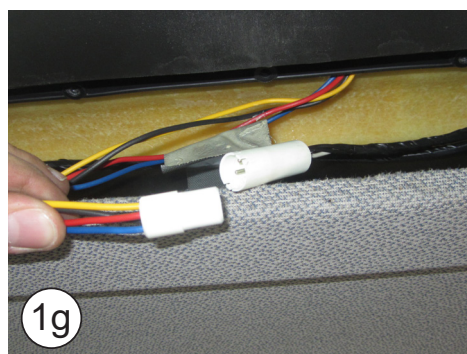

TODOS LOS MODELOS

2 Pegue la junta EPDM alrededor del hueco de escotilla (*mirar el detalle para cortar los bordes finales de unión de la junta*).

- DAFXF105SPACECAB.EURO5SPOILER NO AJUSTABLE - junta 25 x 25.
- DAFXF105SPACECAB.EURO5SPOILER AJUSTABLE - junta 25 x 15.
- DAF XF 105 SUPER SPACE CAB. EURO 5 Y EURO 6 - junta 25 x 25.
- DAF XF SPACE CAB EURO 6 - junta 25 x 25.



! COMO CORTAR LA JUNTA EPDM PARA EVITAR FILTRACIÓN DE AGUA EN LA CABINA

- A-** Pegar la junta, manteniendo 100 mm de papel protector por cada lado.
- B-** Quita los dos piezas de papel.
- C-** Pegue presionado ambos finales.

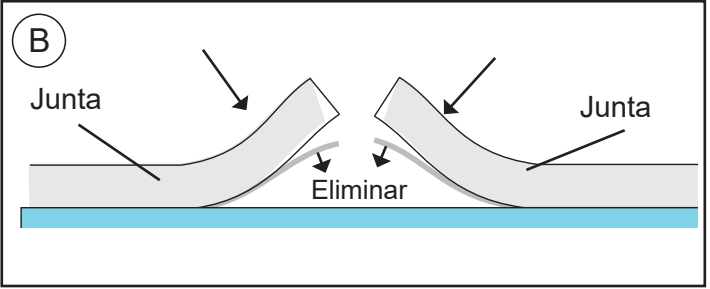
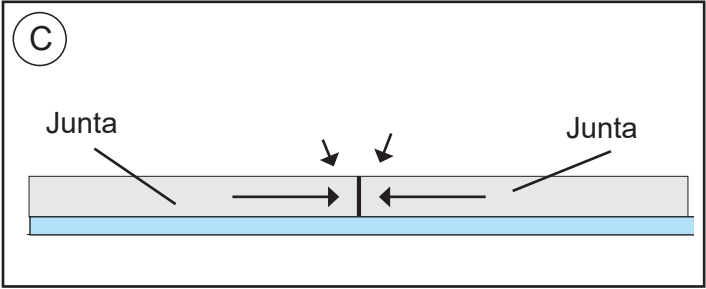
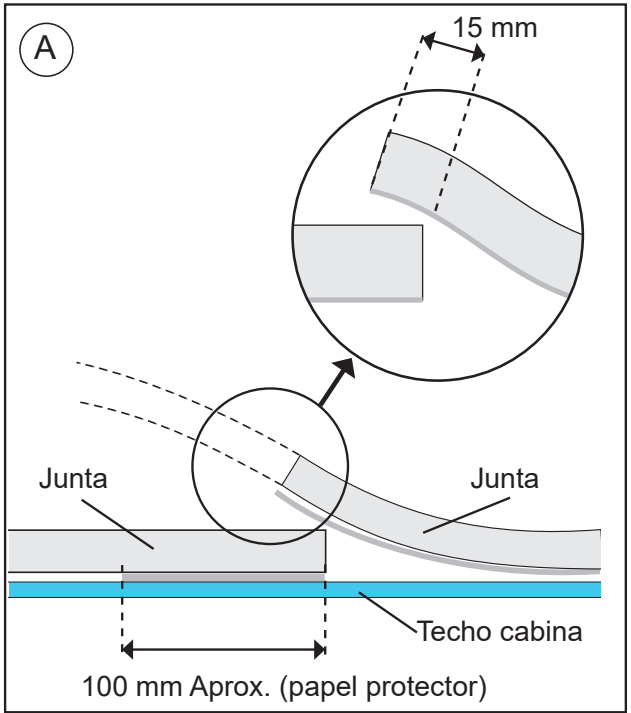

SÓLO PARA MODELOS: DAF XF 105 Super Space Cab EURO 5 y EURO 6
2a

Poner el equipo **SLIMCOOL** en posición vertical, aflojar tornillos de centradores sólo para permitir el desplazamiento de los mismos. Desplazar centradores hacia la parte trasera del equipo hasta que los tornillos hagan tope en las correderas de los centradores y volver a apretar tornillos.

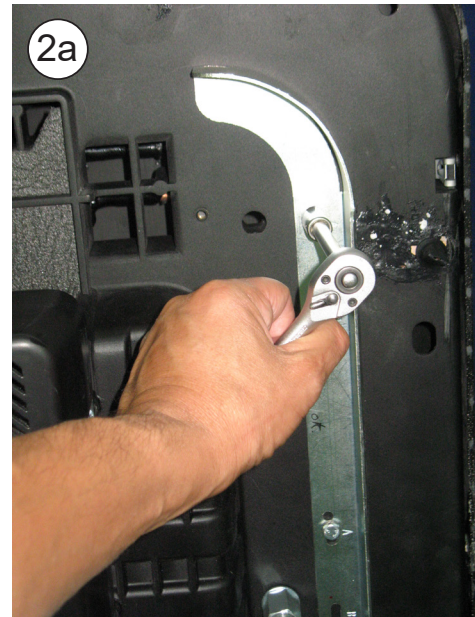
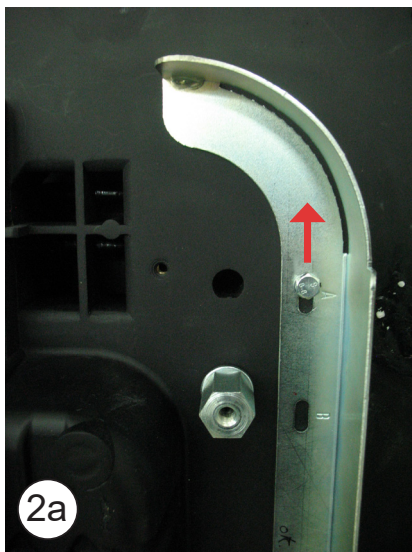
**PARTE DELANTERA
DEL EQUIPO**
**2b**

Roscar (4) hexágonos M8x32 sobre hexágonos de la base y apretar contra los mismos haciendo contratuerca (ver esquema página 13).



TODOS LOS MODELOS

3 EXTERIOR CABINA:
 Posicionar el SLIMCOOL en el hueco de la escotilla, encajando centradores en el mismo.

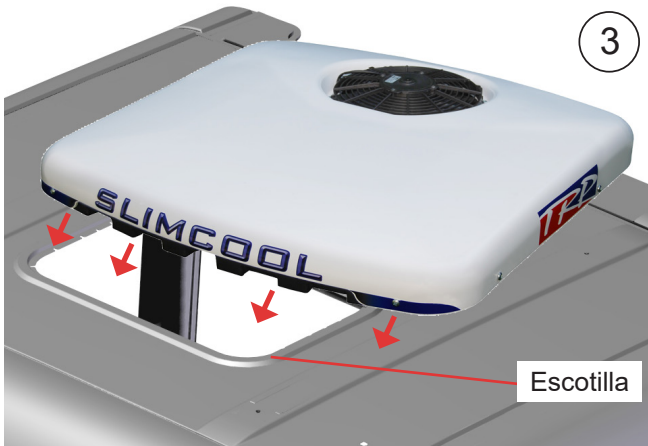

¡Atención!!! Al colocar el equipo en hueco escotilla, verificar que las salidas de desagüe no queden obstruidas por la junta EPDM.

DAF XF 105 Space Cab EURO 5 spoiler no ajustable
 DAF XF 105 Super Space Cab EURO 5 y EURO 6

4 Introducir soportes de fijación por debajo del tapizado y fijar a hexágonos con (4) tornillos 8/125x45, (4) arandelas planas ala ancha Ø 8 y (4) arandelas grower Ø 8 para fijar el equipo apretar hasta que los soportes hagan tope con los hexágonos.



DAF XF 105 Space Cab (EURO 5 spoiler ajustable)**5**

Colocar (2) soportes de fijación como se indica en el esquema, colocar (4) separadores $\varnothing 25 \times 9 \times 10$; (4) tornillos M8/125x55 y apretar hasta hacer tope. (ver esquema página 12).

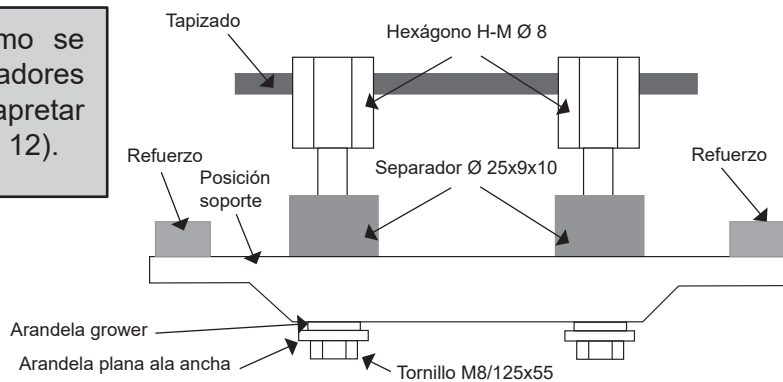

Vista explosionada hasta la fijación de los soportes

DAF XF 105 Space Cab Euro 6
DAF XF 105 Space Cab Euro 5 spoiler no ajustable

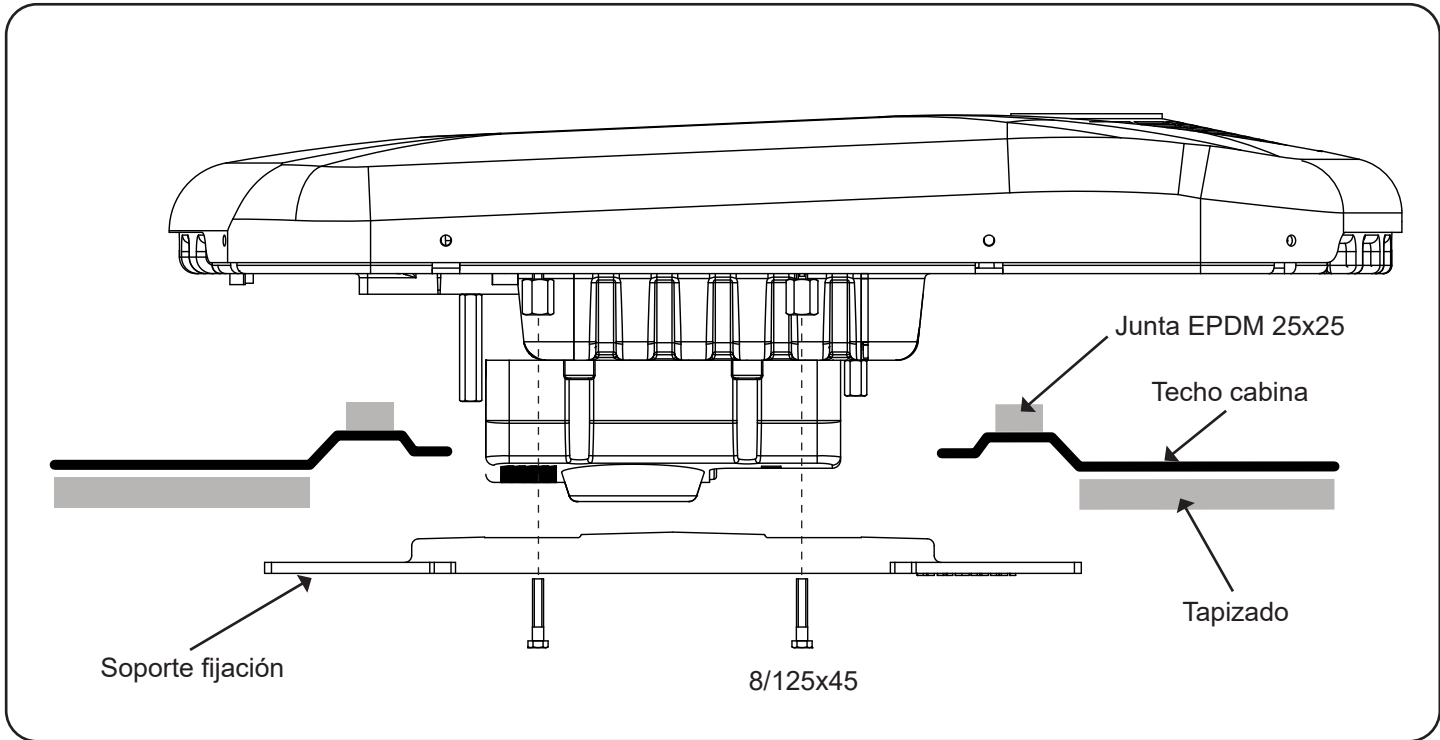

DAF XF 105 Space Cab EURO 5 spoiler ajustable

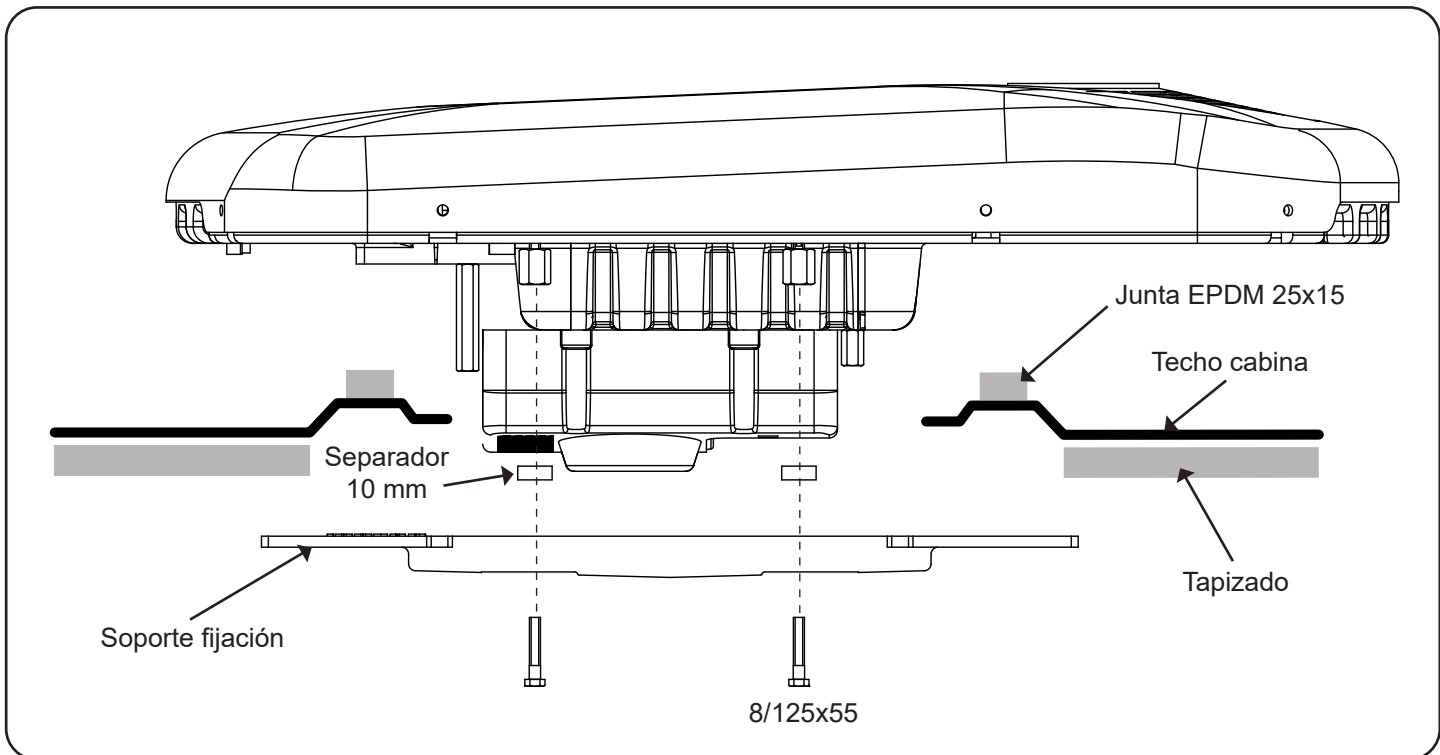

Vista explosionada hasta la fijación de los soportes

DAF XF 105 Super Space Cab EURO 5 y EURO 6

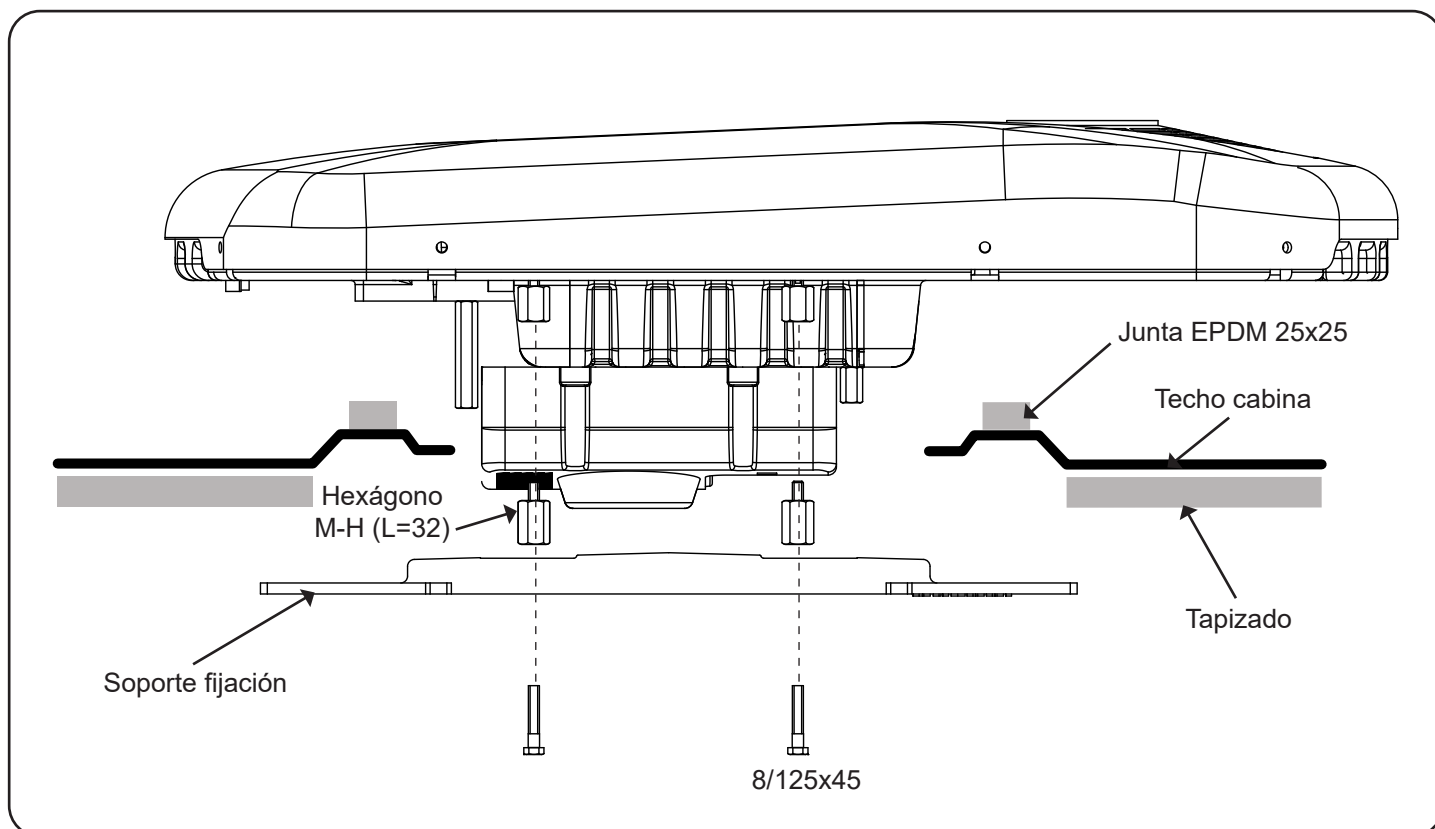

Instrucciones detalladas sobre la conexión del cableado con toma original en escotilla

6

Conectar clema del equipo con clema original situada en el entorno de la escotilla.

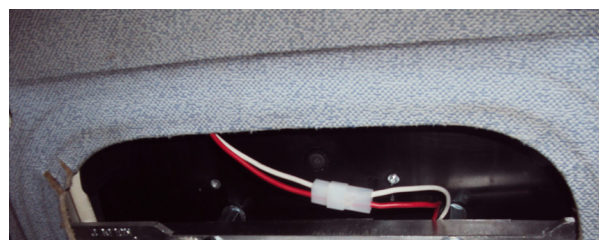

TODOS LOS MODELOS EXCEPTO EURO 6
Instrucciones detalladas sobre la instalación del cableado de alimentación con acceso por guantera superior derecha

6 Abra la cubierta de la guantera superior derecha y quite los dos tornillos del lado inferior. (A)

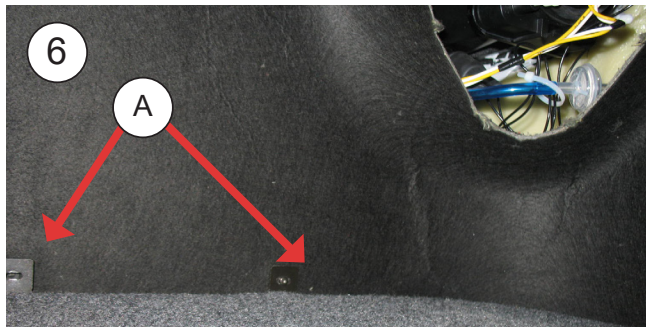

6a Separe ligeramente la guantera e introduzca la mano a través del lado inferior para recoger el cableado original. Esta línea cableada viene protegida por un fusible de 40 amperios existente en las cajas de fusibles originales centrales.



 Si el conector de cableado existente esta ya en uso (por ejemplo: conectado a un microondas). Añadir un nuevo conector de cableado, similar al existente de la caja, desde la guantera a la caja central.

Proteger el cable de suministro de corriente con un nuevo fusible separado de 40Amp. (Reservar el fusible de 40 Amp. en la caja de fusibles central).



6b Dirija la línea cableada de la unidad entre el techo y la tapicería por encima de la guantera y enchufe ambos conectores. Una vez unidos, la unidad realizará una función de comprobación, todas las luces se encenderán y se apagarán, esto quiere decir que la unidad esta lista.

Fije la línea cableada de la unidad al soporte de aluminio como se muestra la imagen usando bridas de plástico.



IMPORTANTE
 El caso de que por error la línea cableada fuera conectada invirtiendo la polaridad, el control electrónico de la unidad emitirá unos pitidos discontinuos. No debe tocarse ninguna tecla ni del panel ni del mando a distancia del equipo porque se pueden producir daños irreparables en el sistema electrónico. A la señal de estos pitidos discontinuos, desconectar el equipo y verificar la polaridad de la conexión.

TODOS LOS MODELOS EXCEPTO EURO 6
Instrucciones detalladas sobre la instalación del cableado de alimentación sin acceso por guantera superior derecha

6 Desmontar barras de desplazamiento de cortinas delanteras aflojando tornillos con llave allen.



6a Desmontar tornillos superiores de guanteras y bascular éstas.



TODOS LOS MODELOS EXCEPTO EURO 6
Instrucciones detalladas sobre la instalación del cableado de alimentación

7 En parte central está ubicado el cable original de alimentación (A); hacer conexión con cable suministrado.

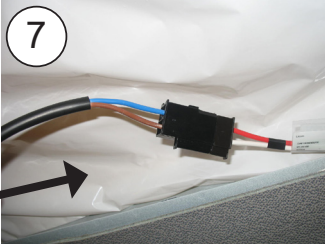
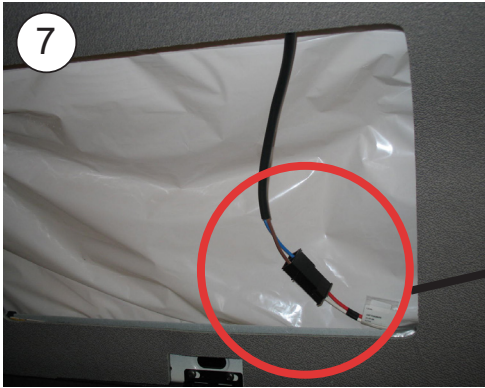
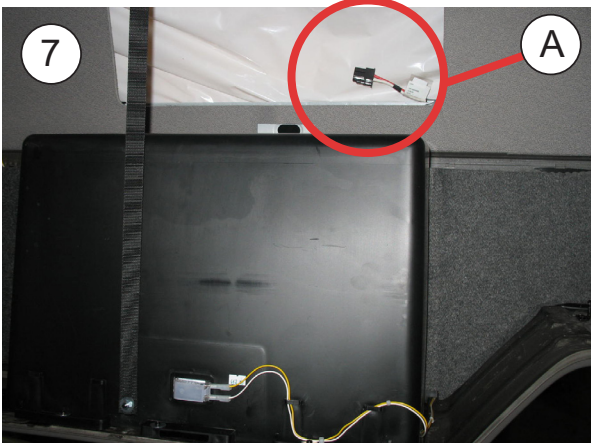

8 Abrir tapa de fusibles y colocar maxifusible de 40 A en lugar del indicado.

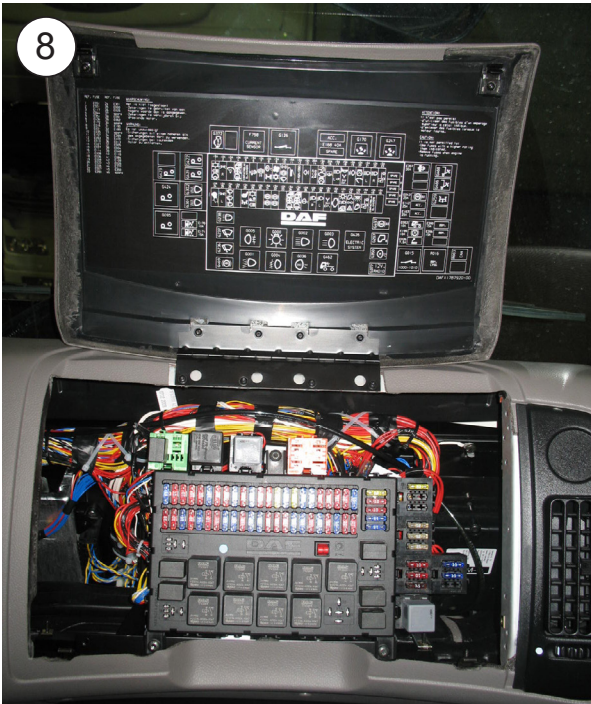

maxifusible 40 A

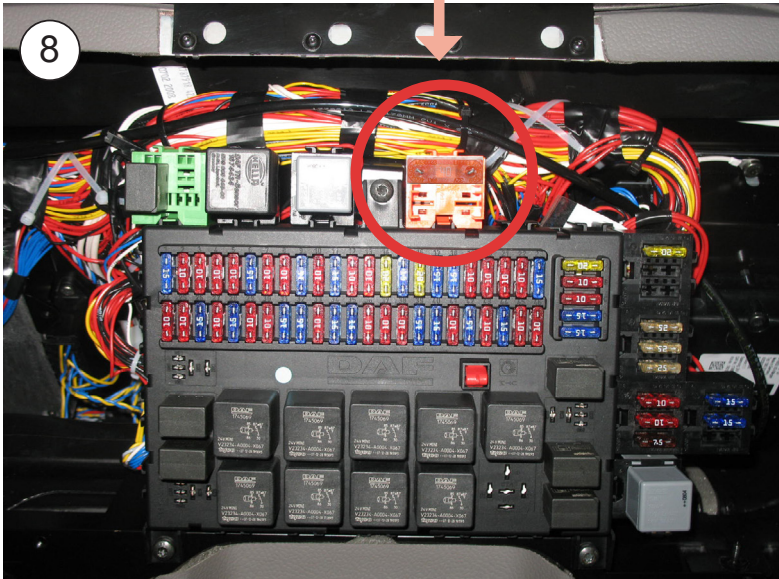

Instrucciones detalladas sobre instalación del cableado modelo Euro 6

9

Por el interior de la cabina desmontar tapas indicadas.

**10**

Desmontar caja de fusibles.

**11**

Pasar el extremo del cable azul con caja suministrado acompañado a cables originales hasta punto A y conectar.

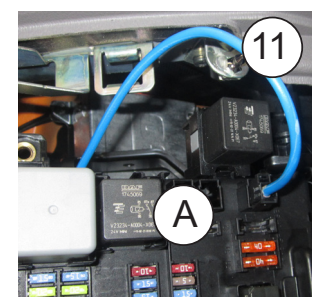
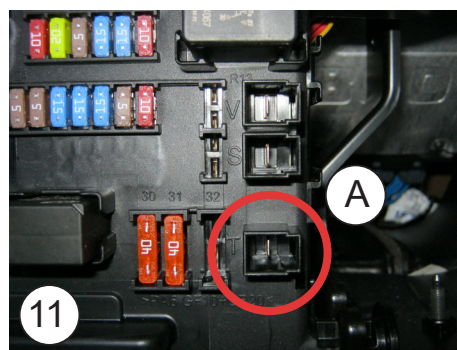
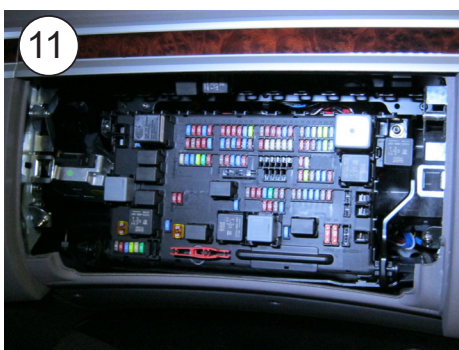

Instrucciones detalladas sobre instalación del cableado modelo Euro 6

12 Colocar fusible de 25A en (B).

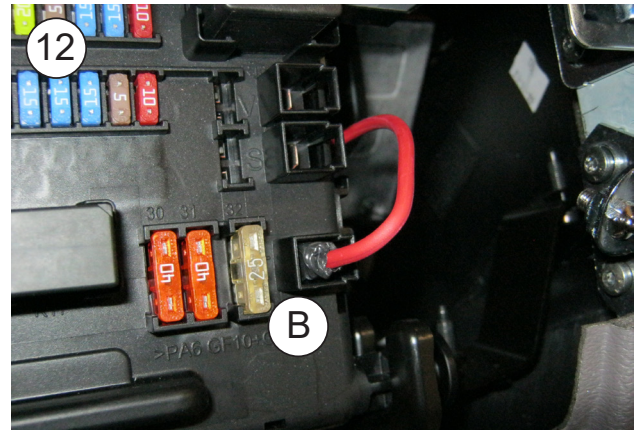

13 Pasar el extremo del cable marrón con caja suministrado acompañado a cables originales hasta punto C y conectar.

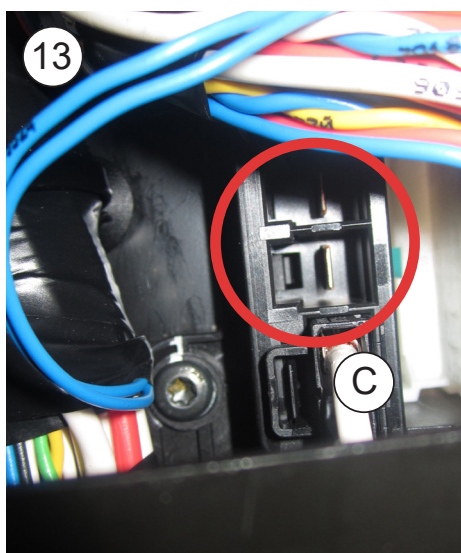
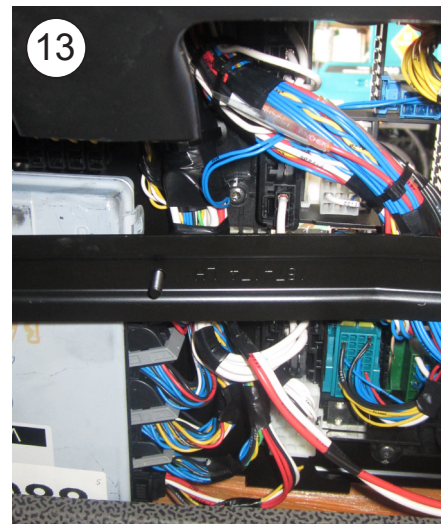

Instrucciones detalladas sobre instalación del cableado modelo Euro 6

14

Abrir guantera superior derecha (D) y desmontar tapa (E).

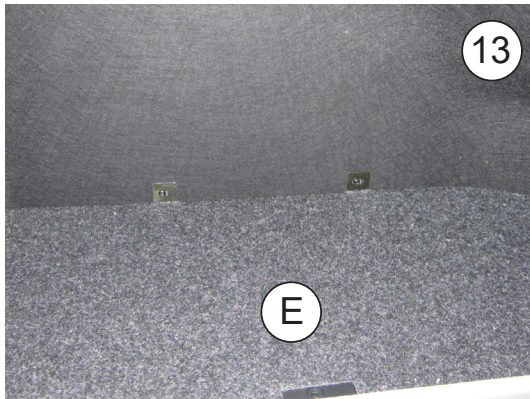
**15**

Por tubo corrugado ubicado en parte inferior lado pasajero, introducir cable Az y M y sacarlo por el extremo del tubo que sale por la guantera superior derecha.

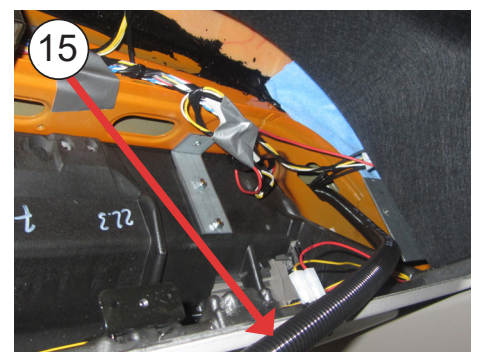
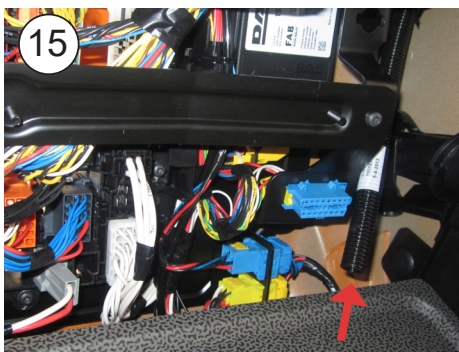
**16**

Grapar terminales suministrados en cables Az y M e introducir en caja suministrada haciendo coincidir colores con los de la caja del cableado suministrado.

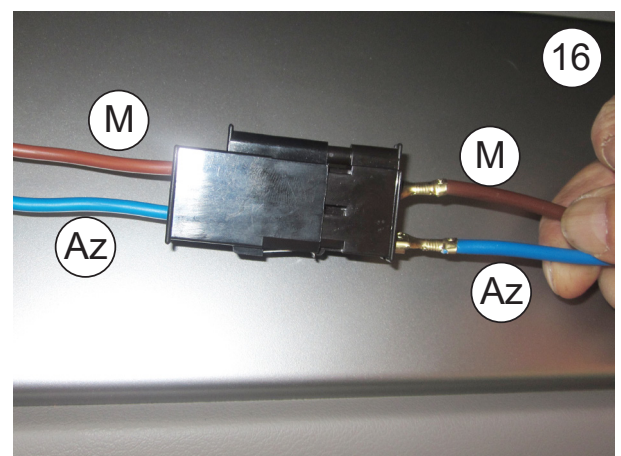

Instrucciones detalladas sobre instalación del cableado modelo Euro 6

17 Conectar cajas de cableados y llevar cableado por detrás de las guanteras originales y el tapizado hasta el equipo y conectar con el mismo.

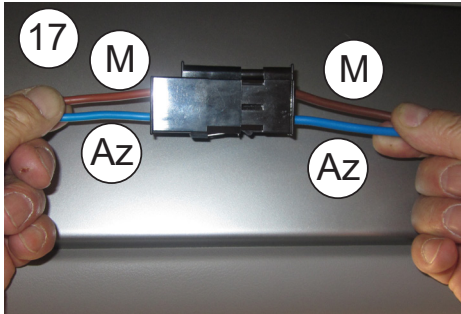

18 Para vehículos DAF XF 105 Space Cab fabricados desde el 10/09/2012 en adelante se deben sustituir los hexágonos M-H M6 L78 y L36 roscados en la base del equipo por los hexágonos M-H M6 de L68 Y L26 respectivamente antes de montar la consola. Ver esquemas adjuntos.

DAF XF 105 Super Space Cab EURO 5 y EURO 6

Vista explosionada lateral hasta la fijación de las consolas

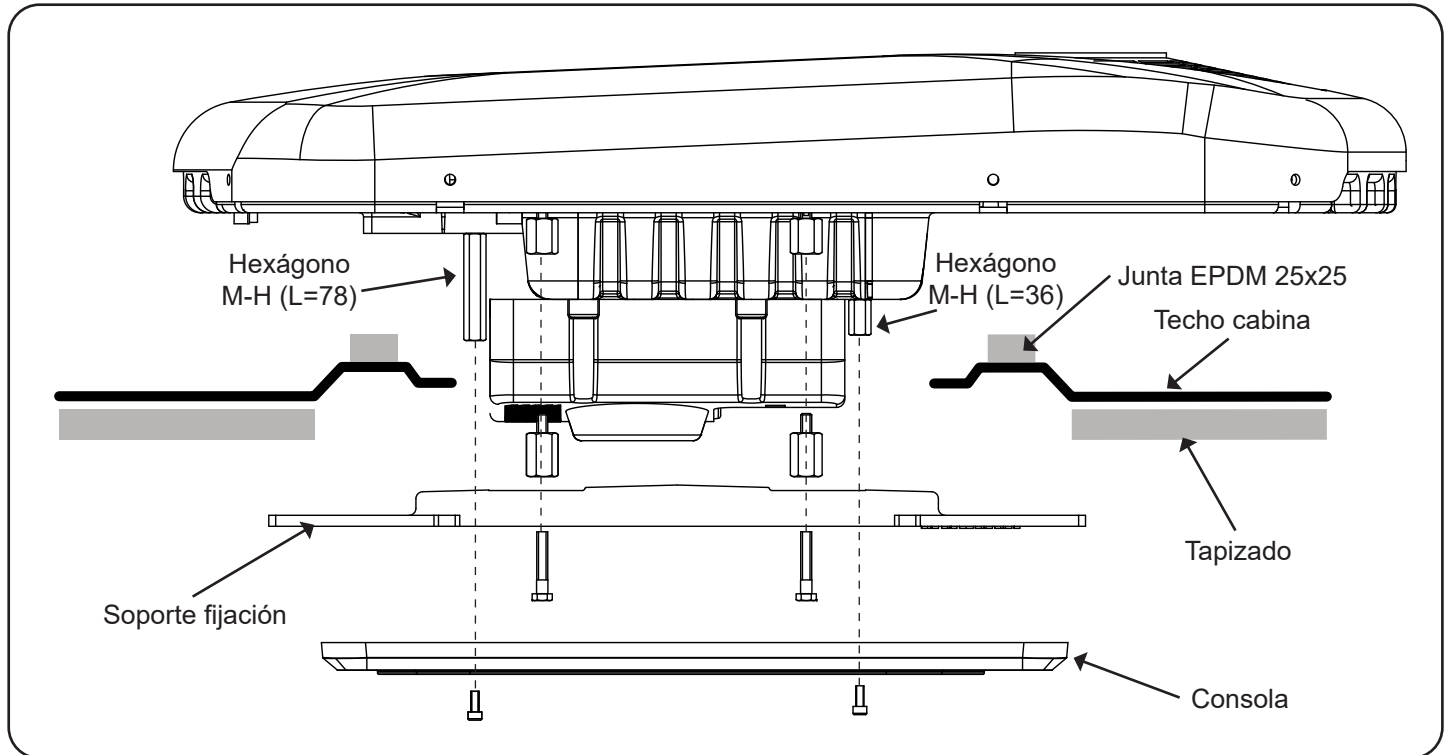

Vista explosionada frontal hasta la fijación de las consolas

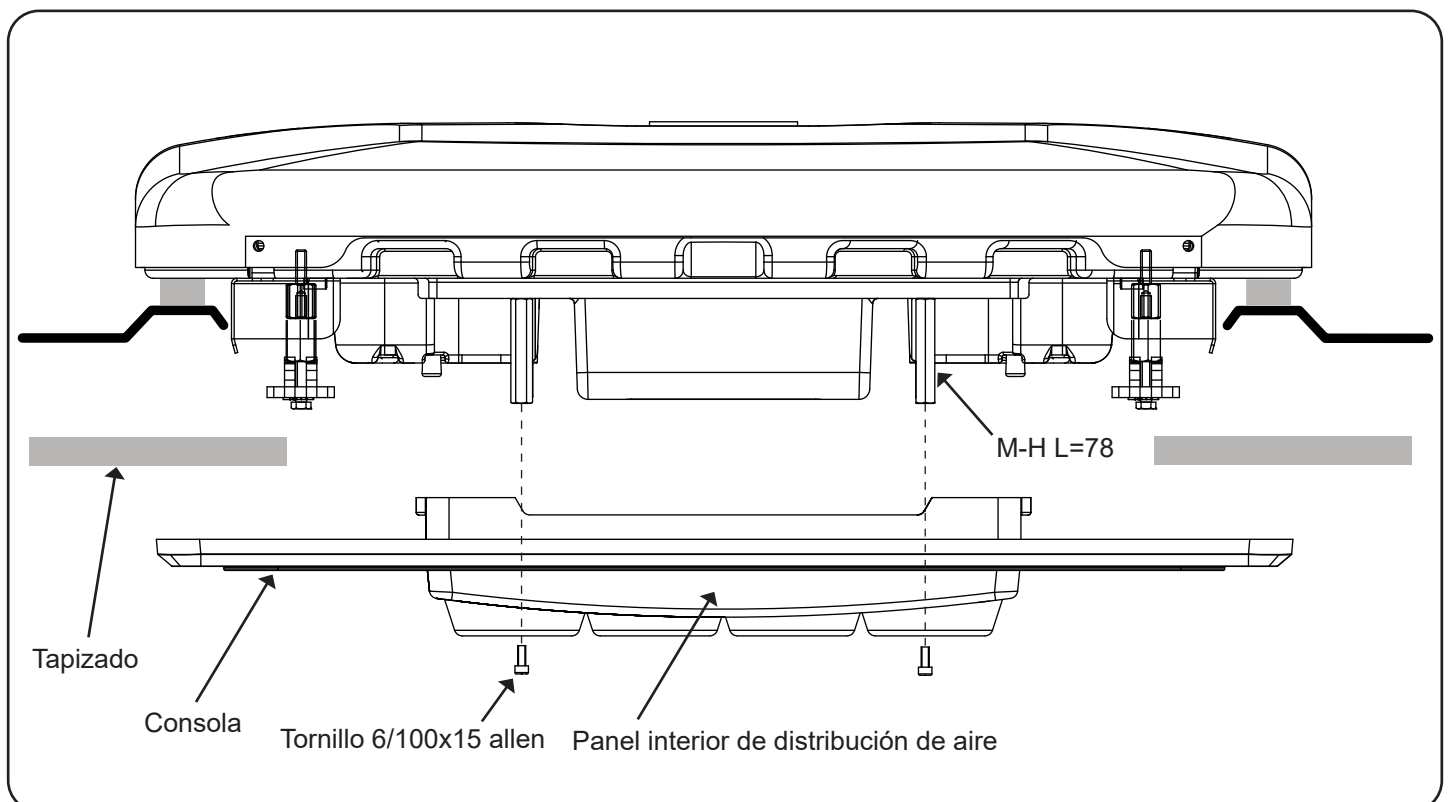

**DAF XF 105 Space Cab EURO 5 spoiler no ajustable
DAF XF 105 Space Cab EURO 6**

Vista explosionada lateral hasta la fijación de las consolas

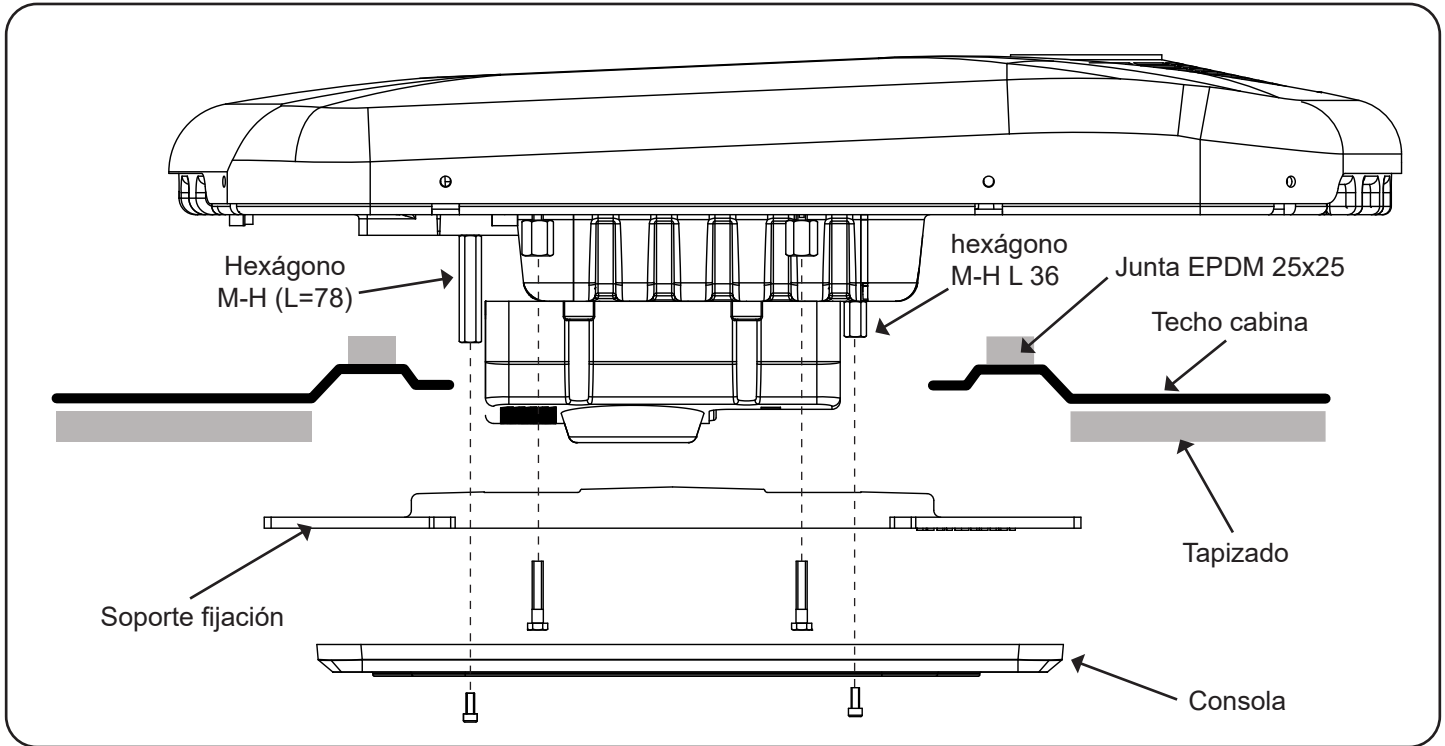

Vista explosionada frontal hasta la fijación de las consolas

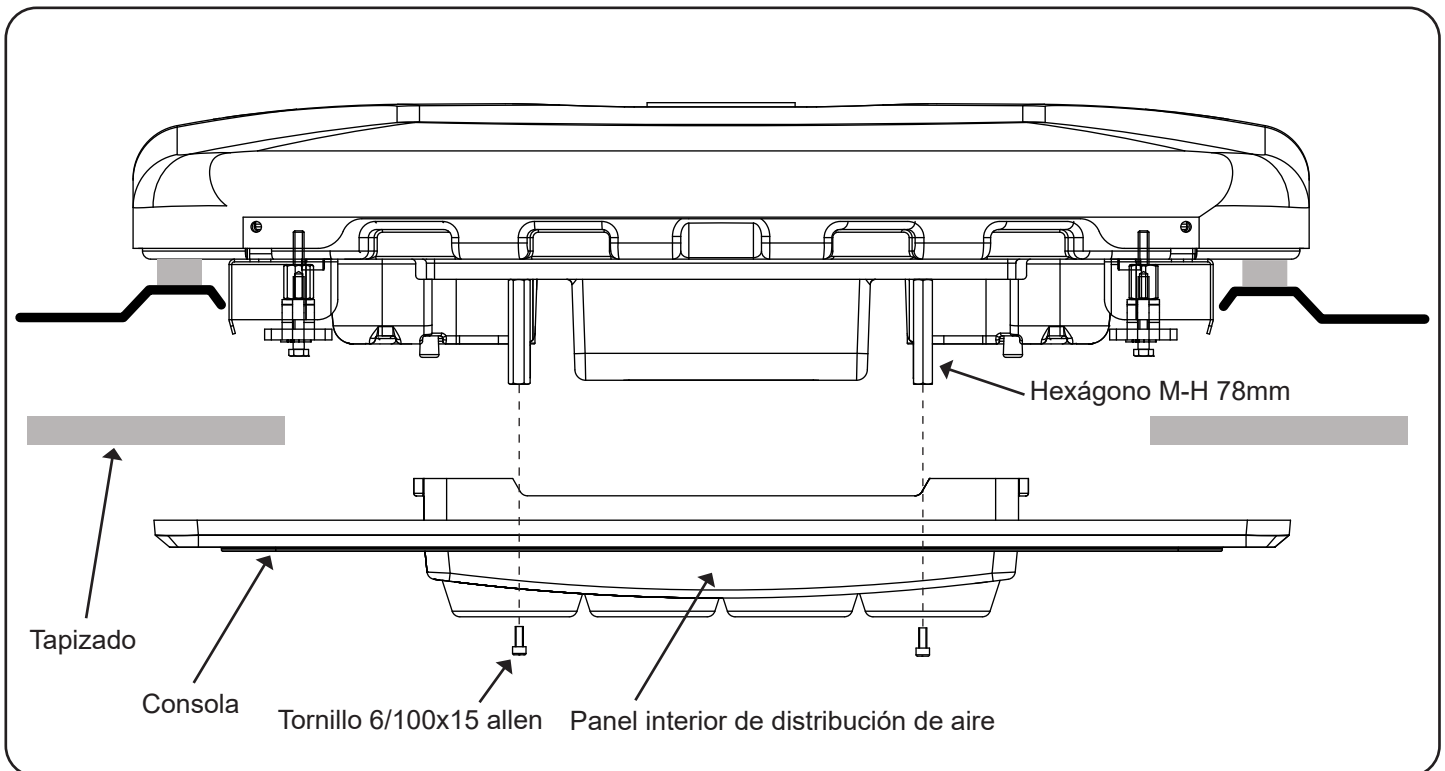

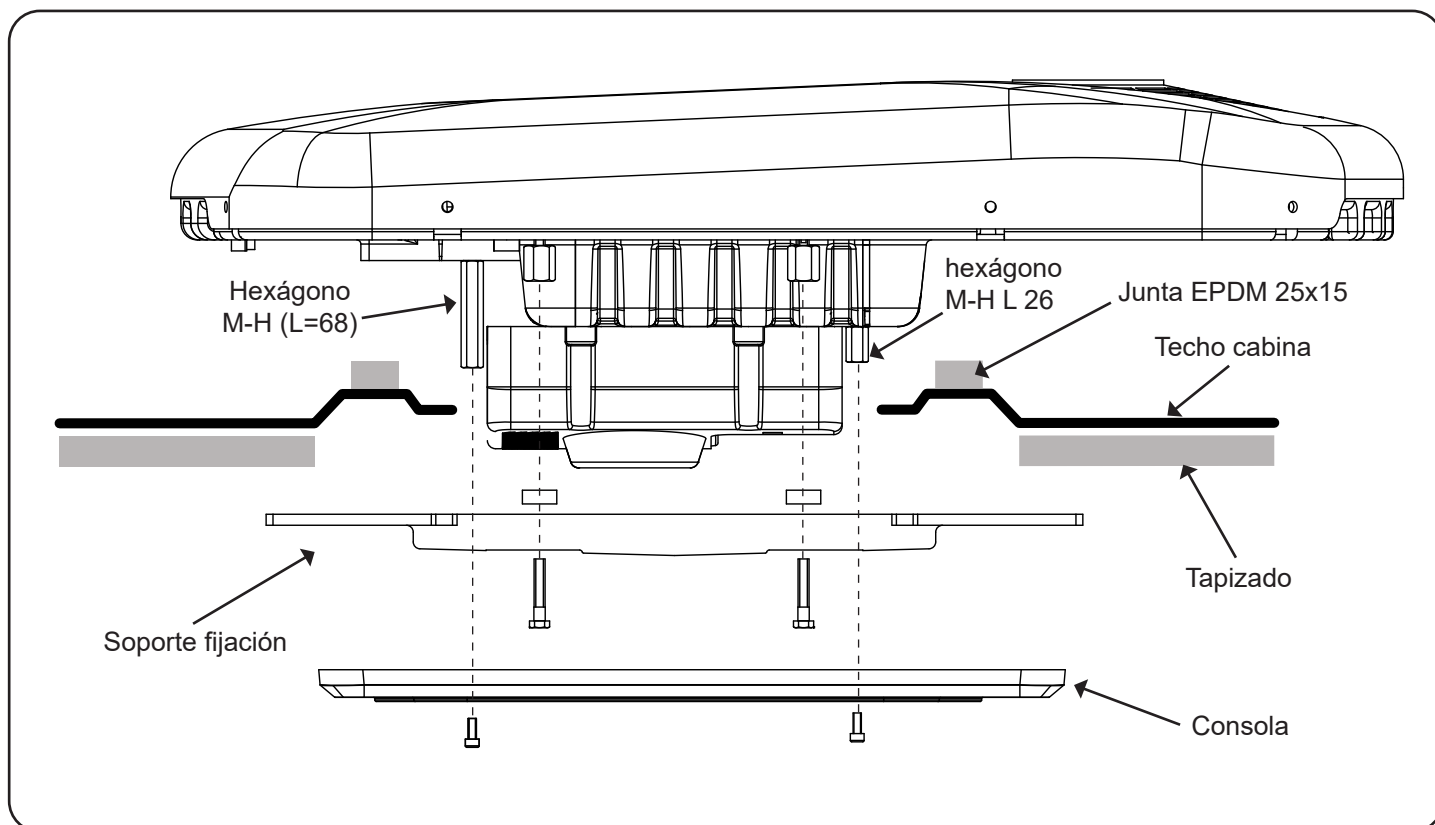
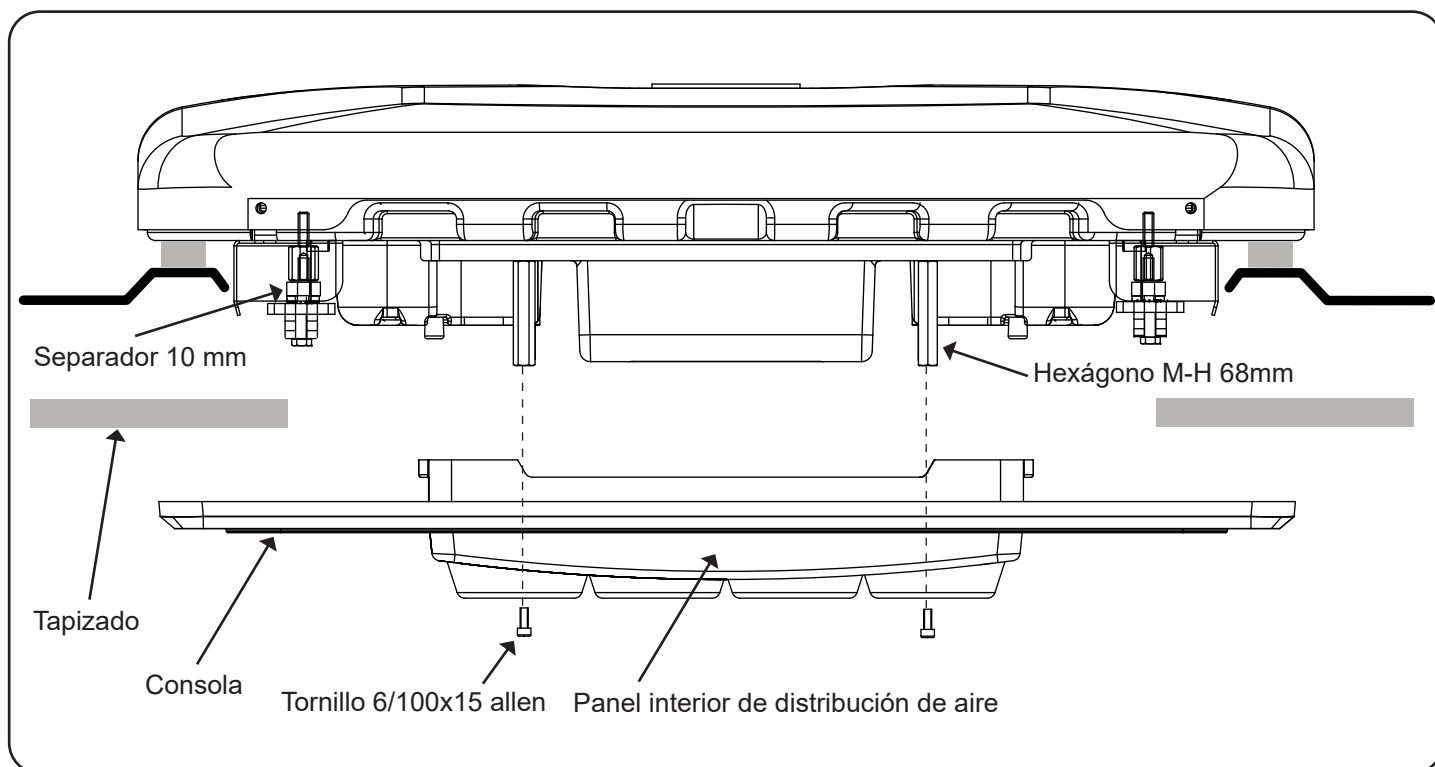
DAF XF 105 Space Cab EURO 5 spoiler ajustable
Vista explosionada lateral hasta la fijación de las consolas

Vista explosionada frontal hasta la fijación de las consolas

TODOS LOS MODELOS**18**

Volver a montar embellecedores originales en su posición.

Montar consola sobre hexágonos H-H con (4) tornillos 6/100x15 allen, posicionando la parte más corta de la consola, en la parte delantera de la cabina.

**19**

Cubrir los (4) tornillos M6/100x15 allen con los embellecedores redondos de M6 de plástico.



TODOS LOS MODELOS CON TOMA ORIGINAL EN ESCOTILLA

Esquema eléctrico

¡AVISO IMPORTANTE!

Precaución de no invertir las polaridades al conectar la alimentación en el equipo el display no se enciende y el equipo no funciona.

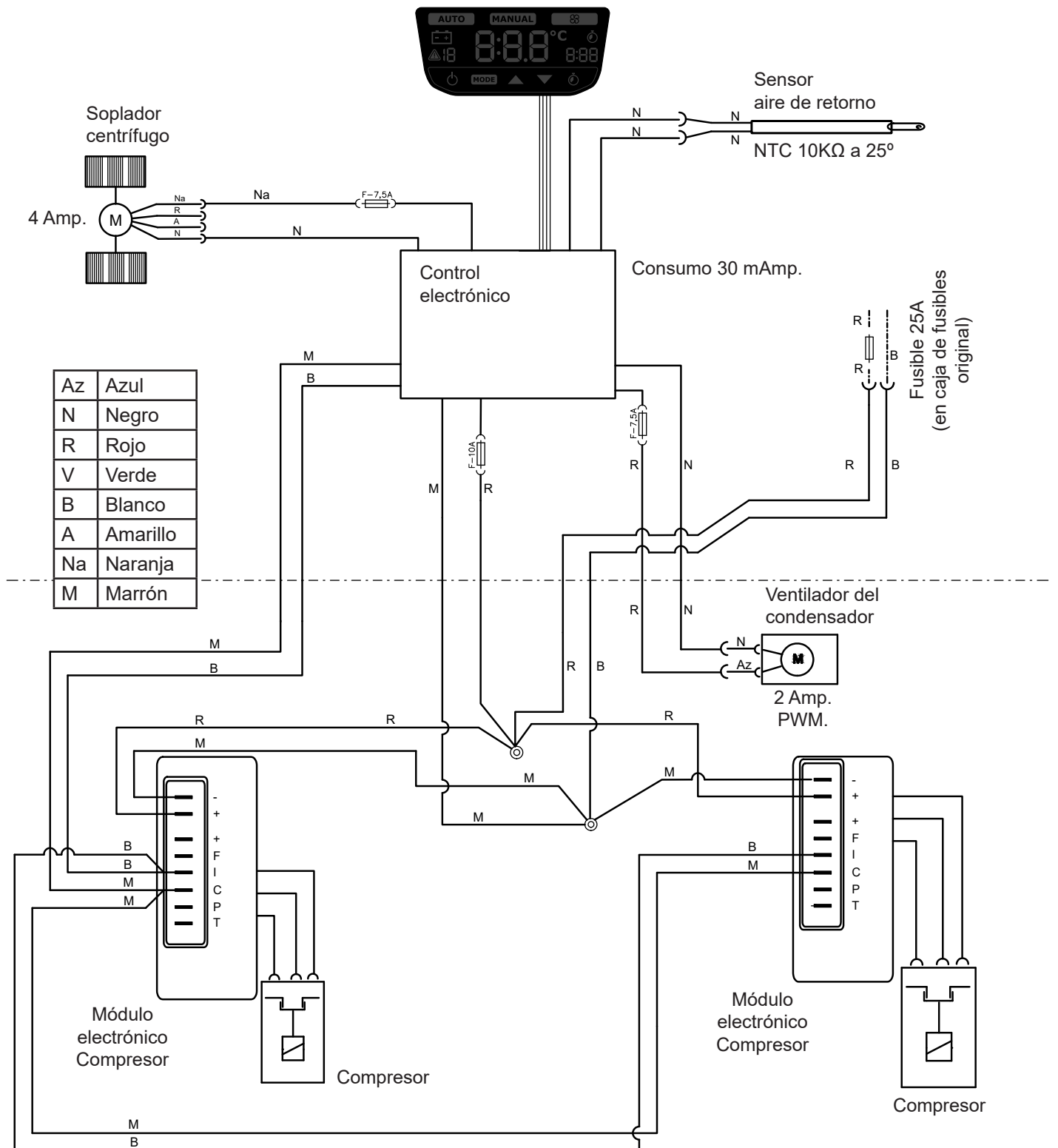

TODOS LOS MODELOS EURO 5 DETRÁS DE LAS GUANTERAS

Esquema eléctrico

¡AVISO IMPORTANTE!

Precaución de no invertir las polaridades al conectar la alimentación en el equipo el display no se enciende y el equipo no funciona.

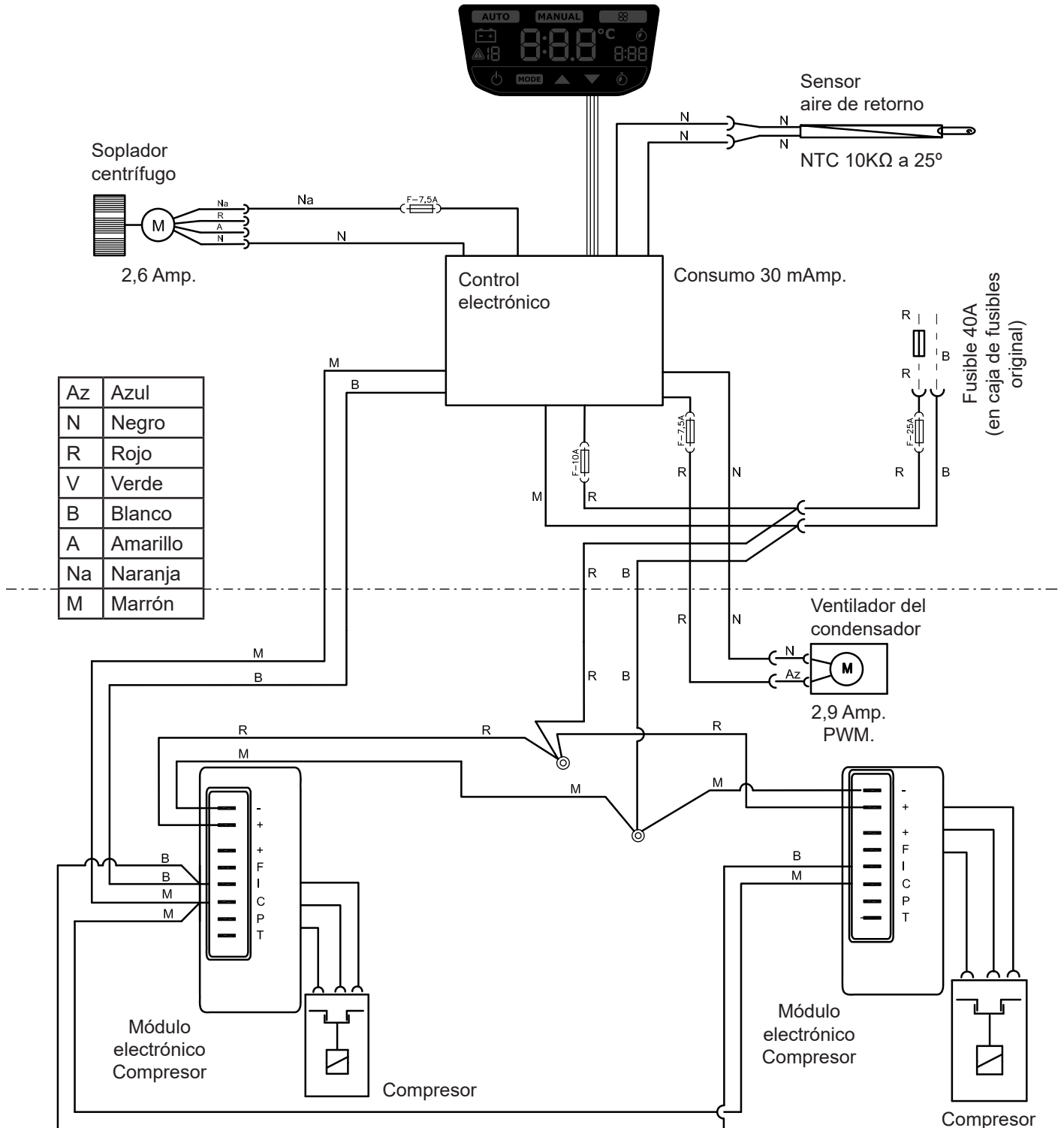

MODELOS EURO 6 SIN TOMA ORIGINAL EN ESCOTILLA Esquema eléctrico

¡AVISO IMPORTANTE!

Precaución de no invertir las polaridades al conectar la alimentación en el equipo el display no se enciende y el equipo no funciona.

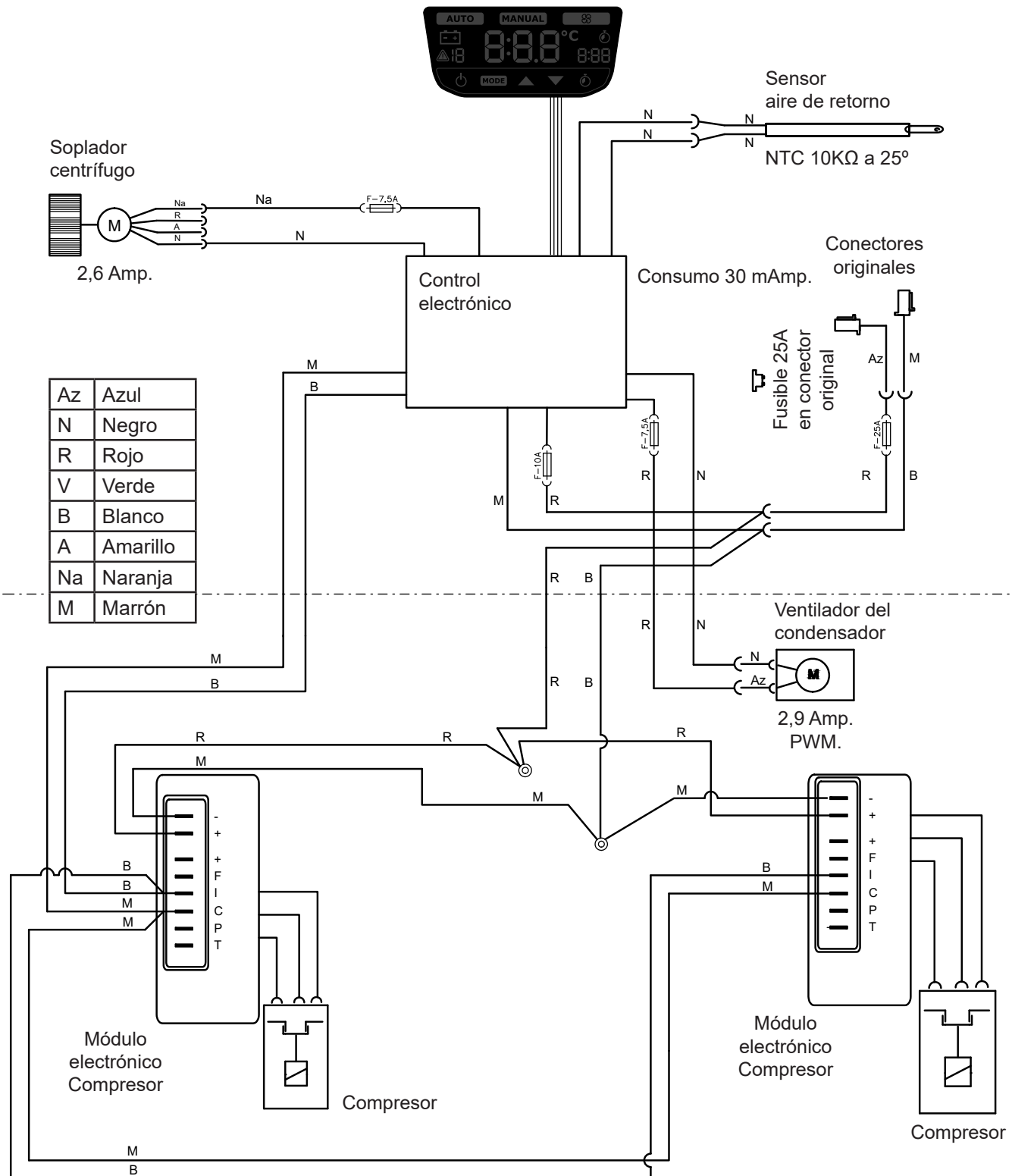

Assembly Recommendations

- Before starting assembly, please read instructions and follow them during installation process.
- Use the adequate tools for each operation.

Electricity

- Disconnect ignition key.
- Disconnect battery before starting assembly.
- Make sure electric components are securely connected, checking their correct fitting.

Warning

If the unit slants during assembly, wait for at least 60 minutes with the unit in horizontal position before starting it up.

Warning

When installing air conditioning equipment on roof, the upper cabin part must be protected with a cloth or a protective blanket to avoid possible scratches. When installing **SLIMCOOL** on roof, take into account that, normally, cabins equipped with a hatch have a strong enough structure to hold equipment weight. However, if it is not the case and it is necessary to carry out a cut in the roof or, although it has a hatch, the material is not resistant enough (if roof is made of fibre, plastic, etc...), it is the installer who will have to decide, **under his responsibility**, if it is necessary to reinforce the roof to avoid possible deformations, breaks, water entries, etc., habilitating the means required to stop it from occurring.

With DAF XF 105 high, plastic roof cabins, take special care and only rest on cabin nerves to avoid fibre part from sinking.

Tools

- Torx wrenches set
- Allen wrenches set
- Open-jawed spanner 10, 13, 14, 20
- Scissors
- Flexo-meter



Related documentation

| | |
|-----------------------|------------|
| Mounting instructions | 1003272654 |
| User's guide | 1003272655 |
| Troubleshooting | 1003272657 |
| Parts list | 1003216944 |







Documentation included

| | |
|-------------|------------|
| Quick guide | 1003272653 |
| Warranty | 220AA10017 |

Symbology

-  Fragile
-  Beware of cuts!
-  Electrical hazard

Warnings

-  The installing personnel must have a sufficient training in vehicles air conditioning.
-  **Dirna Bergstrom** shall not be responsible for breakdowns or damages coming from an inadequate handling or installation of the equipment or from modifications and substitutions carried out without our express and written authorisation.
-  **Equipment pre-charged with refrigerating gas. (Do not handle refrigerating gas circuit).**
-  **Please see product warranty procedure included in Troubleshooting.**
-  Please see equipment User's Guide for its correct functioning of the remote control and control panel.
-  Once installation is finished, the following documents must be handed over to the user: **User's Guide, Warranty and Troubleshooting.**

**IMPORTANT:**

This document contains assembly instructions for the following models:

**DAF XF 105 SPACE CAB EURO 5
(NON-ADJUSTABLE SPOILER)****DAF XF 105 SPACE CAB EURO 5
(ADJUSTABLE SPOILER)**

**DAF XF SUPER SPACE CAB
EURO 5 AND EURO 6**



EURO 5



EURO 6

**DAF XF SPACE CAB
EURO 6**



DAF XF 105 Space Cab EURO 5 and EURO 6

1 Take down the hatch cover and the attachment elements, and hand them over to the customer (*).

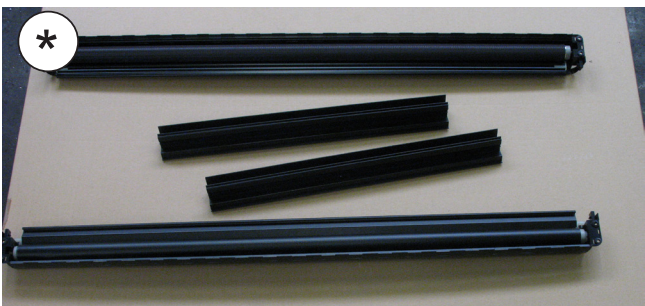

1a Remove any excess from the roof before attaching the EPDM seal.

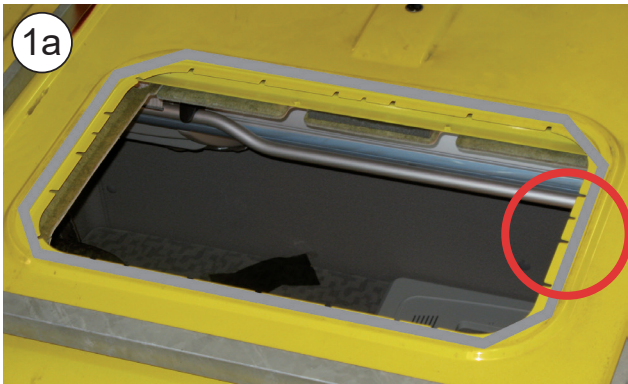

DAF XF 105 Super Space Cab EURO 5 and EURO 6

1b Remove the side decorative pieces (*) by pulling on them and moving them to the back of the cab.

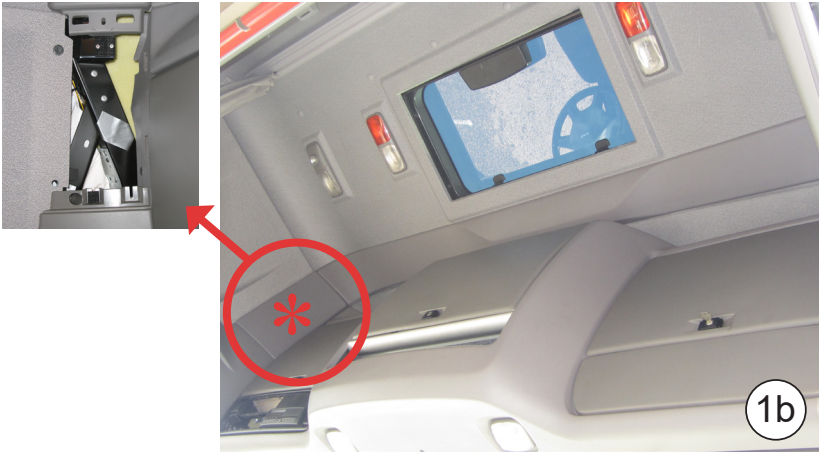

1c Remove the front decorative piece (*) by pulling it downwards, and disconnect the light terminals.

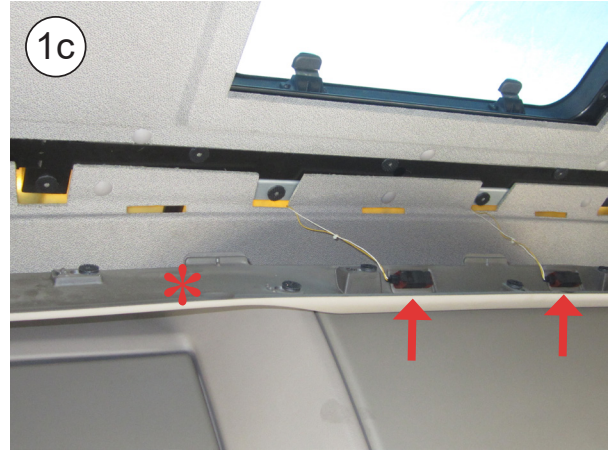

1d Carefully remove the front upholstery circlips from the curtain rail.



DAF XF 105 Super Space Cab EURO 5 and EURO 6

1e Move the upholstery downwards and remove the front screws which support the hatch curtain rail, and remove it.



1f Take down the inside hatch frame (*).



1g Take down the hatch by removing the support screws and disconnecting the connector.

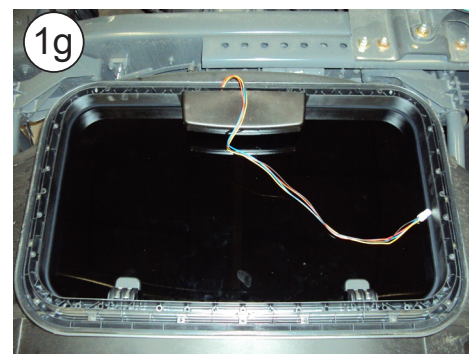
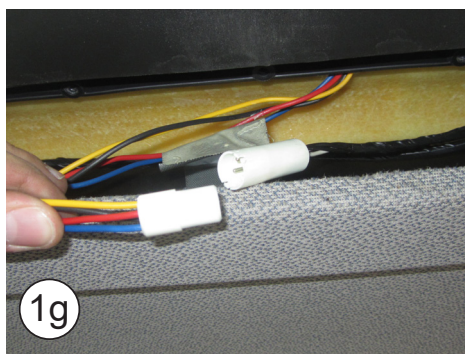

ALL MODELS

2 Attach the EPDM seal around the hatch gap (see the details to cut the ends of the seal joint).

- DAF XF 105 SPACE CAB. EURO 5 NON-ADJUSTABLE SPOILER - 25 x 25 seal.
- DAF XF 105 SPACE CAB. EURO 5 ADJUSTABLE SPOILER - 25 x 15 seal.
- DAF XF 105 SUPER SPACE CAB. EURO 5 and EURO 6 - 25 x 25 seal.
- DAF XF SPACE CAB EURO 6 - 25 x 25 seal.



 **HOW TO CUT THE EPDM SEAL TO PREVENT WATER FROM DRIPPING IN THE CABIN**

- A-** Attach the seal, keeping 100 mm of protection paper on each side.
- B-** Remove the two pieces of paper.
- C-** Attach by pressing both ends.

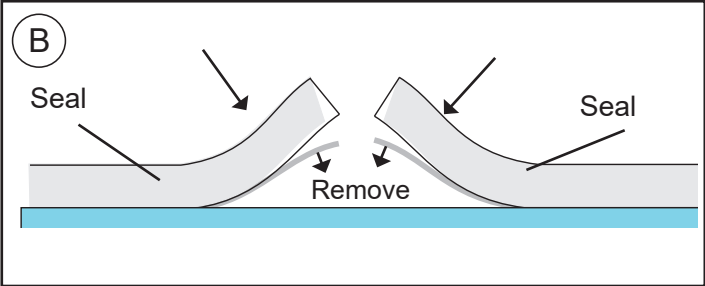
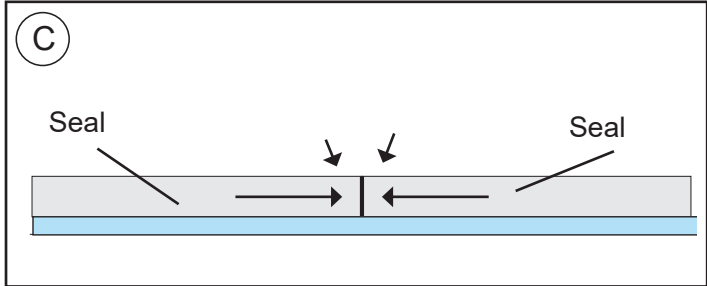
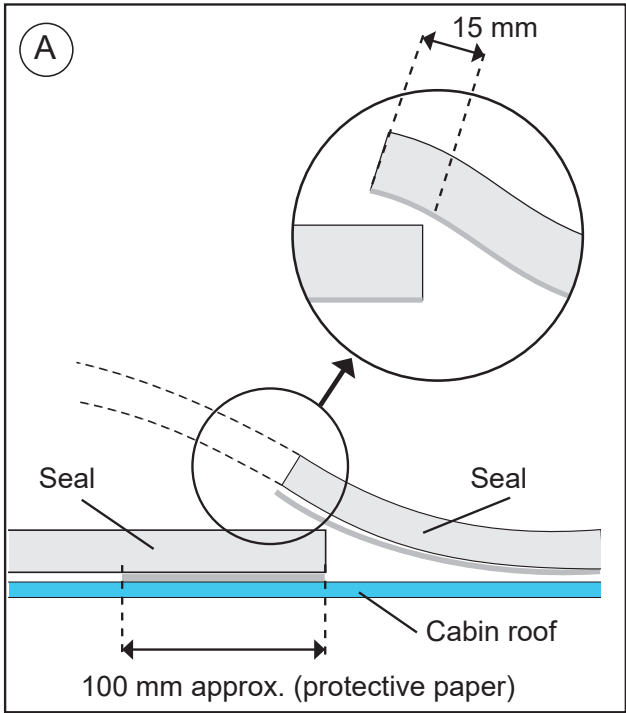

ONLY FOR MODELS: DAF XF 105 Super Space Cab EURO 5 and EURO 6

2a Place the **SLIMCOOL** unit in upright position and slightly loosen the screws of the aligners so they can be moved. Move the aligners to the back of the unit, until the screws come up against the aligner slides, and retighten the screws.



FRONT PART OF THE UNIT

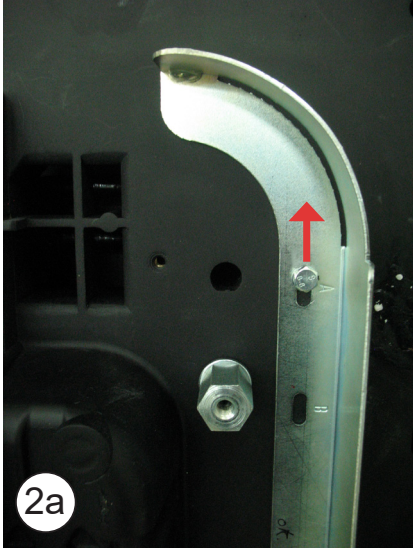

2b Screw (4) M8x32 hexagons on the base hexagons and tighten by way of counter nut (see diagram on page 38).



ALL MODELS

3 CABIN EXTERIOR:
Position the **SLIMCOOL** unit in the hatch gap and fit the aligners.

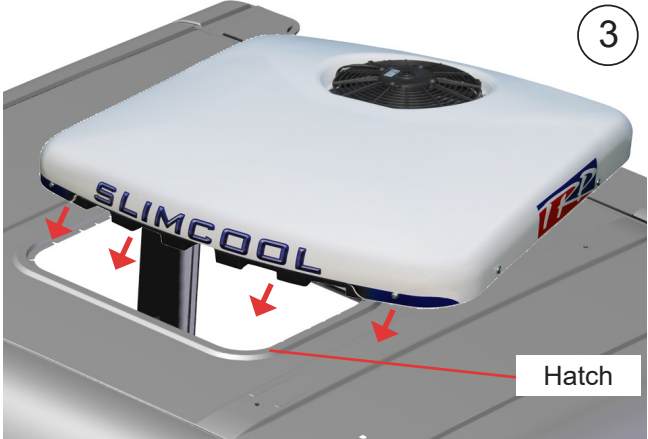

Caution! When positioning the unit above the hatch gap, check that the wastewater run-offs are not blocked by the EPDM seal.

DAF XF 105 Space Cab EURO 5 non-adjustable spoiler
DAF XF 105 Super Space Cab EURO 5 and EURO 6

4 Introduce fastening supports underneath the upholstery and secure to hexagons with (4) 8/125x45 screws, (4) Ø8 flat wide-rimmed washers and (4) Ø8 grower washers, and secure the unit by tightening until the supports come up against the hexagons.



DAF XF 105 Space Cab (EURO 5 adjustable spoiler)**5**

Position (2) attachment supports as indicated in the diagram, (4) Ø25x9x10 spacers; (4) M8/125x55 screws and tighten as much as possible. (see diagram page 37).

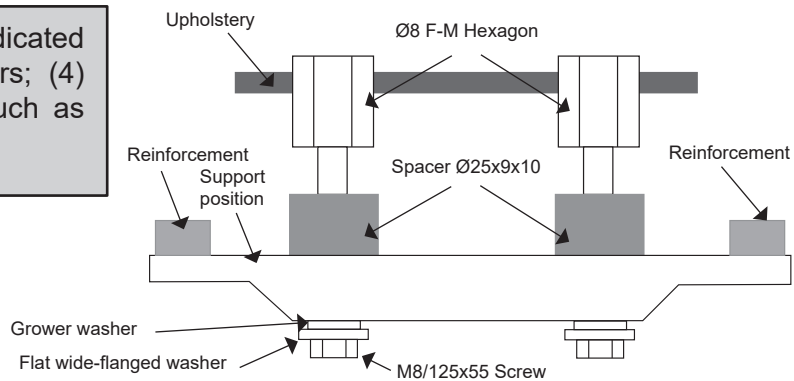

Exploded view through to the support attachment

DAF XF 105 Space Cab Euro 6
DAF XF 105 Space Cab EURO 5 non-adjustable spoiler

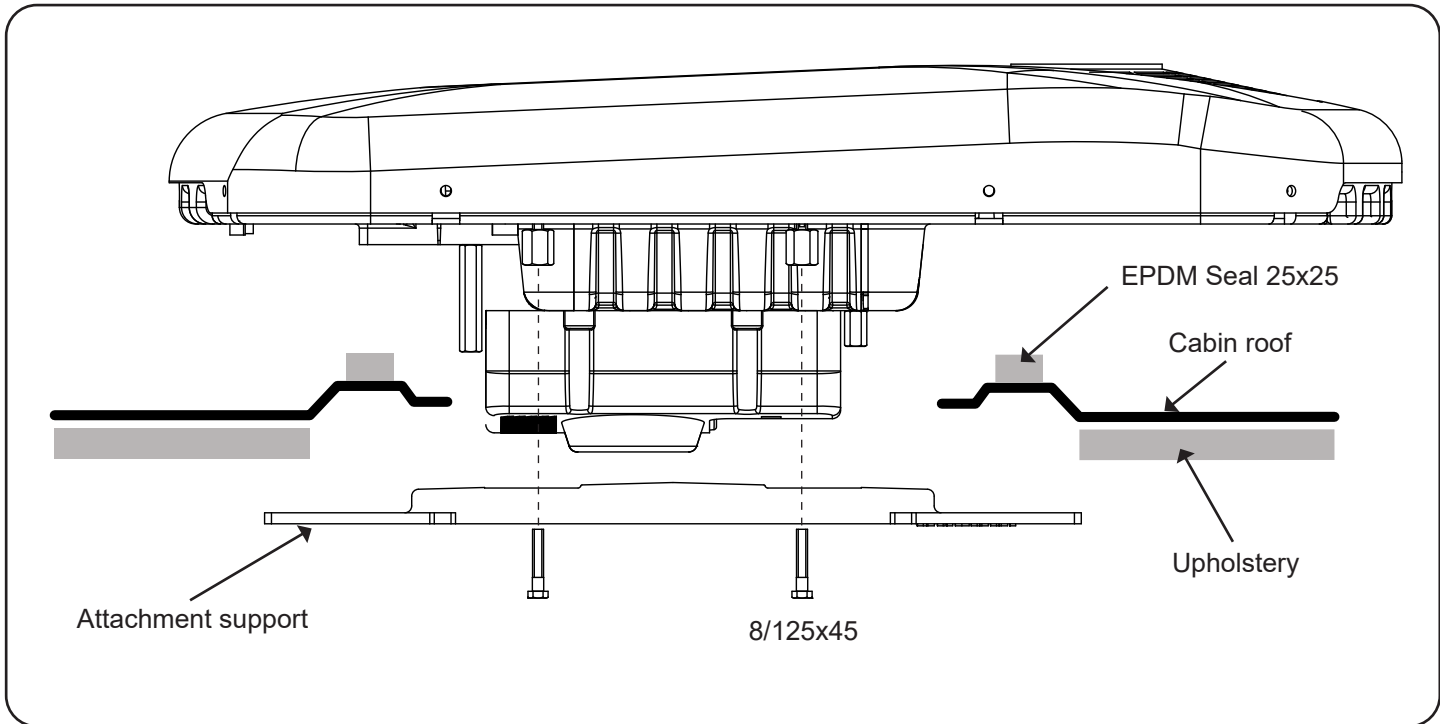

DAF XF 105 Space Cab (EURO 5 adjustable spoiler)

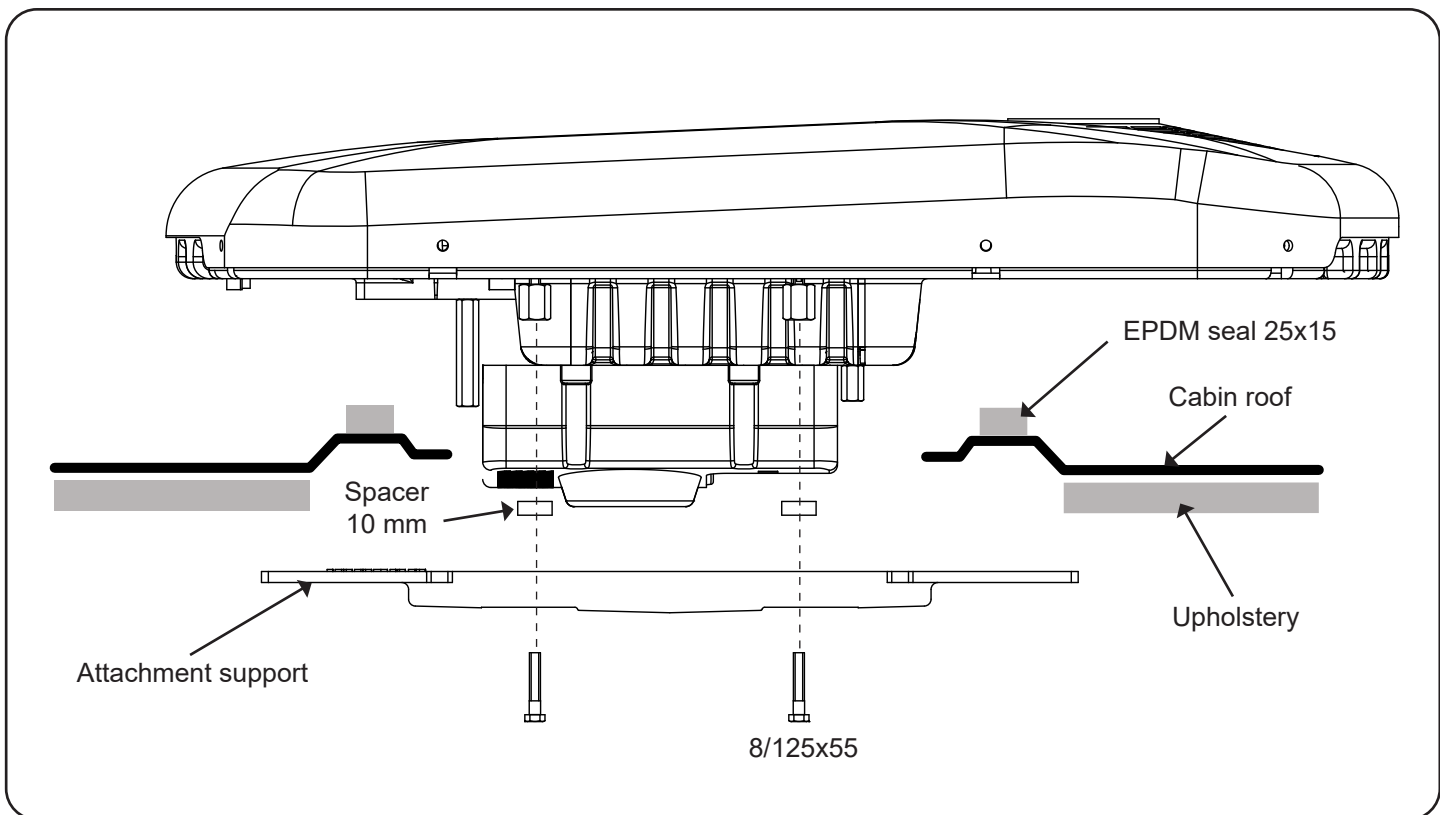

Exploded view through to the support attachment

DAF XF 105 Super Space Cab EURO 5 and EURO 6

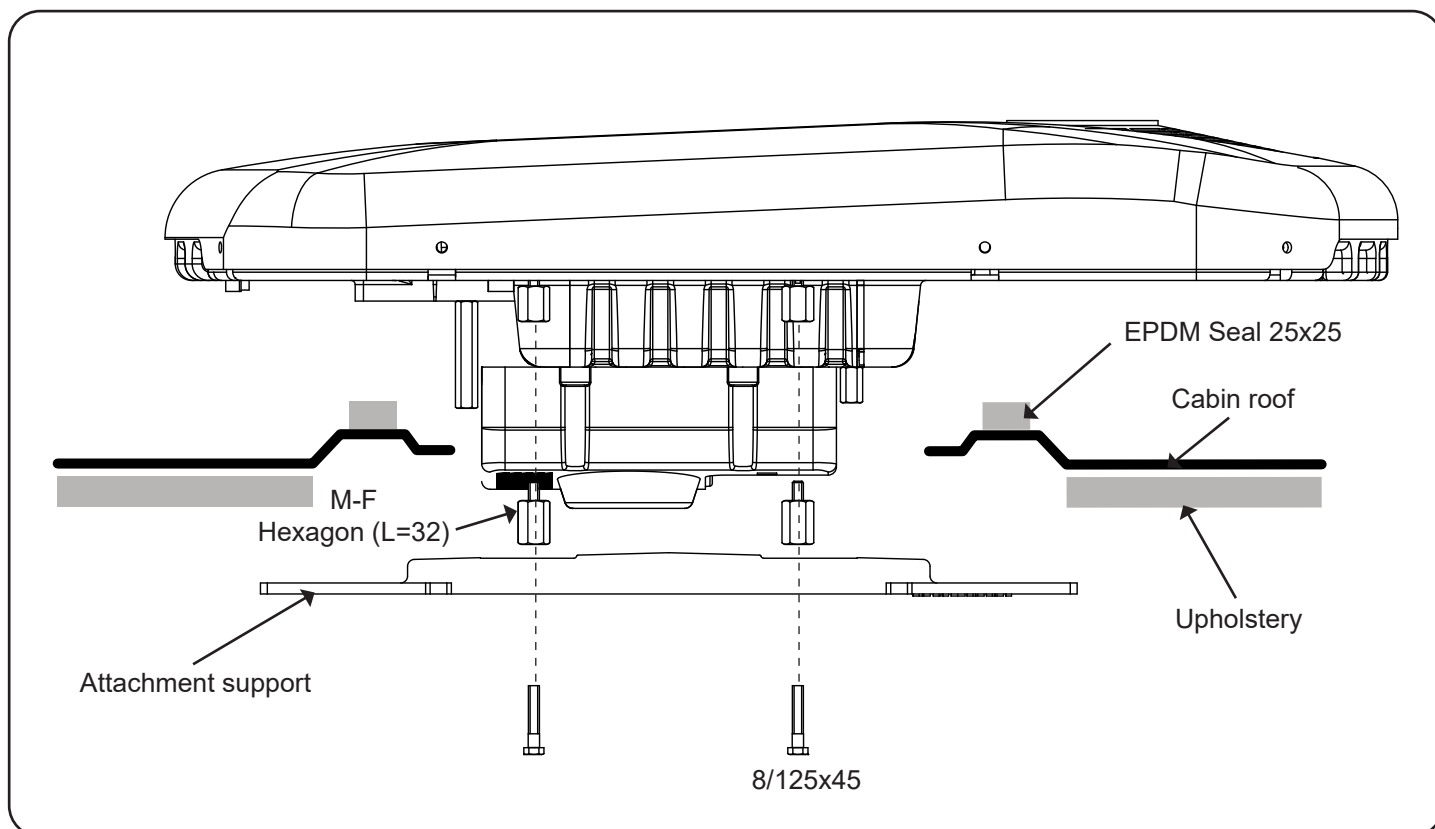

Detailed instructions on cable installation with original connection in hatch

6

Connect the unit's wire clamp to the original wire clamp in the hatch area.

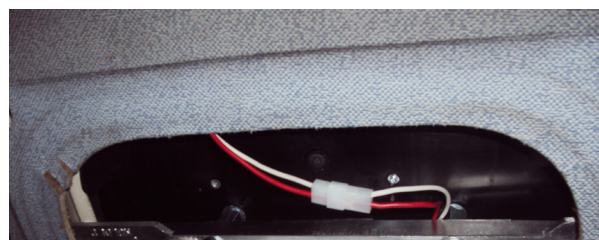

ALL MODELS EXCEPT EURO 6
Detailed instructions on the installation of power cables with access through the top right glove compartment

6 Open the top right glove compartment cover and remove the two screws from the bottom section. (A)

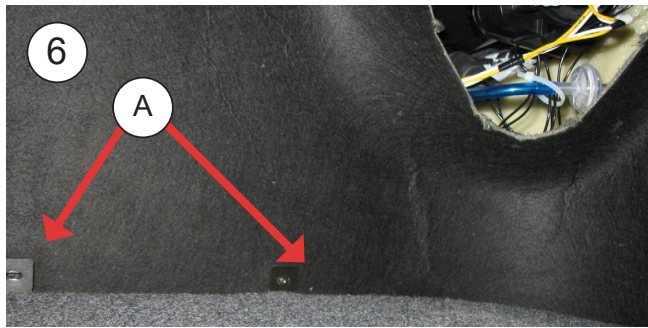

6a Slightly separate the glove box and gather in the original wiring by inserting your hand through the lower side. This cabled line is protected by a 40 amp fuse in the original central fuse boxes.



 If the existing terminal is already being used (for example, connected to a microwave), add a new terminal, similar to the existing one, from the glove compartment to the central box.

Protect the power cable with a separate 40 Amp fuse. (Set aside the 40 Amp. fuse in the central fuse box).



6b Direct the cabled line of the unit between the roof and the upholstery above the glove box and plug in both connectors. Once connected, the unit will carry out a test function; all the lights go on and off, indicating that the unit is ready.

Secure the cabled line of the unit to the aluminium support with plastic flanges, as shown in the image.



IMPORTANT
 If the cabled line is mistakenly connected with the polarity inverted, the electronic control in the unit will beep. Do not touch any buttons on the panel or remote control, as this may produce irreparable damage in the electronic system. If you hear these beeps, disconnect the unit and check the connection polarity.

ALL MODELS EXCEPT EURO 6
Detailed instructions on the installation of power cables
without access through the top right glove compartment

6 Take down the front curtain rails by releasing the screws with an Allen key.

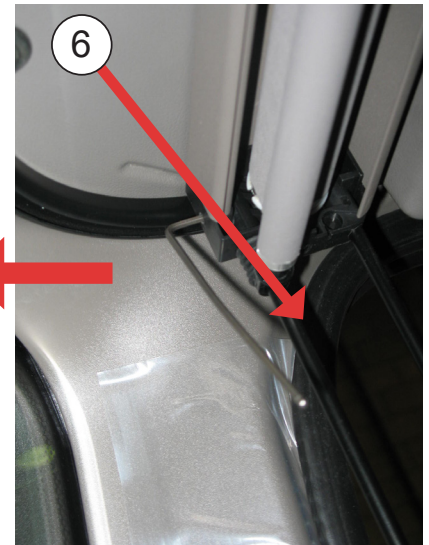
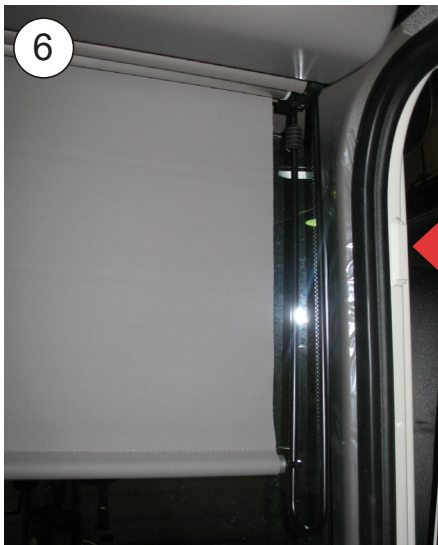

6a Remove the top glove compartment screws and tilt.



ALL MODELS EXCEPT EURO 6
Detailed instructions on the installation of power cables

7 The original power cable (A) is located in the central section; connect using the supplied cable.

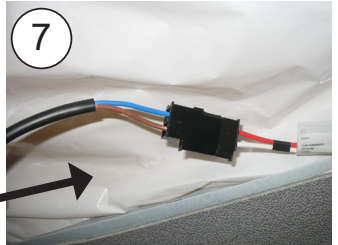
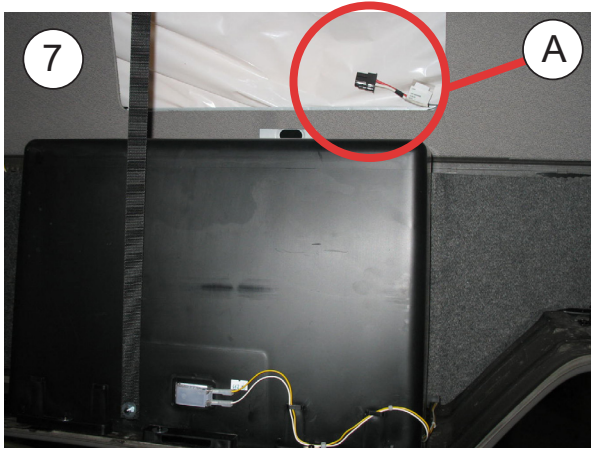

8 Open the fuse cover and position 40 A maxi-fuse in the indicated place.

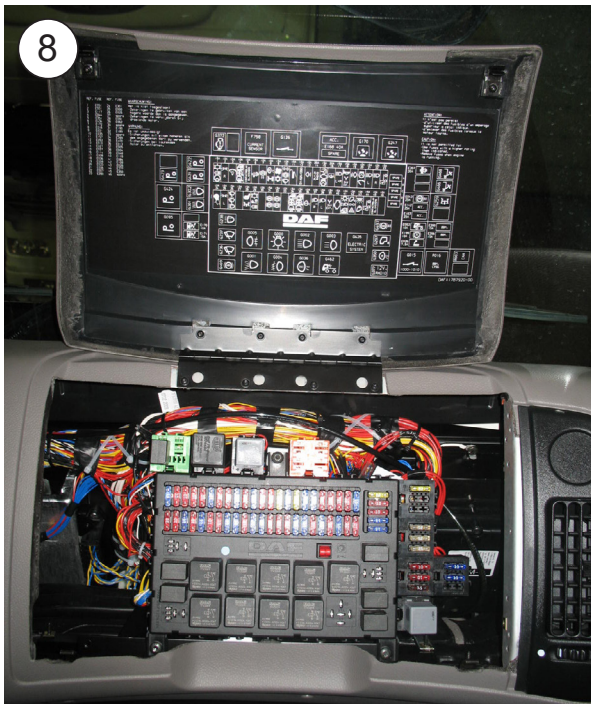

maxi-fuse 40 A

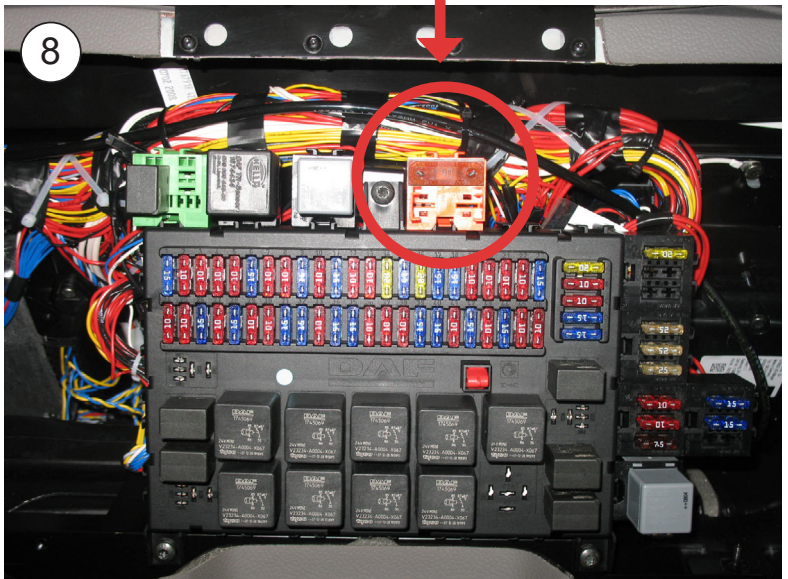

Detailed instructions on the installation of Euro 6 model cables

9 Take down the indicated covers on the inside of the cabin.



10 Remove the fuse box.



11 Pass the end of the blue wire with the supplied box along with the original wires to point A and connect.

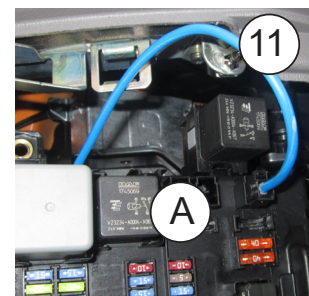
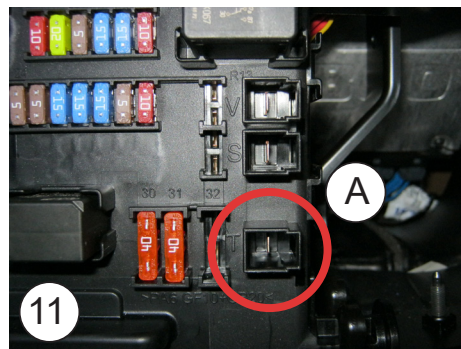
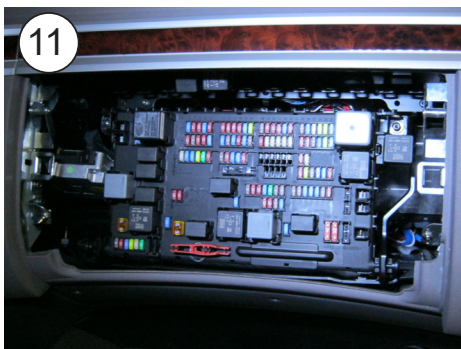

Detailed instructions on the installation of Euro 6 model cables

12 Position 25A fuse in (B).

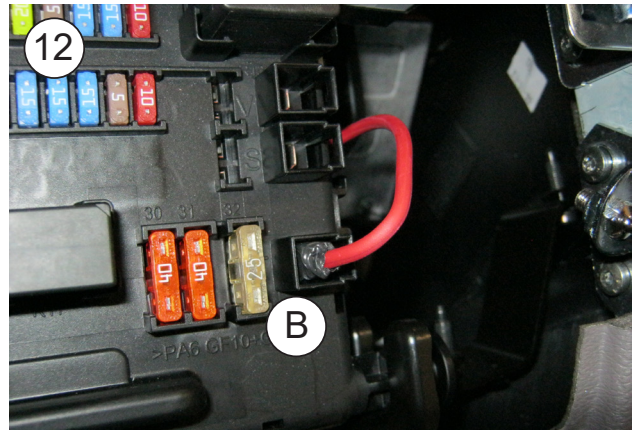

13 Pass the end of the brown wire with the supplied box along with the original wires to point C and connect.

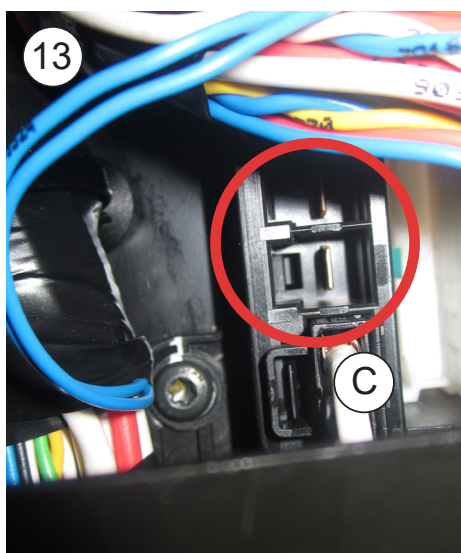
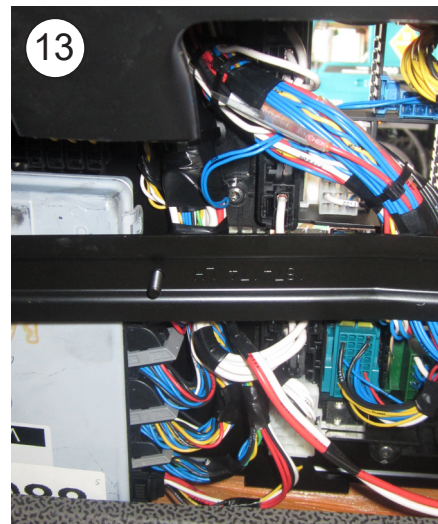

Detailed instructions on the installation of Euro 6 model cables

14 Open the top right glove compartment (D) and remove the cover (E).

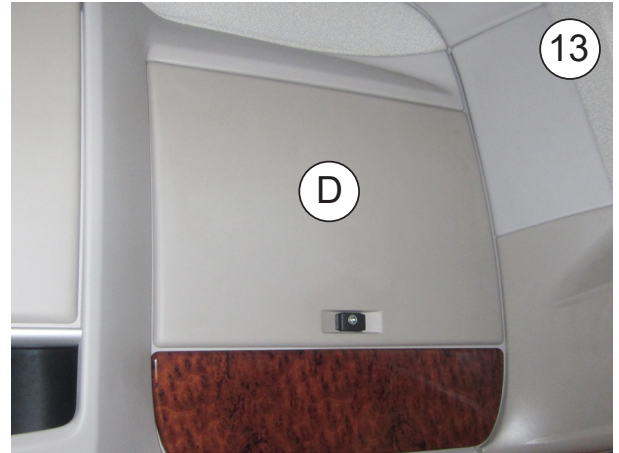
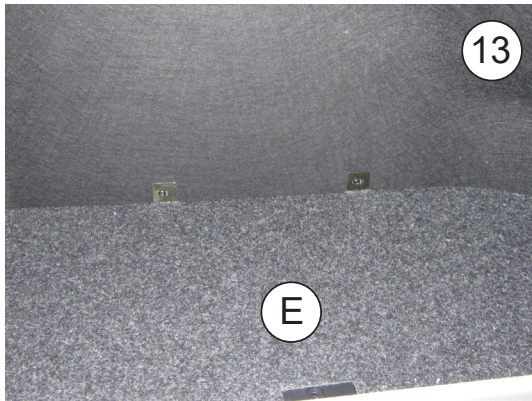

15 Insert Az and M wire through the corrugated pipe located at the bottom of the passenger side, and remove it through the end of the pipe in the top right glove compartment.

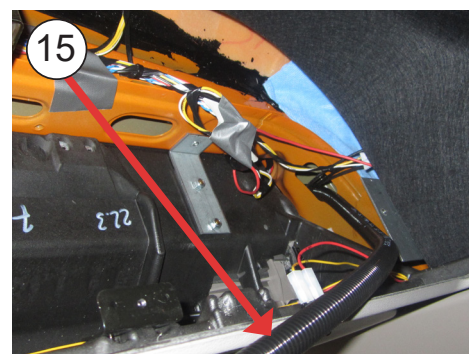
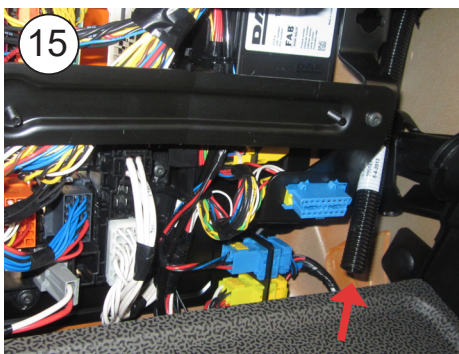

16 Secure the terminals supplied with Az and M wires and introduce in the supplied wiring box, ensuring the colours coincide.

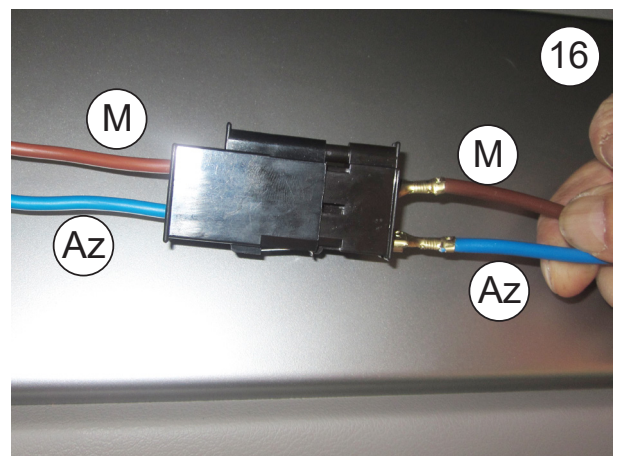

Detailed instructions on the installation of Euro 6 model cables

17

Connect the wiring boxes and run the wiring behind the original glove compartments and the upholstery through to the unit and connect.

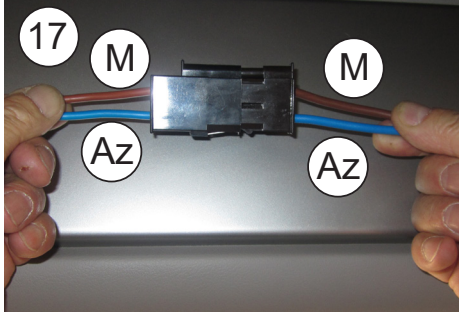

18

For DAF XF 105 Space Cab vehicles manufactured since 10/09/2012, replace the M-F M6 L78 and L36 threaded hexagons on the base of the unit with M-F M6 L68 and L26 hexagons respectively before mounting the console. See attached diagrams.

DAF XF 105 Super Space Cab EURO 5 and EURO 6

Exploded side view through to console attachment

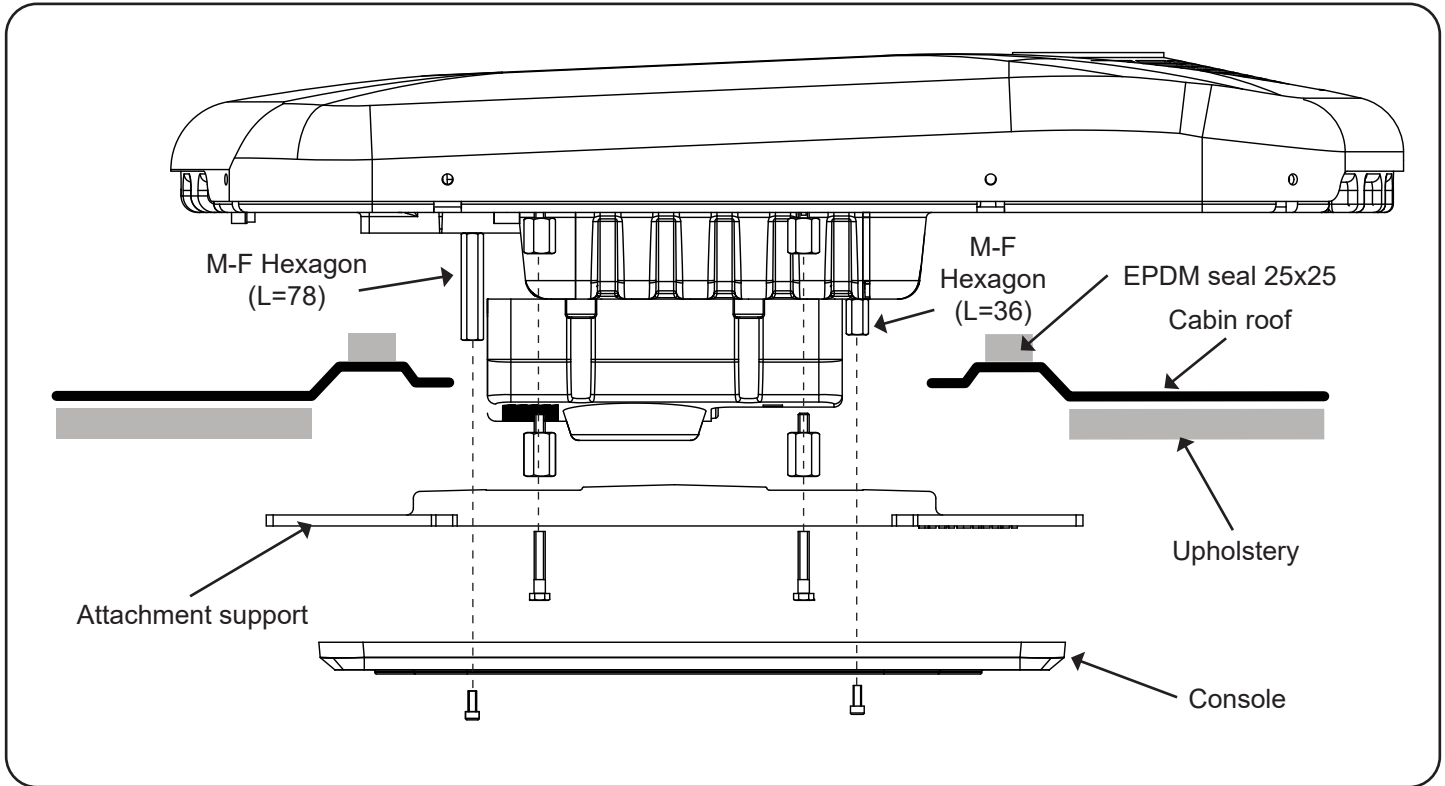

Exploded frontal view to consoles fastening

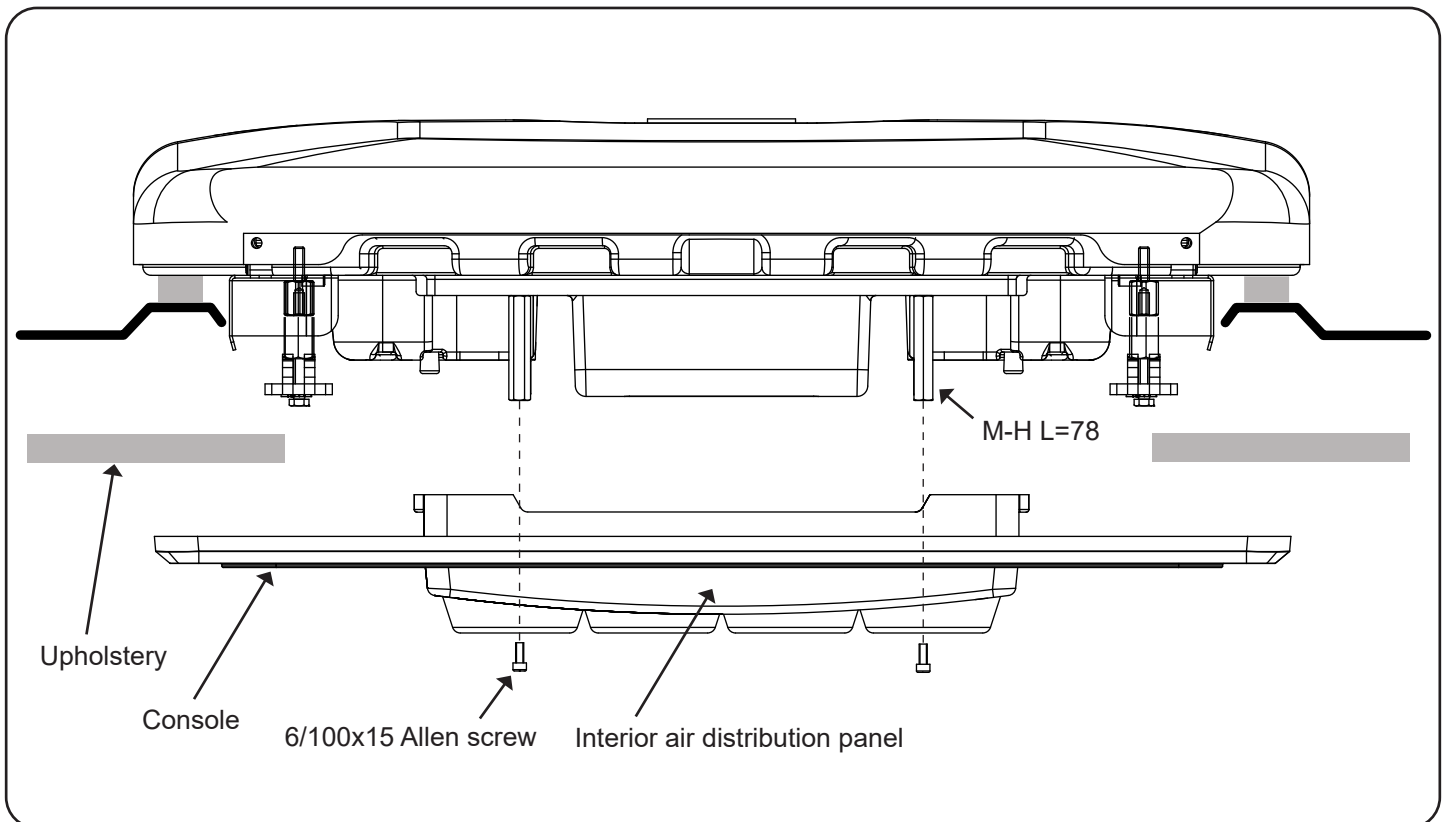

**DAF XF 105 Space Cab EURO 5 non-adjustable spoiler
DAF XF 105 Space Cab EURO 6**

Exploded side view through to console attachment

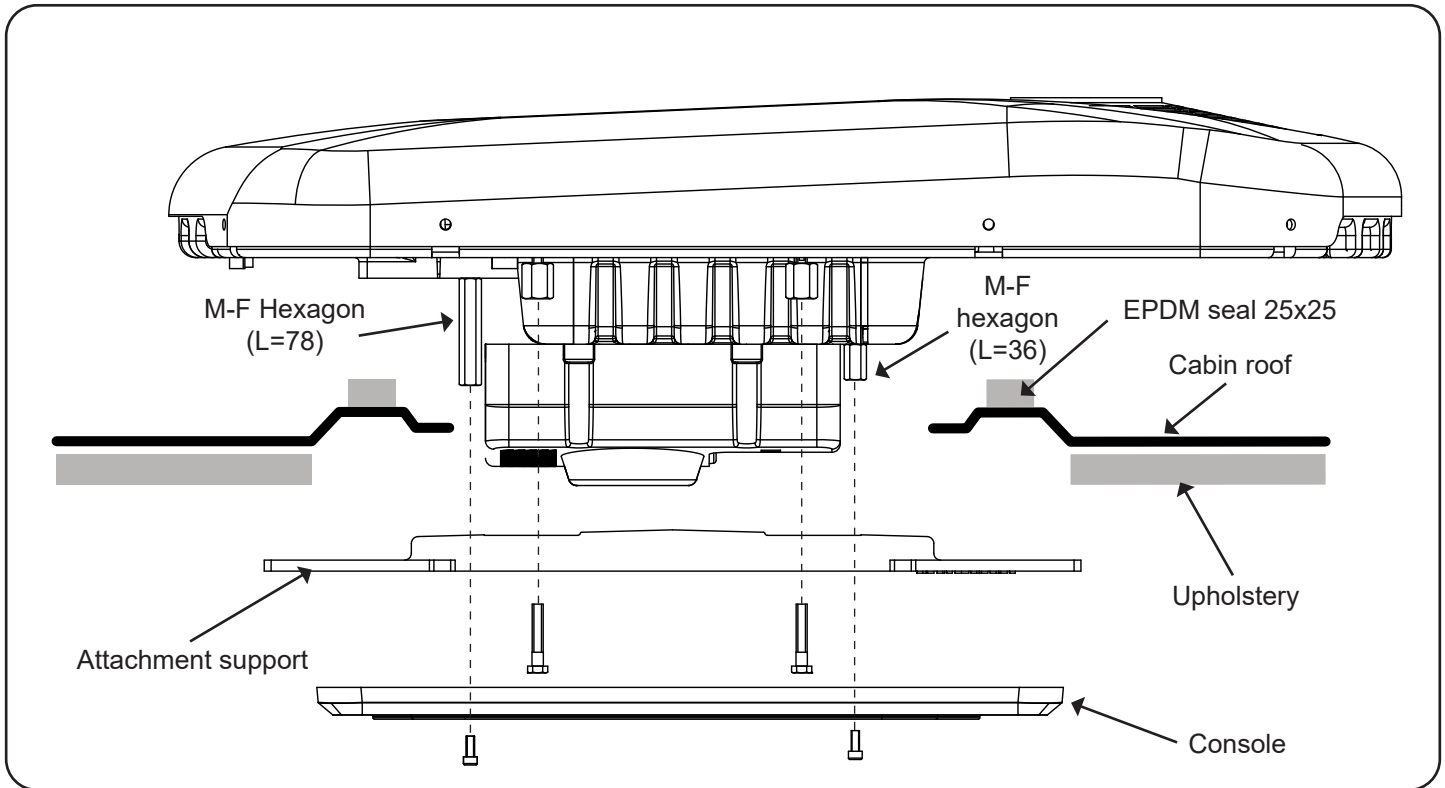

Exploded frontal view to consoles fastening

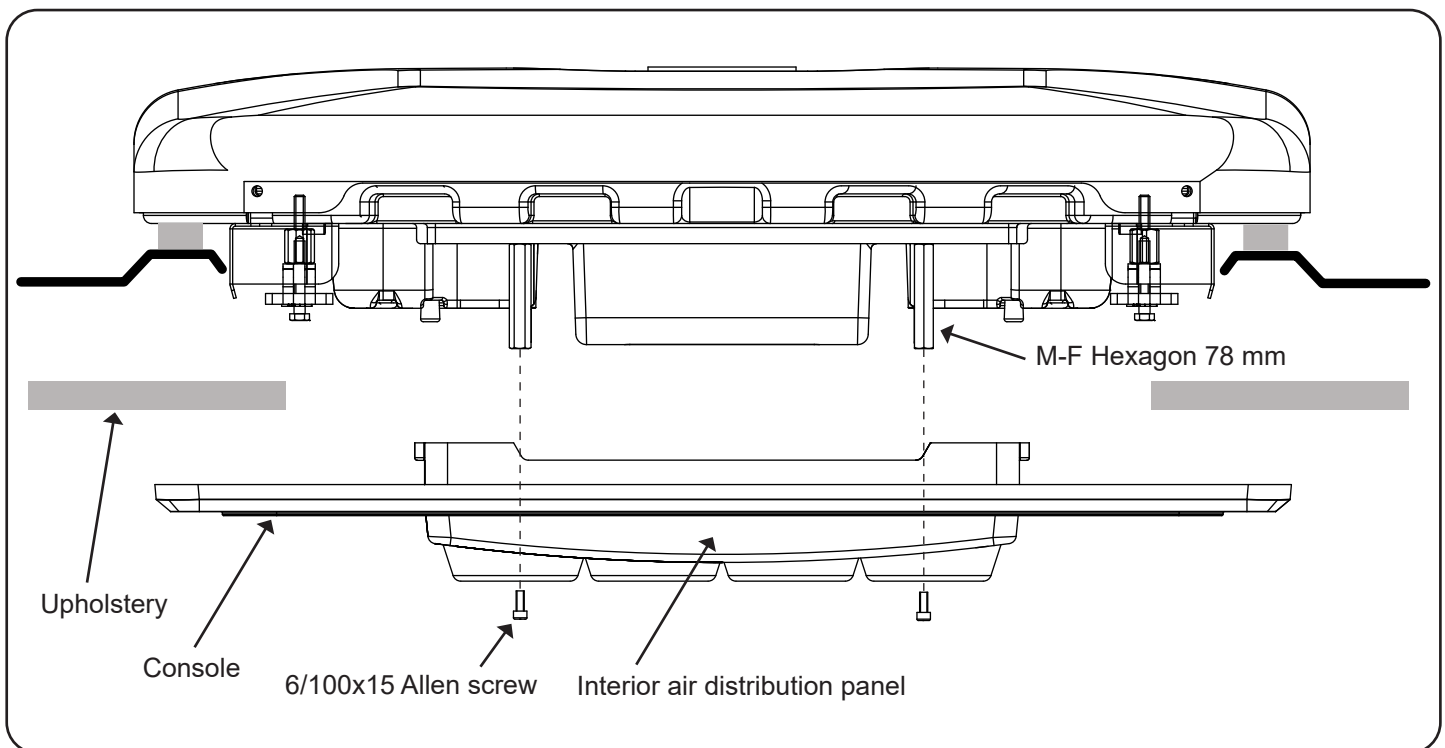

DAF XF 105 Space Cab (EURO 5 adjustable spoiler)

Exploded side view through to console attachment

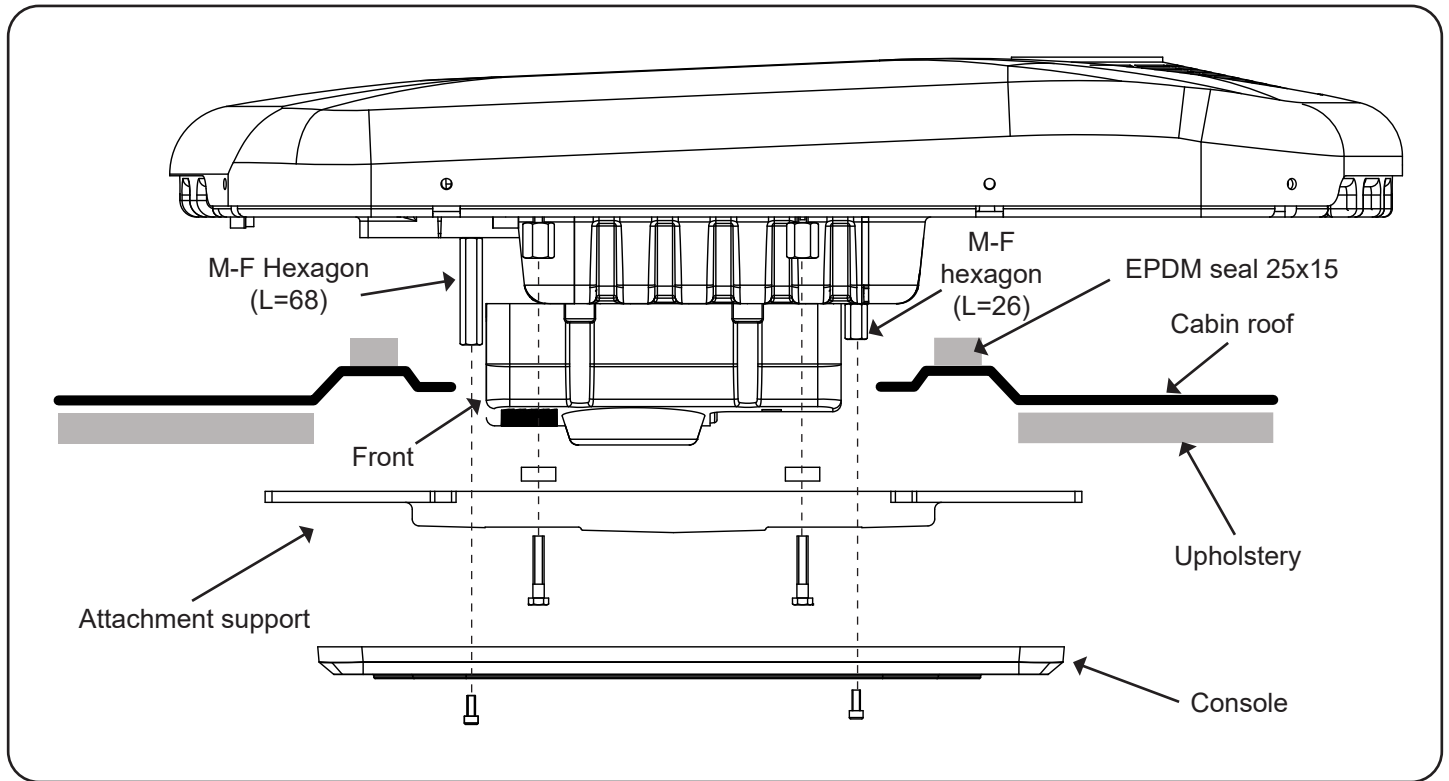

Exploded frontal view to consoles fastening

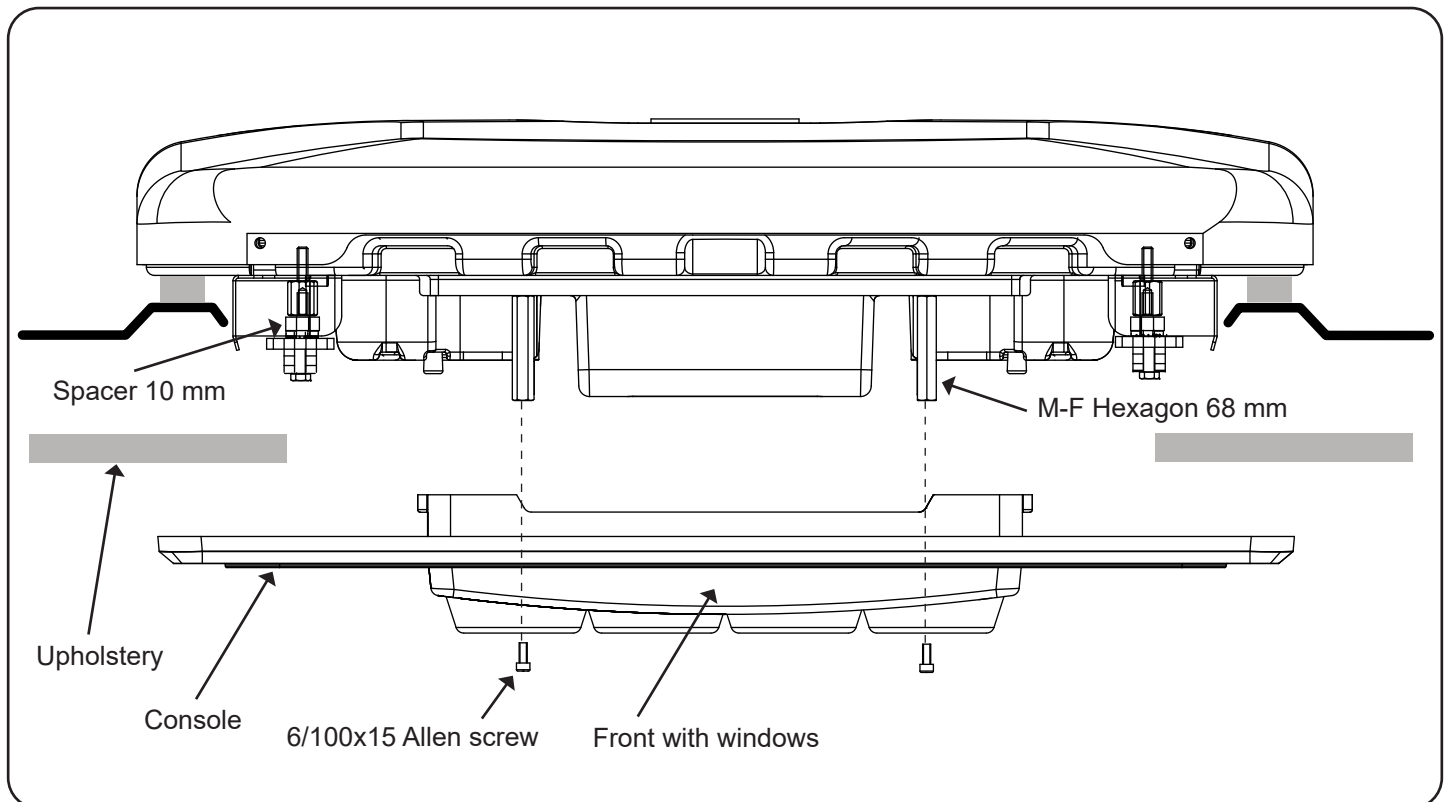

ALL MODELS

18 Return the original decorative pieces to their position.

Mount the console on F-F hexagons with (4) 6/100x15 Allen screws, positioning the shortest part of the console in the front of the cabin.



19 Cover the (4) M6/100x15 Allen screws with the M6 round plastic decorative pieces.



ALL MODELS WITH ORIGINAL CONNECTION IN HATCH Wiring Diagram

IMPORTANT NOTE!

Take care not to invert polarities when connecting the unit to the power supply; the display does not come on and the unit does not work.

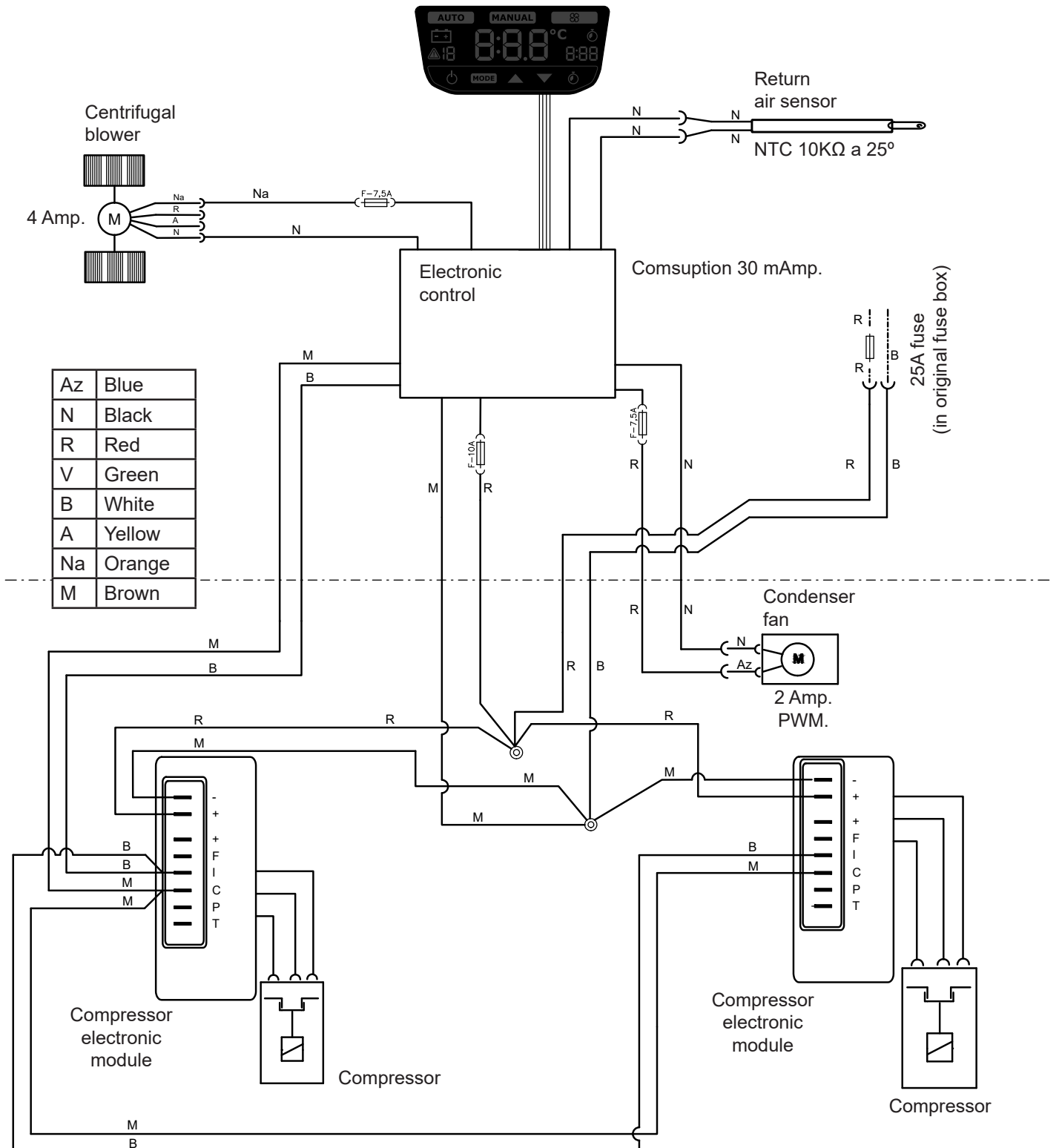

ALL EURO 5 MODELS BEHIND THE GLOVE COMPARTMENT Wiring Diagram

IMPORTANT NOTE!

Take care not to invert polarities when connecting the unit to the power supply; the display does not come on and the unit does not work.

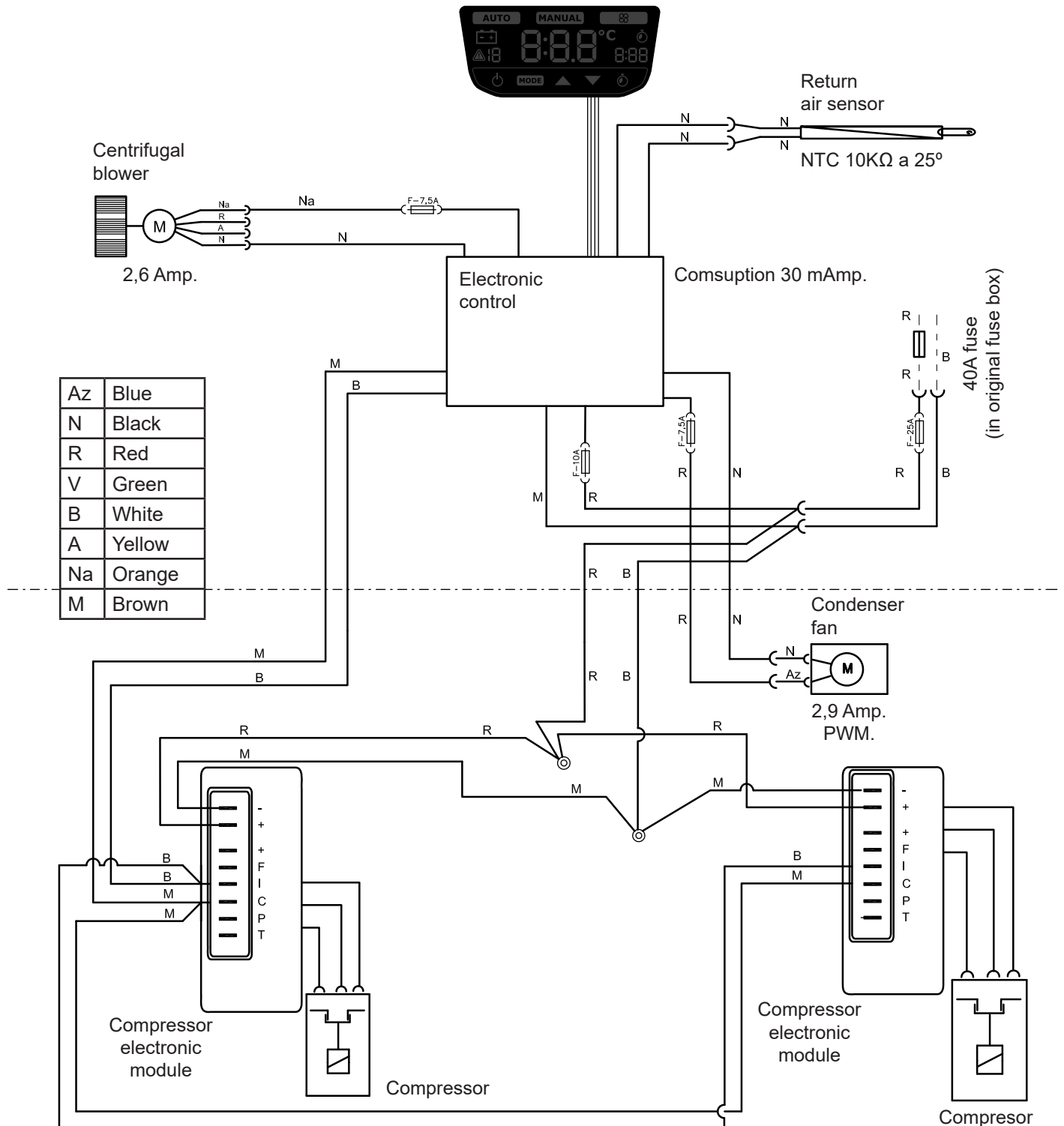

ALL MODELS EURO 6 WITHOUT ORIGINAL CONNECTION IN HATCH Wiring Diagram

IMPORTANT NOTE!

Take care not to invert polarities when connecting the unit to the power supply; the display does not come on and the unit does not work.

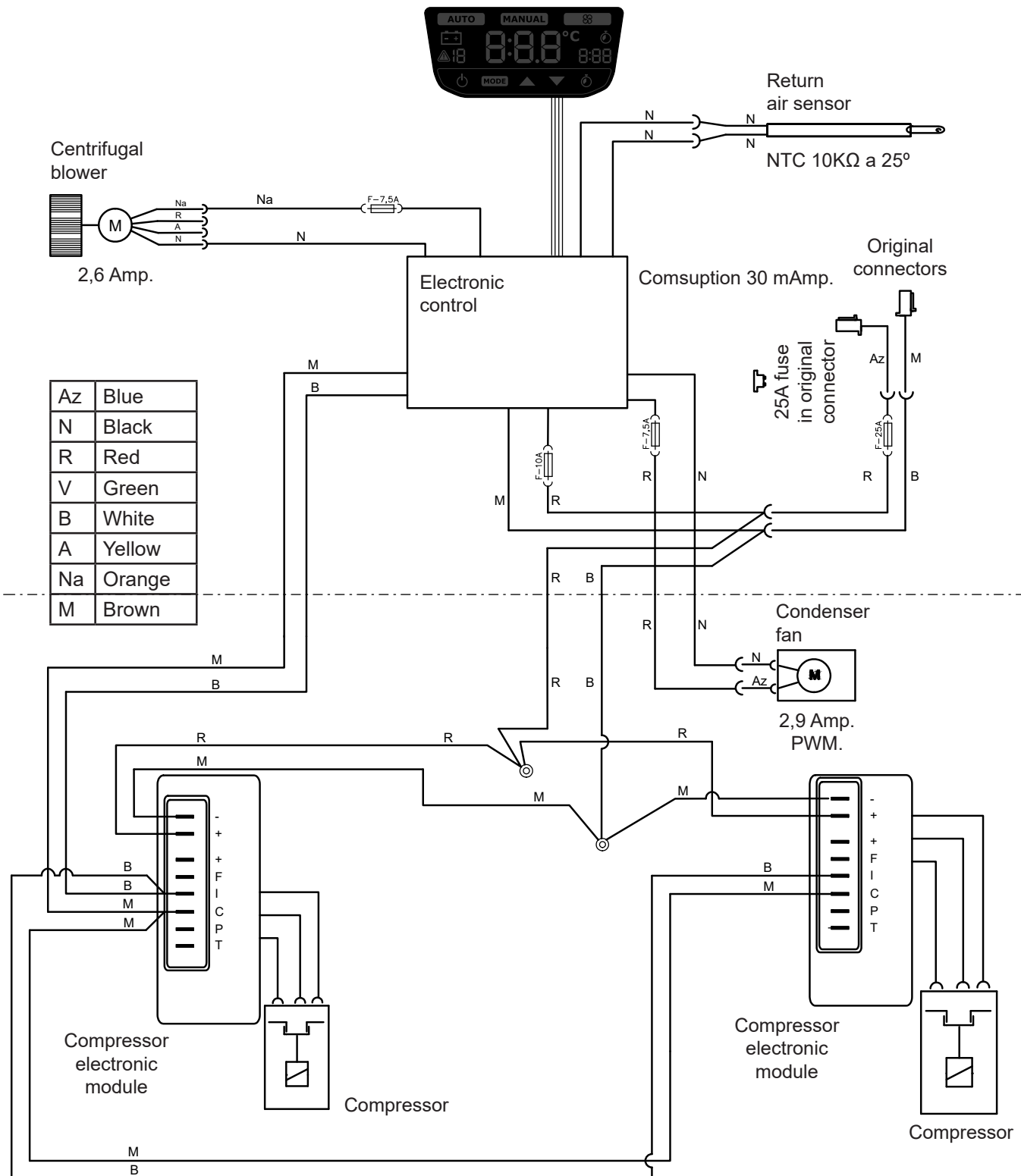

Recommandations Pour Le Montage

- Avant de commencer le montage de l'appareil, prière de lire les instructions et de les suivre attentivement.
- Utiliser les outils convenant à chaque opération.

Electricity

- Déconnecter la clé de contact.
- Déconnecter la batterie avant de commencer le montage.
- Vérifier le câblage des composants électriques et leur correcte installation.

Attention

Si pendant le montage l'équipement est incliné, il faudra attendre au moins 60 minutes avant de le mettre en marche une fois qu'il aura été remis sur sa position horizontale.

Attention

Lors de l'installation de l'appareil d'air conditionné sur le toit, il faudra protéger la partie supérieure de la cabine avec un linge ou une couverture de protection afin d'éviter les éventuelles égratignures.

Durant l'installation du **SLIMCOOL**, tenir compte du fait que normalement les cabines pourvues d'écoutille possède une structure suffisamment solide pour supporter le poids de l'appareil. Cependant, si ce n'est pas le cas et qu'il est nécessaire de découper le toit ou même si disposant d'écoutille, la structure n'est pas suffisamment rigide (si elle était en fibre, plastique, etc.) il appartiendra à l'installateur de décider s'il faut renforcer le toit pour éviter toute déformation, rupture ou voie d'eau, etc., et prendre les mesures nécessaires à cet effet.

Prendre toutes les précautions requises pour les cabines à toit haut en plastique du DAF XF 105 et n'appuyer que sur les nerfs de la cabine afin d'éviter l'affaissement de la pièce en fibre.

Outils

Jeu de clés Torx
 Jeu de clés Allen
 Clé fixe 10, 13, 14, 20
 Ciseaux
 Mètre

Documents rattachés

| | |
|-------------------------|------------|
| Instructions de montage | 1003272654 |
| Guide de l'utilisateur | 1003272655 |
| Solution des problèmes | 1003272657 |
| Liste de rechanges | 1003216944 |

Documents joints

| | |
|--------------|------------|
| Guide rapide | 1003272653 |
| Garantie | 220AA10017 |

Symbologie



Fragile





Attention aux coupures !





Risque électrique

Garantie

 L'installateur devra posséder la formation pertinente en air conditionné sur véhicules.

 **Dirna Bergstrom**, ne sera pas responsable des dommages ou des bris dérivés d'une installation ou d'une manipulation incorrecte ni des modifications réalisées sans autorisation expresse par écrit.

 **Appareil pré-chargé de gaz réfrigérant. (Ne pas manipuler le circuit de gaz réfrigérant).**

 Voir la **procédure de garantie** du produit au **Diagnostic de problèmes**.

 Voir le **Guide de l'Usager** de l'appareil pour le fonctionnement correcte de la télécommande et du tableau de commande.

 Après l'installation, vous devez fournir à l'utilisateur: **Manuel d'utilisation, garantie et diagnostic de pannes**.

**IMPORTANT :**

Ce document reprend les instructions de montage pour les modèles :

**DAF XF 105 SPACE CAB EURO 5
(SPOILER NON RÉGLABLE)****DAF XF 105 SPACE CAB EURO 5
(SPOILER RÉGLABLE)**

**DAF XF SUPER SPACE CAB
EURO 5 ET EURO 6**



EURO 5



EURO 6

**DAF XF SPACE CAB
EURO 6**



DAF XF 105 Space Cab EURO 5 et EURO 6

1

Démonter le couvercle de l'écouille et les éléments de fixation et remettre ces derniers au client (*).

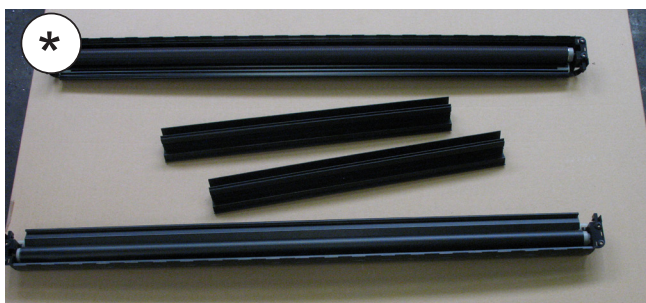

1a

Retirer les résidus adhérents au plafond avant de coller le joint EPDM.

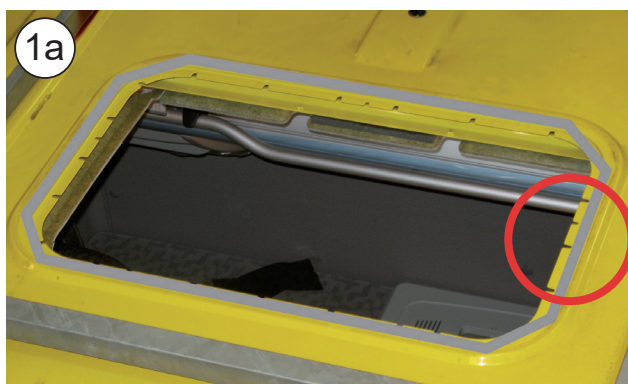

DAF XF 105 Super Space Cab EURO 5 et EURO 6

1b Démontez les enjoliveurs latéraux (*) en les tirant et en les déplaçant vers la partie arrière de la cabine.



1c Démontez l'enjoliveur avant (*) en le tirant vers le bas et déconnecter les bornes des lumières.

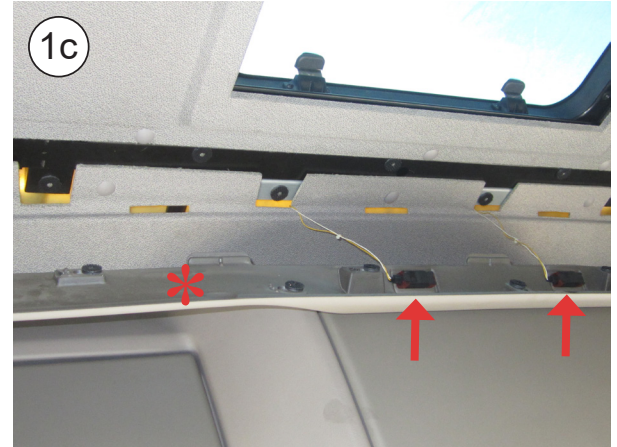

1d Démontez les goupilles de fixation de la tapiserie de la partie avant depuis le rail du rideau avec un outil spécial.



DAF XF 105 Super Space Cab EURO 5 et EURO 6
1e

En déplaçant la tapissérie vers le bas, démonter les vis frontales de fixation du rail du rideau de l'écoutille et le démonter.

**1f**

Démonter le cadre intérieur de l'écoutille (*).

**1g**

Démonter l'écoutille en retirant les vis de fixation et en débranchant le connecteur.

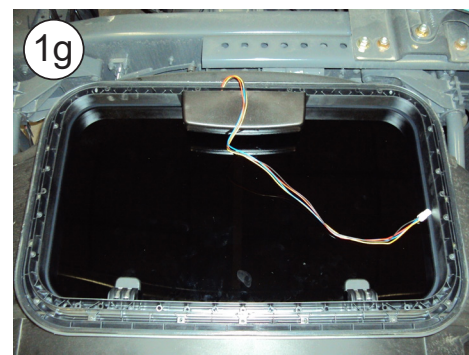
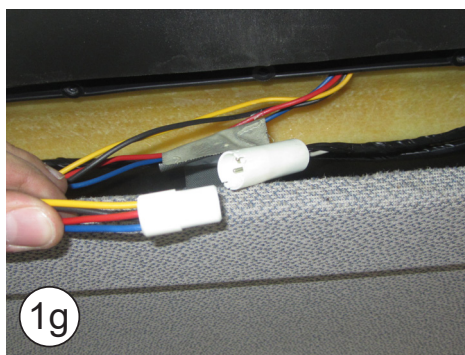

TOUS LES MODÈLES

2

Collez le joint EPDM autour du creux de l'écouille (suivre le détail pour couper les bords fins d'union du joint).

- DAF XF 105 SPACE CAB. EURO 5 SPOILER NON AJUSTABLE - joint 25 x 25.
- DAF XF 105 SPACE CAB. EURO 5 SPOILER AJUSTABLE - joint 25 x 15.
- DAF XF 105 SUPER SPACE CAB. EURO 5 ET EURO 6 - joint 25 x 25.
- DAF XF SPACE CAB EURO 6 - joint 25 x 25.



COMMENT COUPER LE JOINT EPDM POUR ÉVITER LA FILTRATION D'EAU DANS LA CABINE

- A-** Coller le joint et garder 100 mm de papier protecteur de chaque côté.
- B-** Retirer les deux pièces de papier.
- C-** Collez en exerçant une pression sur les deux extrémités.

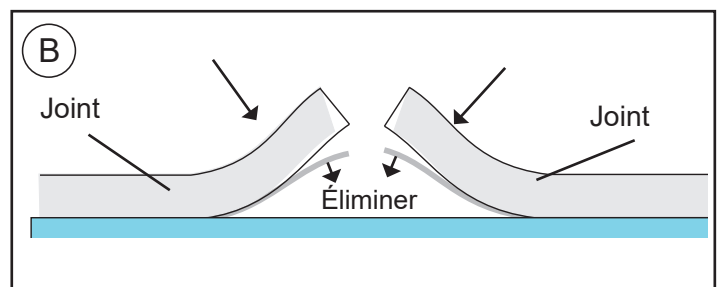
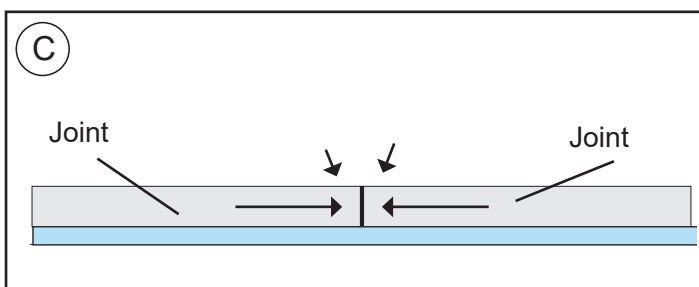
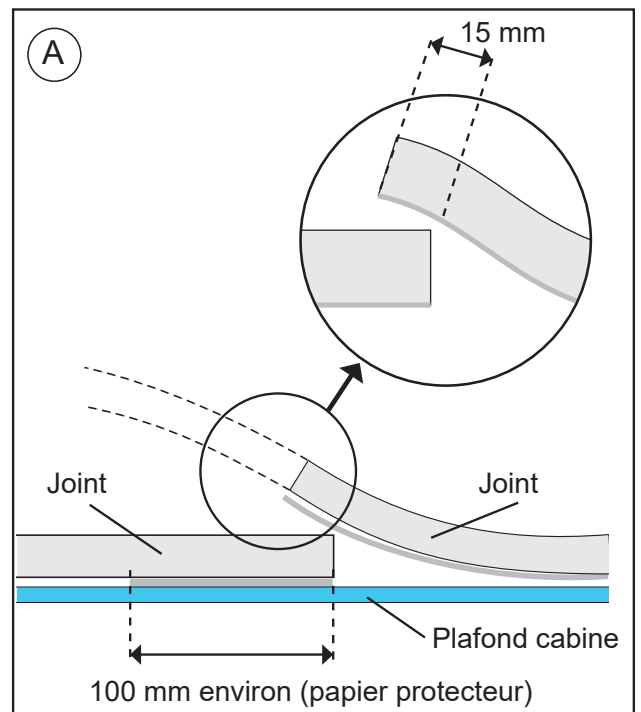

UNIQUEMENT POUR LES MODÈLES : DAF XF 105 Super Space Cab EURO 5 et EURO 6

2a

Placer l'équipement **SLIMCOOL** sur la position verticale, desserrer les vis des centreurs uniquement pour permettre leur déplacement. Les déplacer ensuite vers la partie arrière de l'équipement, jusqu'à ce que les vis atteignent les glissières des centreurs. Ensuite, serrez à nouveau les vis.

PARTIE AVANT DE L'ÉQUIPEMENT

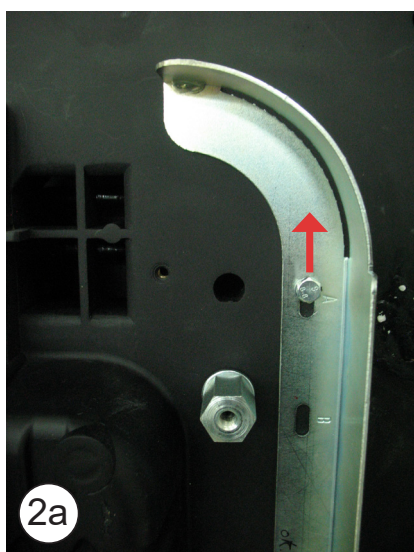
**2b**

Visser (4) hexagones M8x32 sur les hexagones de la base et serrer contre ces derniers en appliquant un contre-écrou (voir schéma page 65).



TOUS LES MODÈLES

3

EXTÉRIEUR CABINE :

Placer le **SLIMCOOL** dans le creux de l'écouille en emboîtant les centres dans ce dernier.

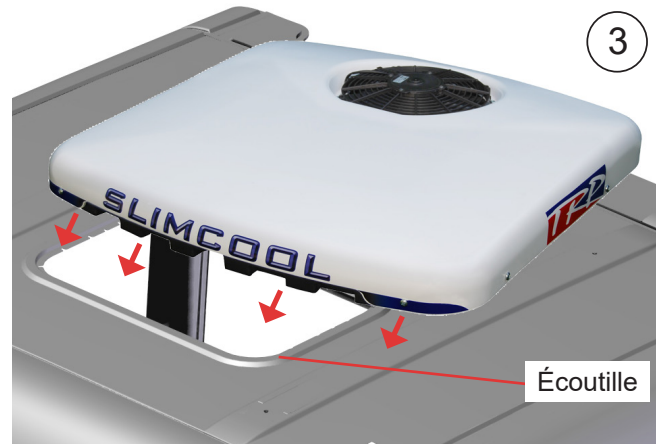

Attention! Avant de placer l'équipement sur le creux de l'écouille, vérifier que les sorties d'écoulement ne soient pas bouchées par le joint EPDM.

DAF XF 105 Space Cab Euro 5 spoiler non ajustable
DAF XF 105 Super Space Cab EURO 5 et EURO 6

4

Introduire les supports de fixation sous la tapisserie et fixer aux hexagones avec (4) vis 8/125x45, (4) rondelles plates à surface large Ø 8 et (4) rondelles grower Ø 8. Pour fixer l'équipement, il est nécessaire de serrer jusqu'à ce que les supports atteignent les hexagones.



DAF XF 105 Space Cab (depuis date fabrication véhicule : 10/09/2012)

5

Placer (2) supports de fixation tel que cela est indiqué sur le schéma, placer (4) séparateurs $\varnothing 25 \times 9 \times 10$; (4) vis M8/125x55 et serrer jusqu'à atteindre la limite (voir schéma page 64).

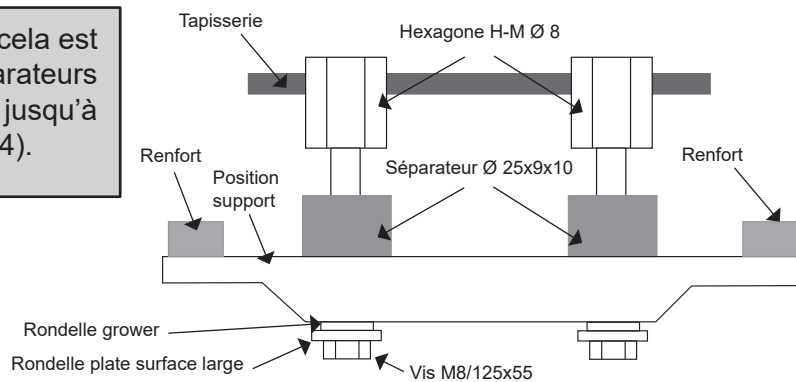

Vue décomposée jusqu'à la fixation des supports

DAF XF 105 Space Cab Euro 6
DAF XF 105 Space Cab Euro 5 spoiler non ajustable

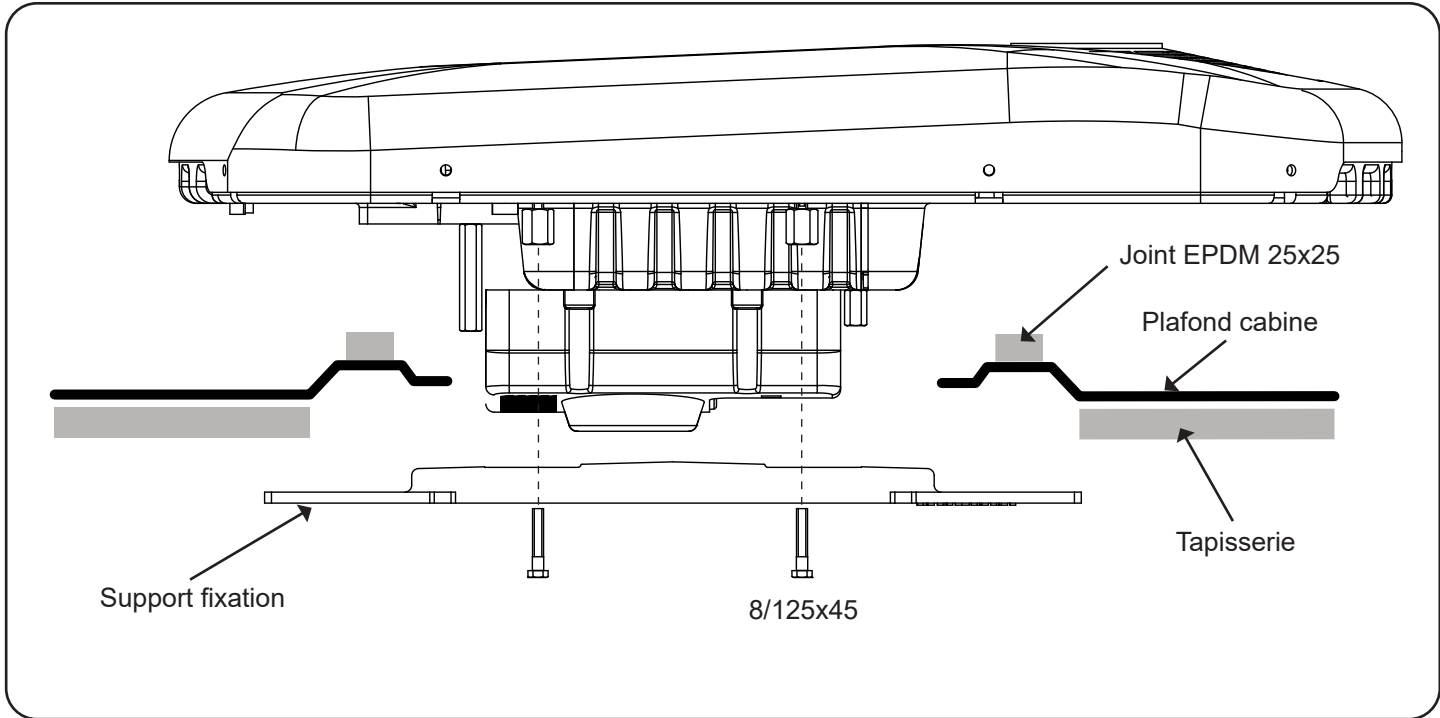

DAF XF 105 Space Cab EURO 5 spoiler ajustable

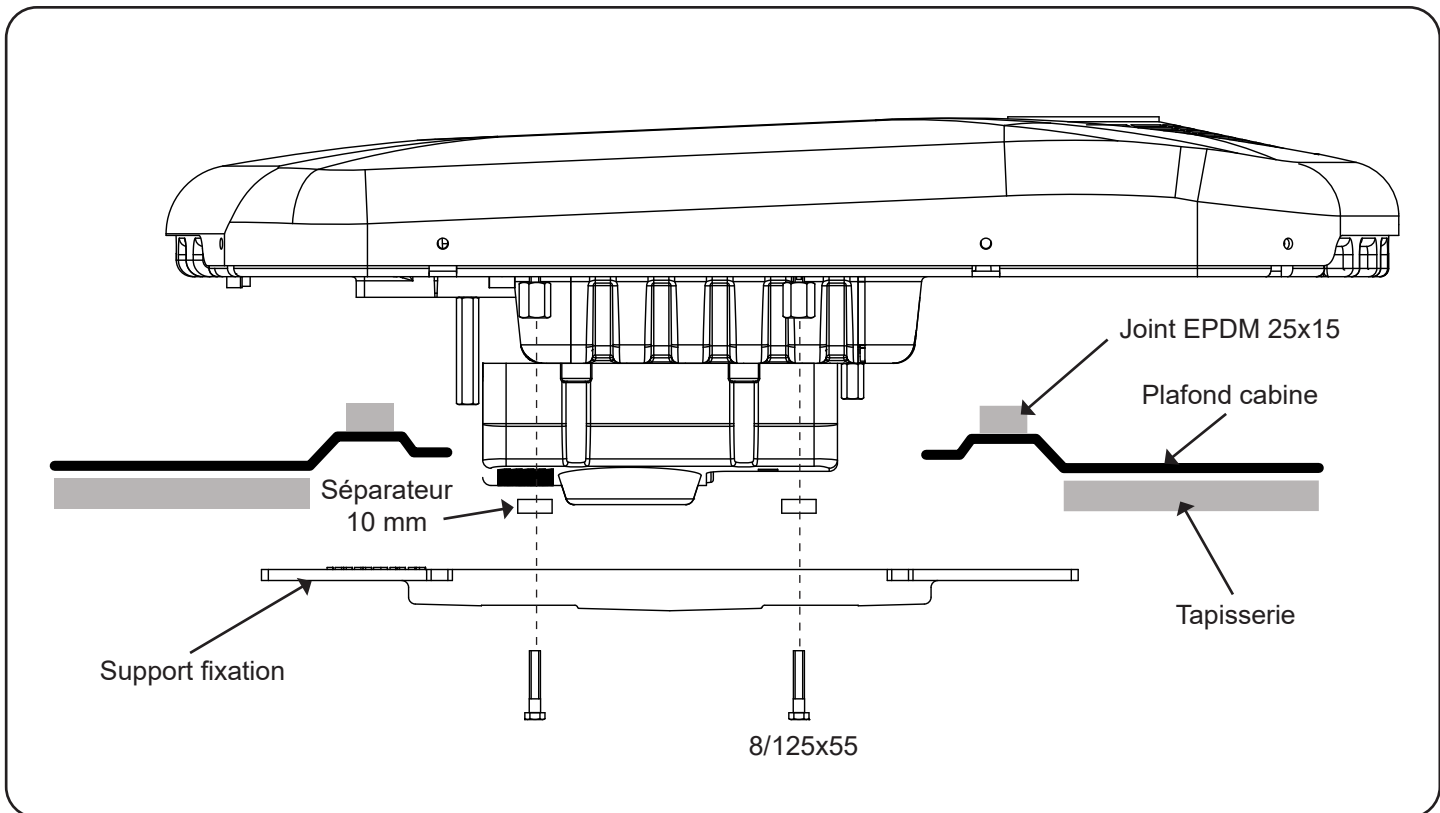

Vue décomposée jusqu'à la fixation des supports

DAF XF 105 Super Space Cab EURO 5 et EURO 6

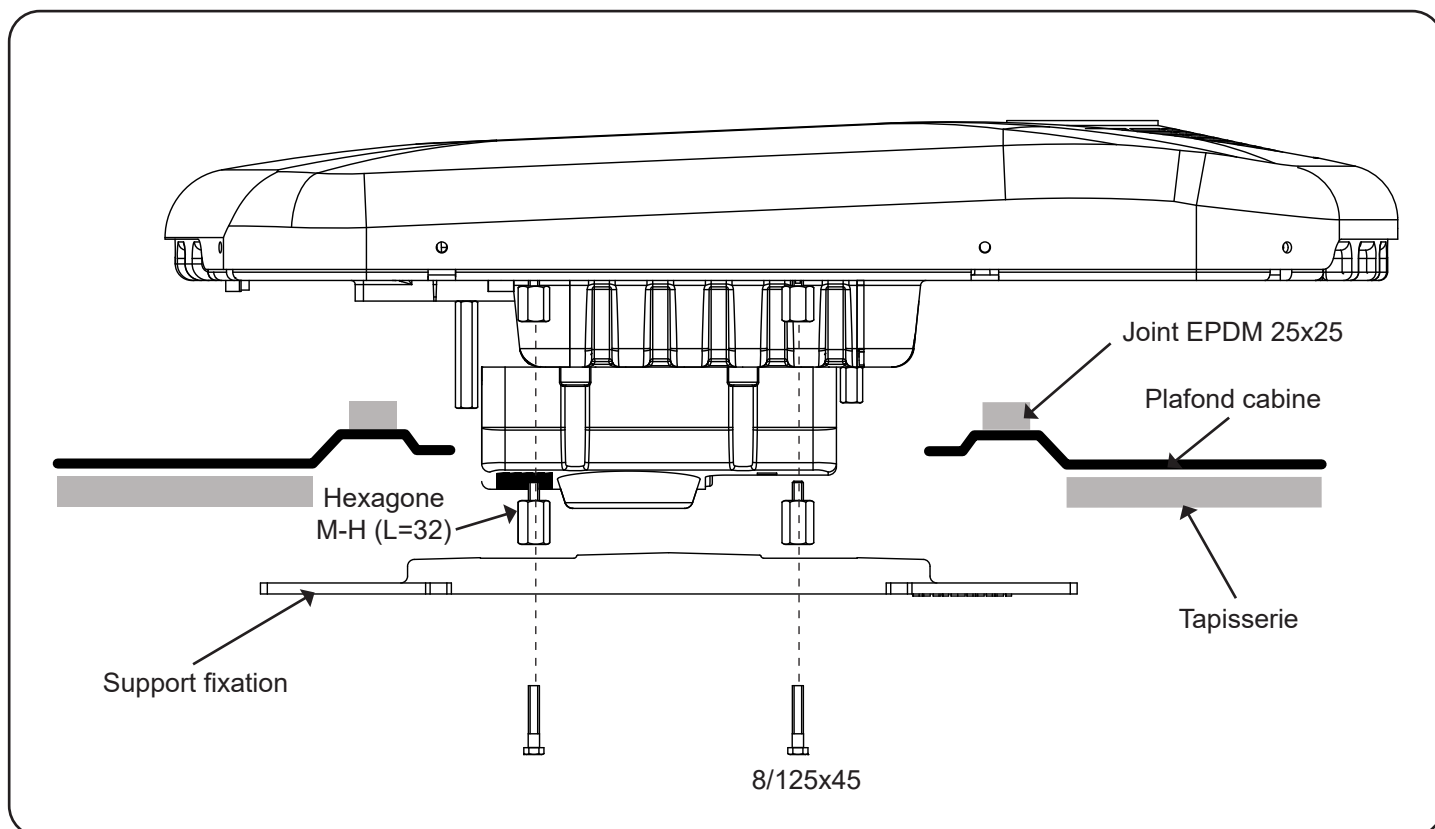

Instructions détaillées sur la connexion du câblage avec prise originale dans écouteille

6

Connecter la borne de l'équipement à la borne originale placée dans l'entourage de l'écouteille.

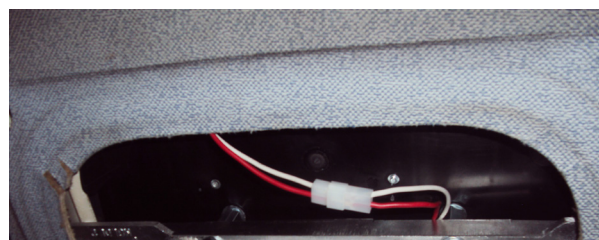

TOUS LES MODÈLES SAUF EURO 6

Instructions détaillées sur l'installation du câblage d'alimentation avec accès par la boîte à gants supérieure droite

6

Ouvrez le couvercle de la boîte à gants supérieure droite et retirez les deux vis du côté inférieur (A)

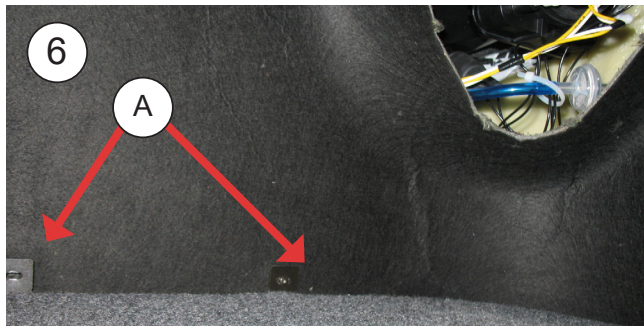
**6a**

Séparez légèrement la boîte à gants et introduisez la main à travers le côté inférieur pour récupérer le câblage d'origine. Cette ligne câblée est protégée par un fusible de 40A présent dans les boîtes à fusibles centrales d'origine.

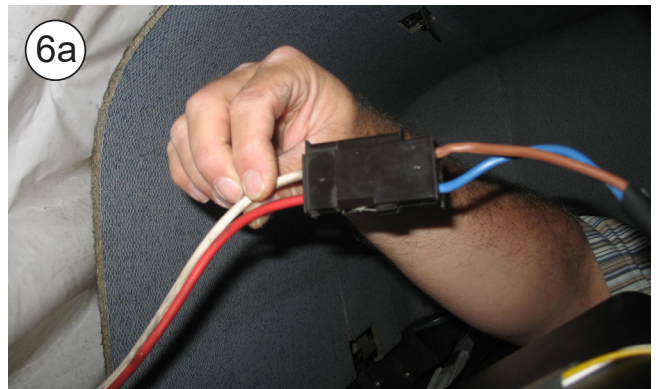

Si le connecteur du câblage existant est déjà utilisé (par exemple, connecté à un four micro-ondes), ajoutez un nouveau connecteur de câblage, semblable à celui qui existe dans la boîte, depuis la boîte à gants jusqu'à la boîte centrale.

Protéger le câble d'alimentation de courant avec un nouveau fusible séparé de 40A (réserver le fusible de 40A dans la boîte à fusibles centrale).

**6b**

Dirigez la ligne câblée de l'unité entre le plafond et la tapisserie par-dessus la boîte à gants et branchez les deux connecteurs. Une fois reliés, l'unité effectuera une fonction de vérification. Toutes les lumières s'allumeront et s'éteindront: cela veut dire que l'unité est prête.

Fixez la ligne câblée de l'unité au support en aluminium, tel que cela est indiqué sur l'image, en utilisant des brides en plastique.

**IMPORTANT**

Si la ligne câblée est connectée par erreur en inversant la polarité, le contrôle électronique de l'unité émettra des sifflements discontinus. Aucune touche du panneau ni de la télécommande de l'équipement ne doit être sélectionnée, parce que cela pourrait causer des dommages irréparables sur le système électronique. Lorsque ces sifflements sont déclenchés, il faut déconnecter l'équipement et vérifier la polarité de la connexion.

TOUS LES MODÈLES SAUF EURO 6
Instructions détaillées sur l'installation du câblage d'alimentation
sans accès par la boîte à gants supérieure droite

6

Démonter les barres de déplacement des rideaux de la partie frontale en desserrant les vis avec une clé allen.

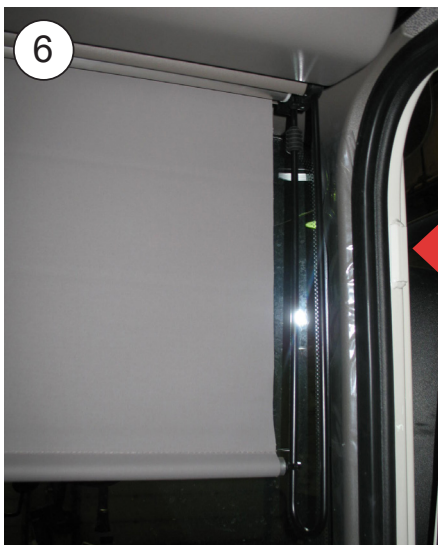
**6a**

Démonter les vis supérieures des boîtes à gants et basculer ces dernières.

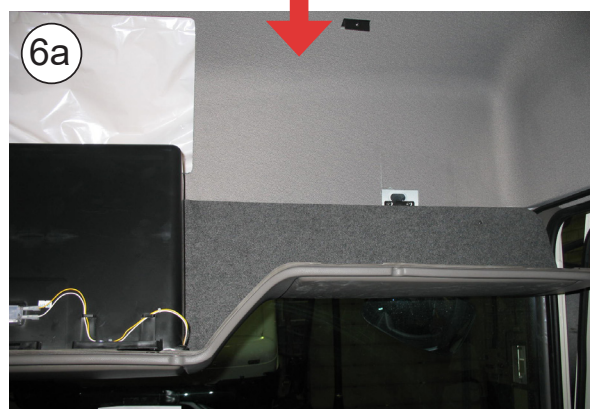

TOUS LES MODÈLES SAUF EURO 6

Instructions détaillées sur l'installation du câblage d'alimentation

7

Le câble d'origine d'alimentation (A) est situé sur la partie centrale ; connectez-le au câble fourni.

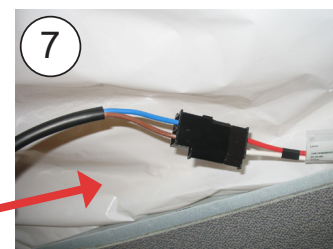
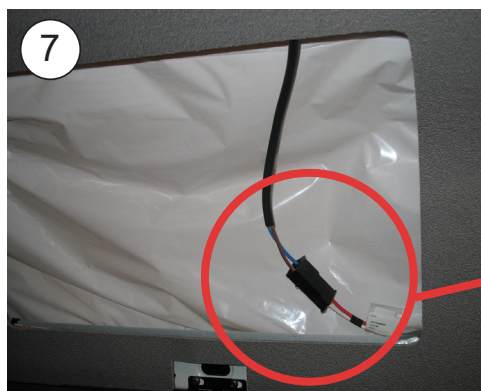
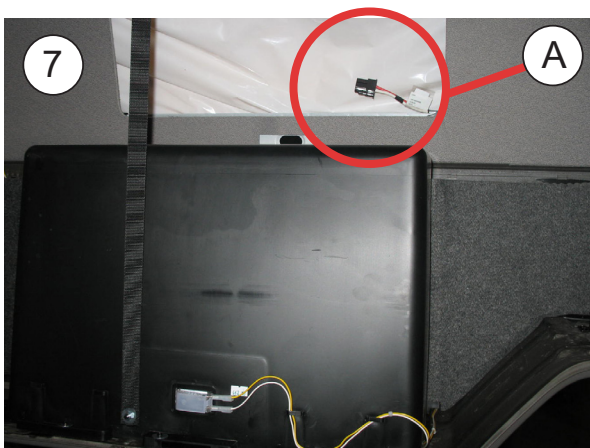

8

Ouvrir le couvercle des fusibles et placer un maxi-fusible de 40A au lieu de celui indiqué.



Maxi-fusible 40 A

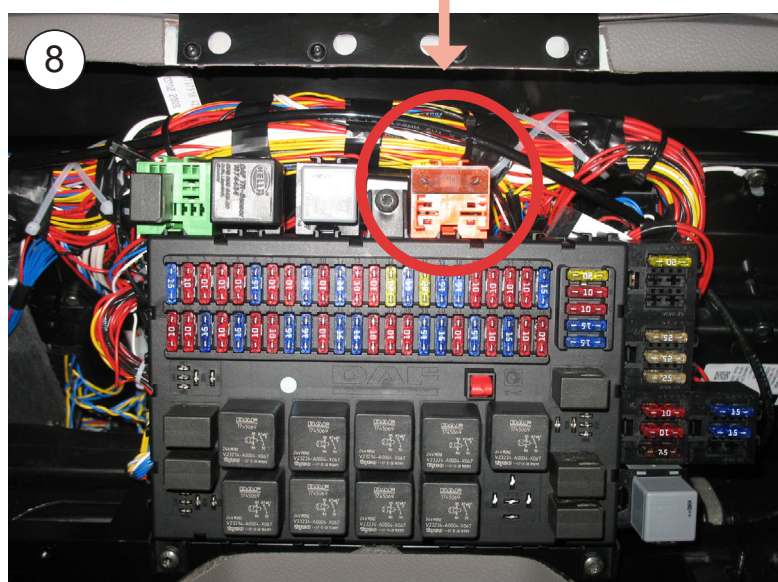
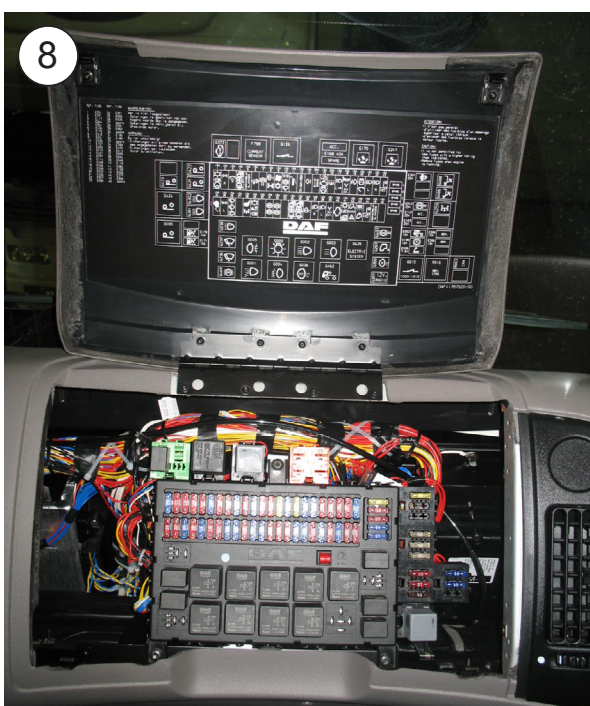

Instructions détaillées sur l'installation du câblage modèle Euro 6

9

À l'intérieur de la cabine, démonter les couvercles indiqués.

**10**

Démonter la boîte à fusibles.

**11**

Passer l'extrémité du câble bleu avec boîte fourni en accompagnant les câbles d'origine jusqu'au point A et connecter.

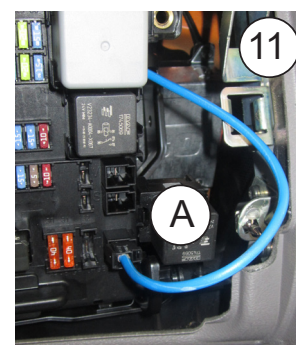
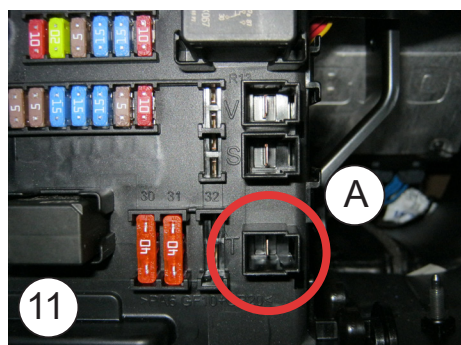
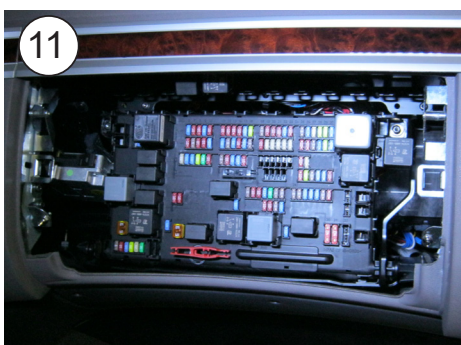
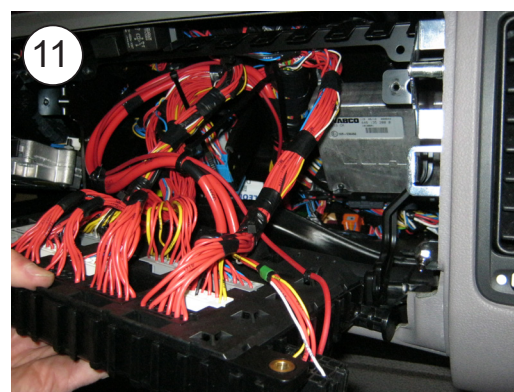

Instructions détaillées sur l'installation du câblage Modèle Euro 6

12

Placer un fusible de 25A sur (B).

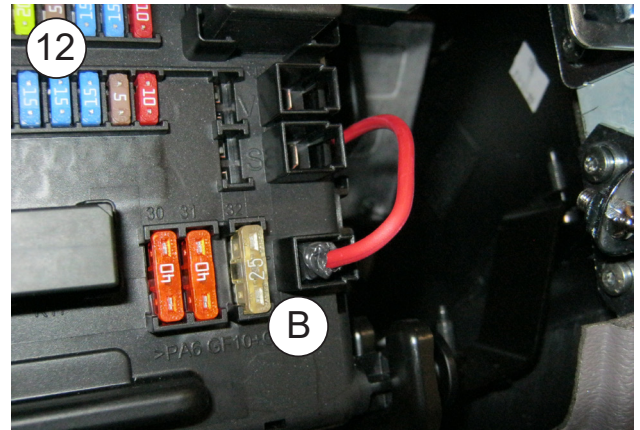
**13**

Passer l'extrémité du câble marron avec boîte fourni en accompagnant les câbles d'origine jusqu'au point C et connecter.

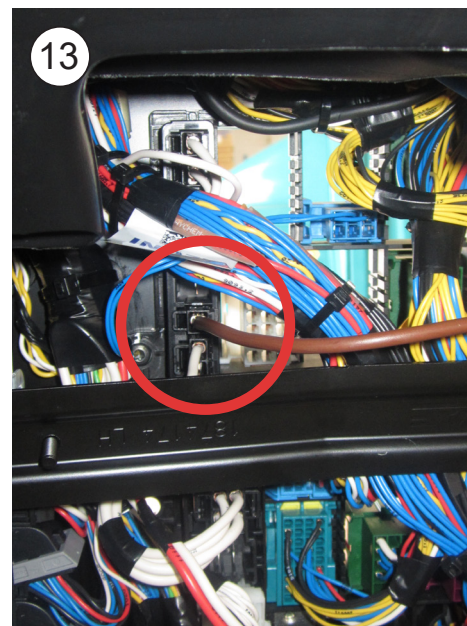
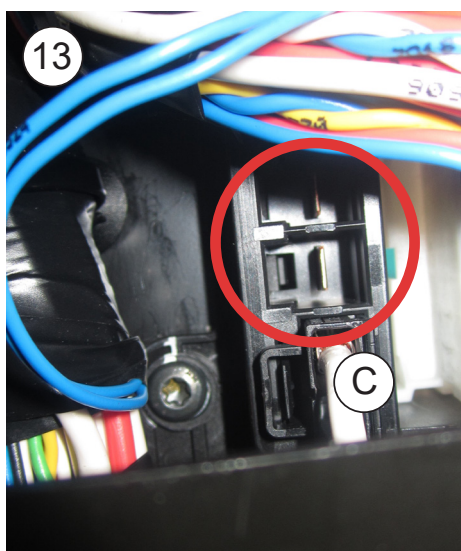
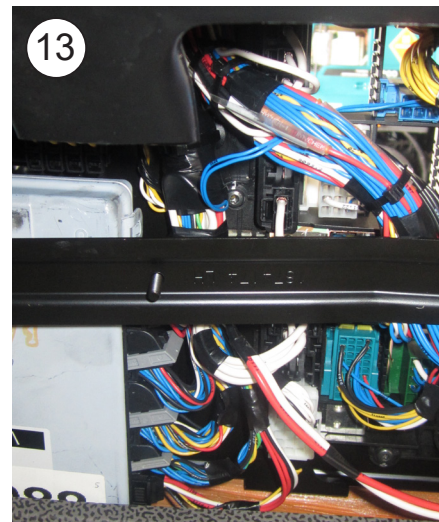

Instructions détaillées sur l'installation du câblage Modèle Euro 6

14

Ouvrir la boîte à gants supérieure droite (D) et démonter le couvercle (E).

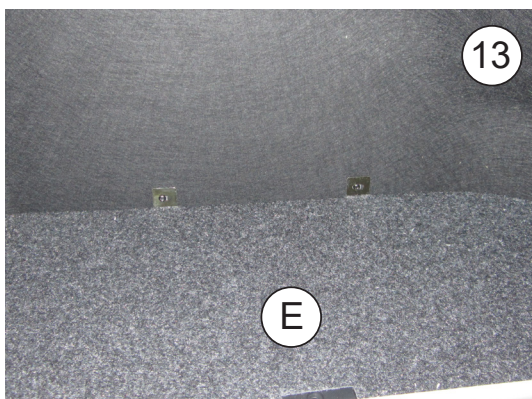
**15**

À travers le tube cannelé placé sur la partie inférieure du côté du passager, introduire le câble Az et M et le sortir par l'extrémité du tube qui ressort par la boîte à gants supérieure droite.

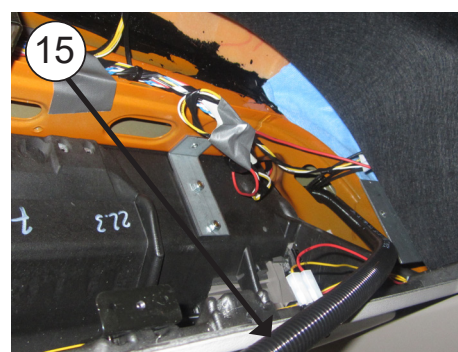
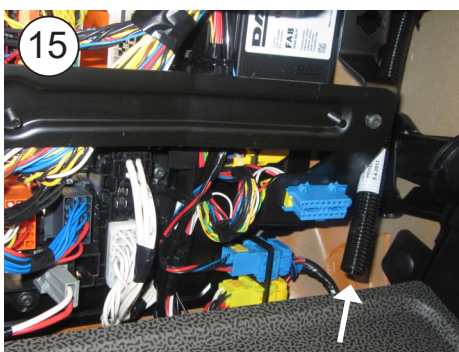
**16**

Agrafer les terminaux fournis aux câbles Az et M et les introduire dans la boîte fournie en faisant coïncider les couleurs avec celles de la boîte du câblage fourni.

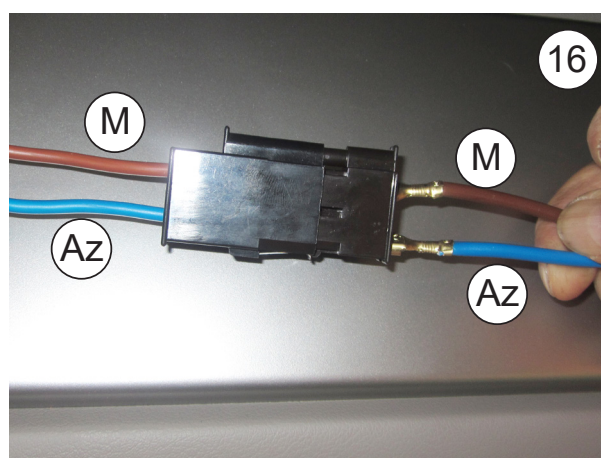

Instructions détaillées sur l'installation du câblage Modèle Euro 6

17

Connecter les boîtes de câblage et porter le câblage derrière les boîtes à gants d'origine et la tapiserie jusqu'à l'équipement et effectuer une connexion avec ce dernier.

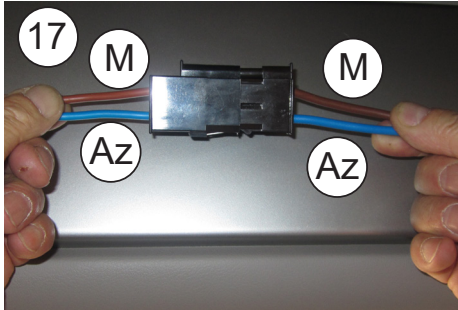
**18**

Dans le cas des véhicules DAF XF 105 Space Cab fabriqués depuis le 10/09/2012, il est nécessaire de remplacer les hexagones M-H M6 L78 et L36 filetés à la base de l'équipement par les hexagones M-H M6 de L68 et L26 respectivement avant de monter la console. Voir les schémas ci-joints.

DAF XF 105 Super Space Cab EURO 5 et EURO 6

Vue décomposée latérale jusqu'à la fixation des consoles

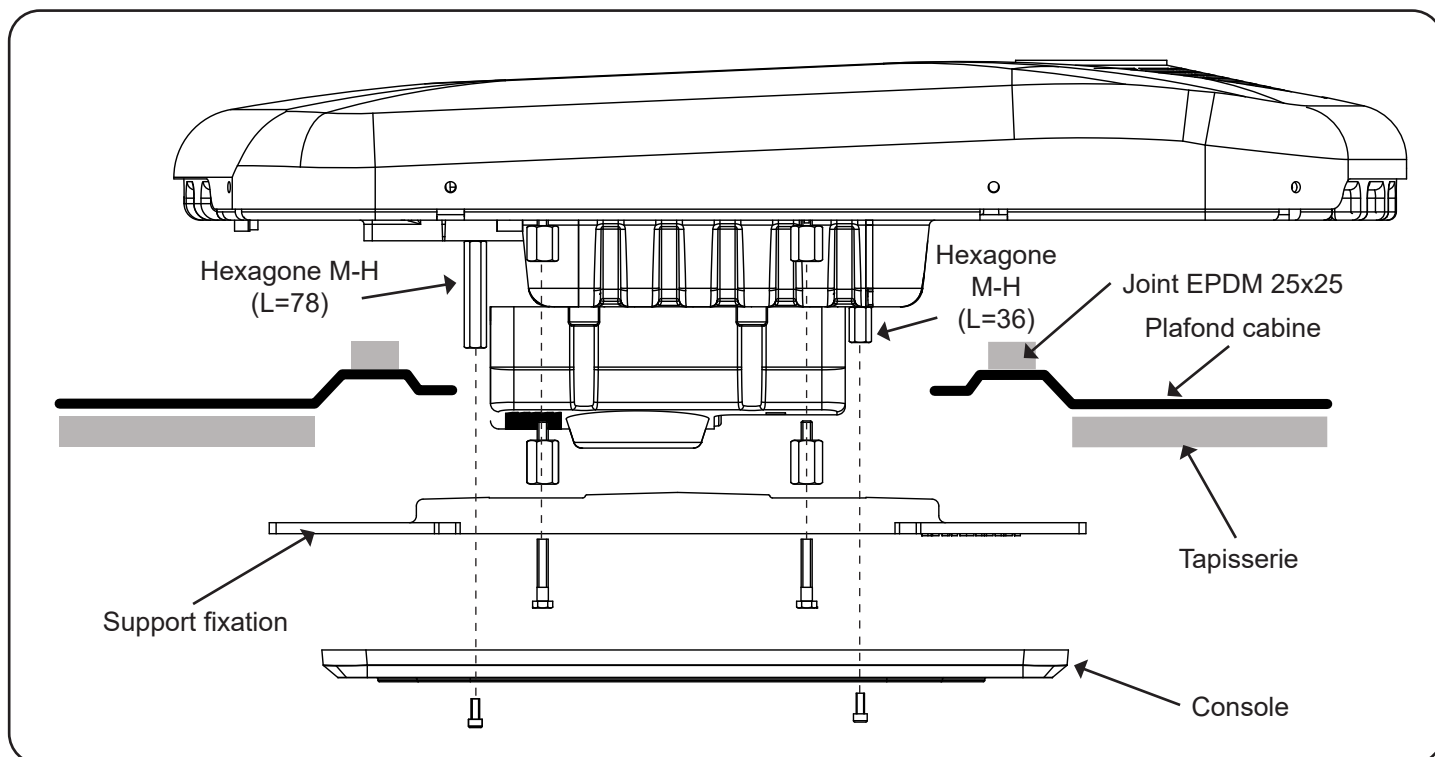

Vue décomposée frontale jusqu'à la fixation des consoles

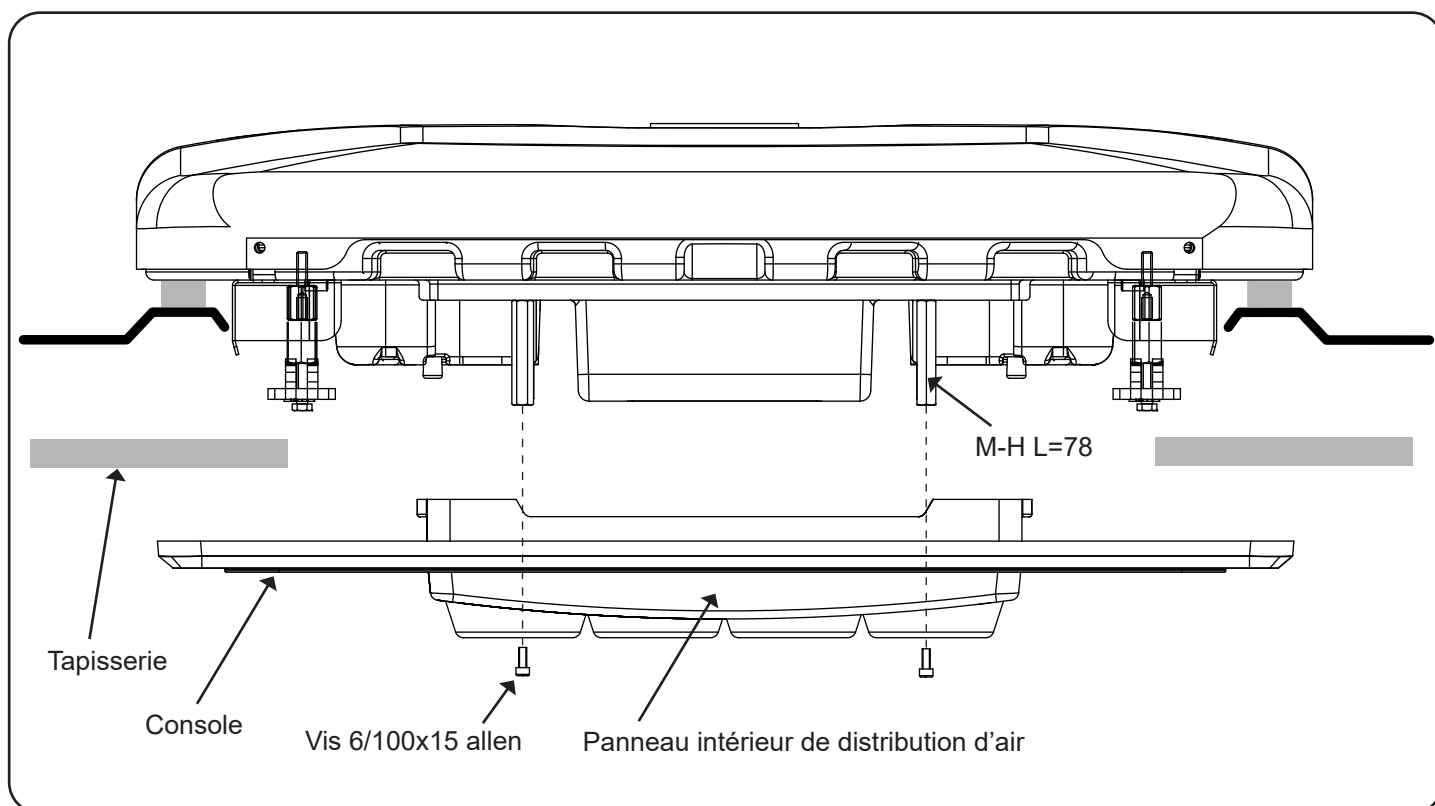

DAF XF 105 Space Cab Euro 5 spoiler non ajustable
DAF XF 105 Space Cab EURO 6

Vue décomposée latérale jusqu'à la fixation des consoles

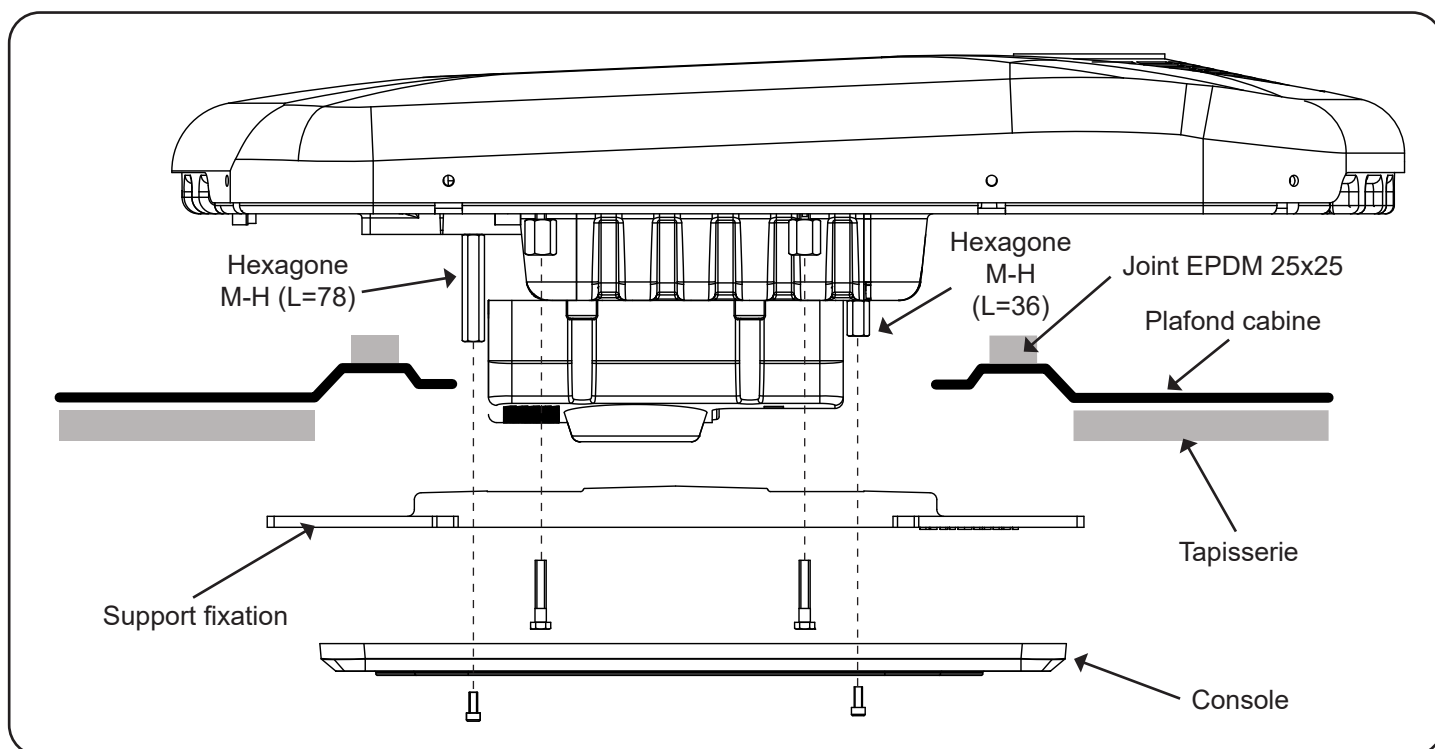

Vue décomposée frontale jusqu'à la fixation des consoles

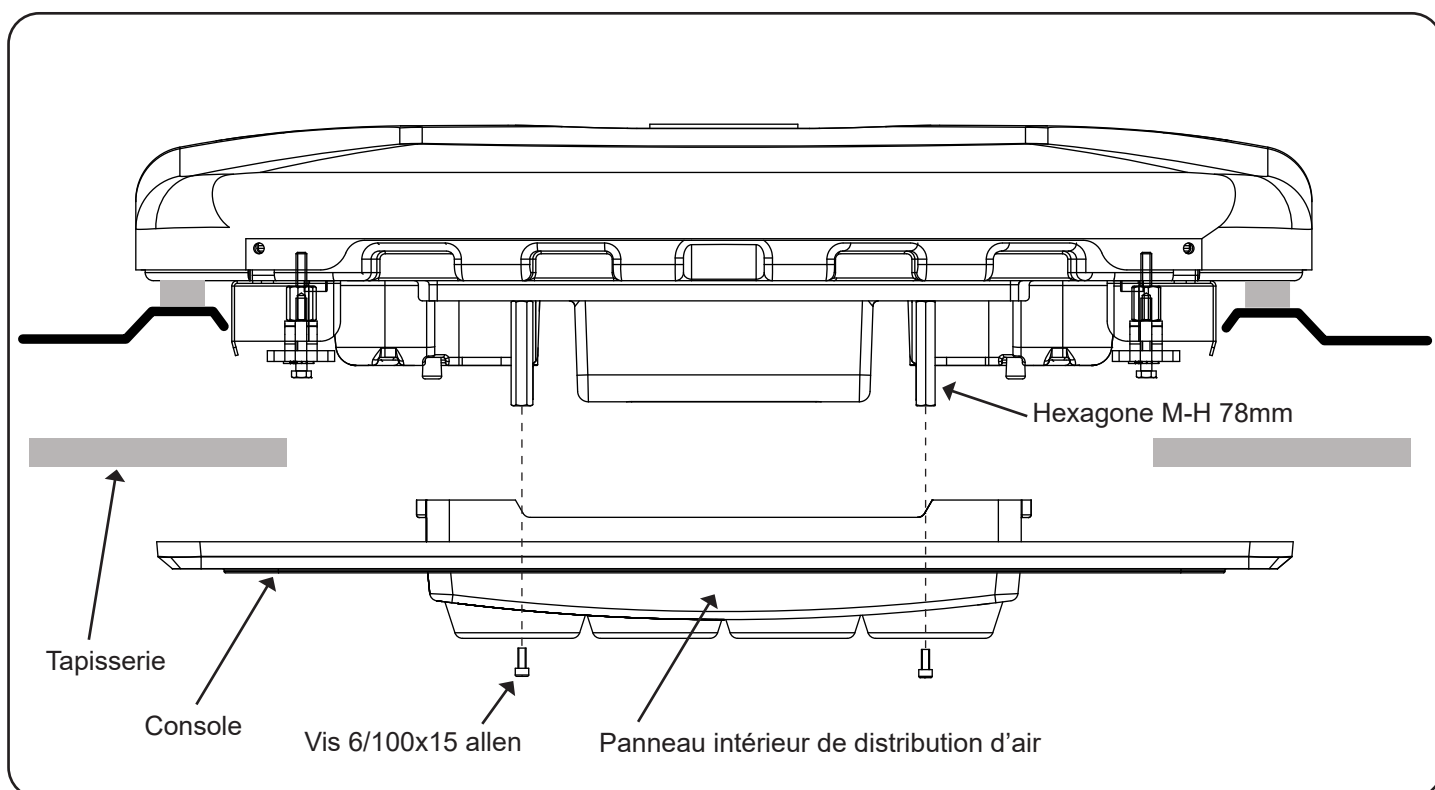

DAF XF 105 Space Cab EURO 5 spoiler ajustable

Vue décomposée frontale jusqu'à la fixation des consoles

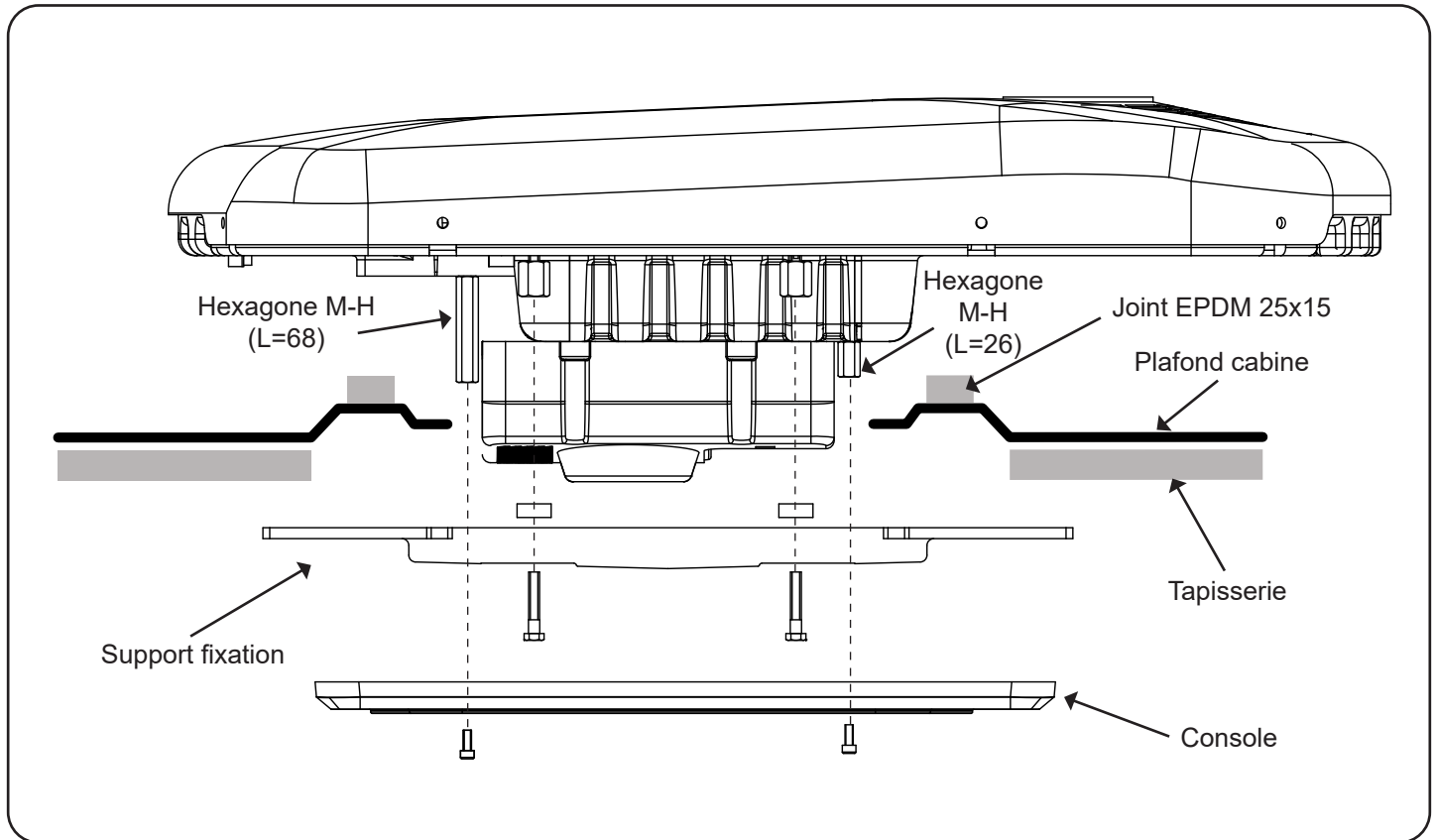

Vue décomposée frontale jusqu'à la fixation des consoles

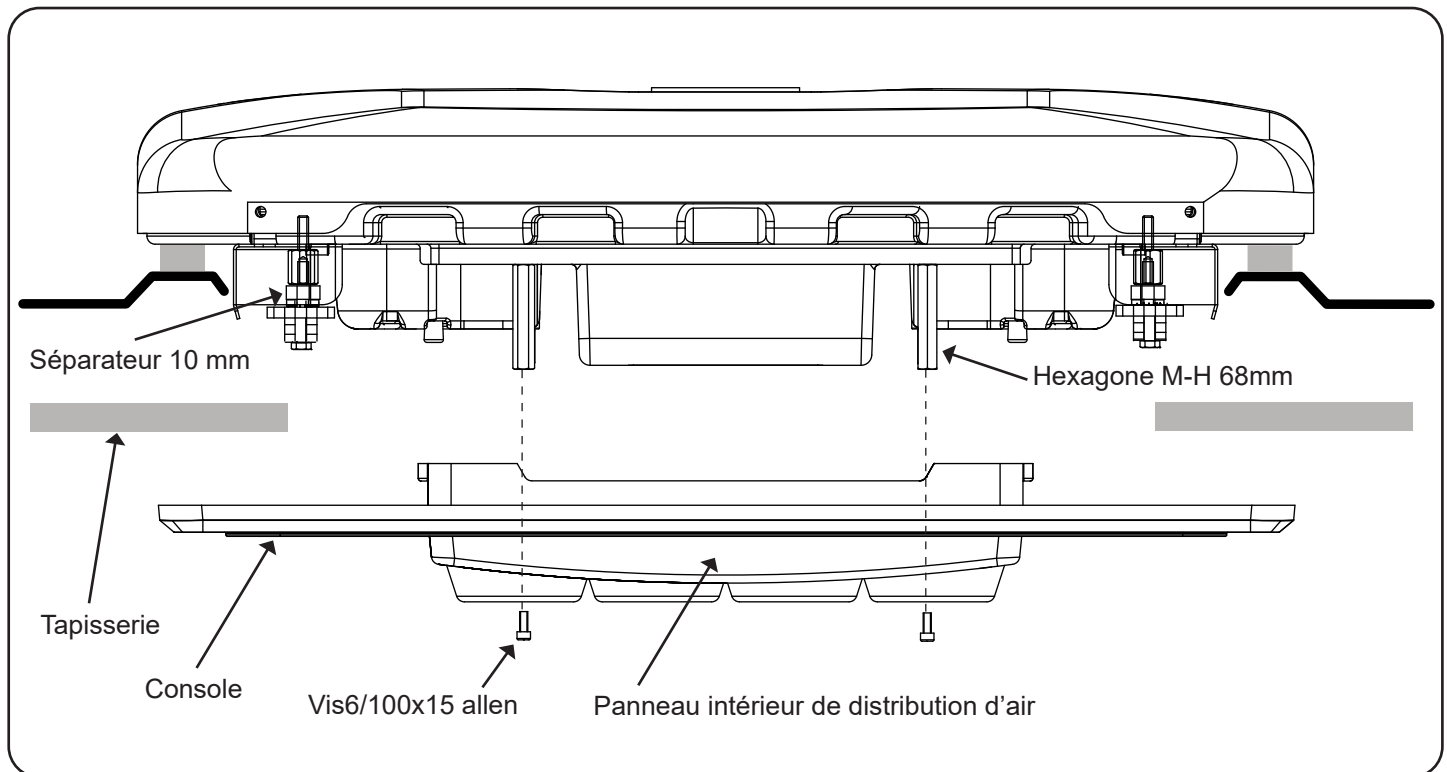

TOUS LES MODÈLES

18

Monter à nouveau les enjoliveurs d'origine à leur place.

Monter la console sur les hexagones H-H avec (4) vis 6/100x15 allen, en plaçant la partie la plus courte de la console sur la partie avant de la cabine.

**19**

Couvrir les (4) vis M6/100x15 allen avec les enjoliveurs ronds de M6 en plastique.



TOUS LES MODÈLES AVEC PRISE ORIGINALE DANS ÉCOUTILLE

Schéma électrique

AVIS IMPORTANT!

Veiller à ne pas inverser les polarités lors du branchement de l'alimentation sur l'appareil, l'affichage ne s'allume pas et l'appareil ne fonctionne pas.

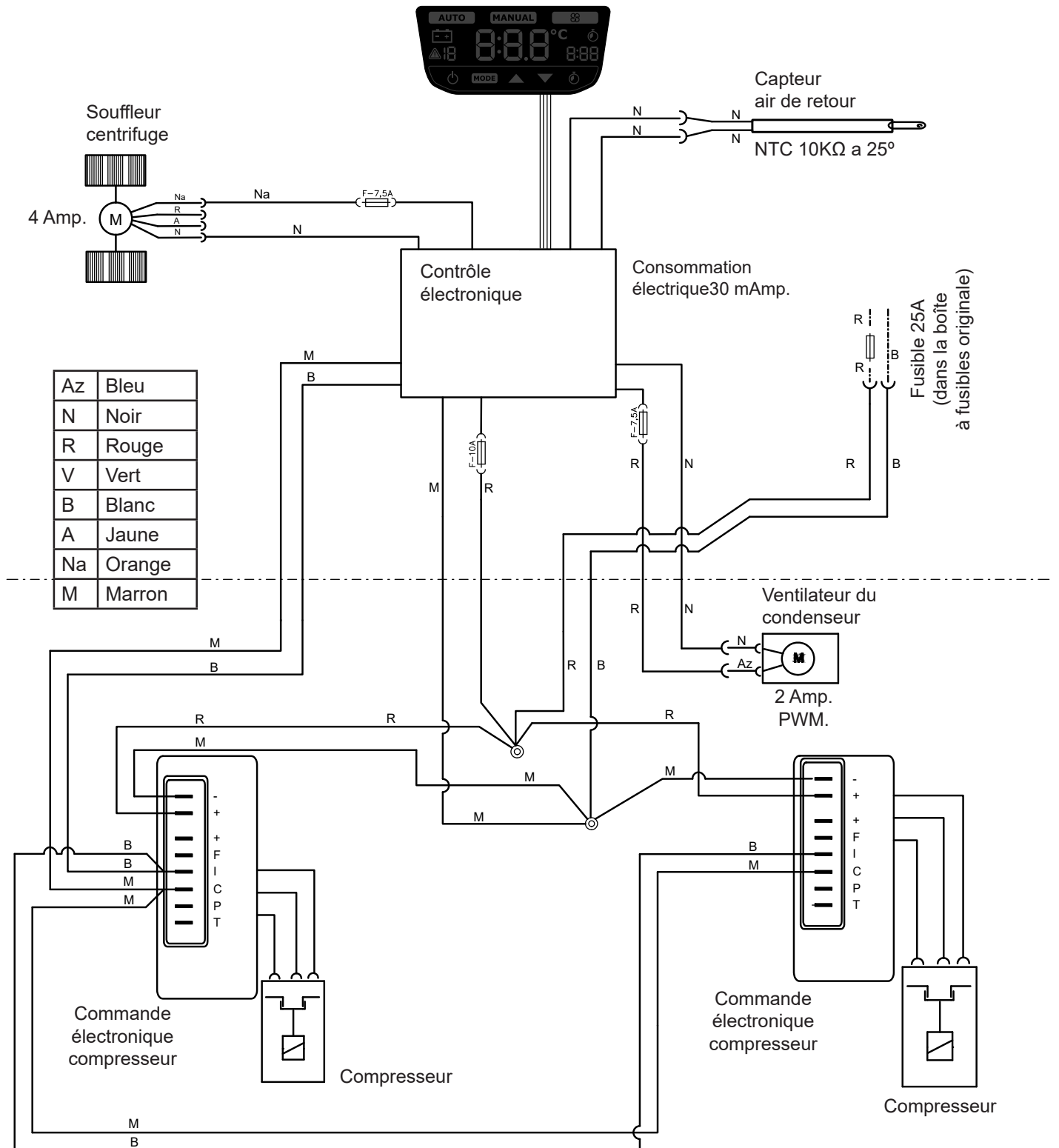

TOUS LES MODÈLES EURO 5 DERRIÈRE LA BOÎTE À GANTS

Schéma électrique

AVIS IMPORTANT!

Veiller à ne pas inverser les polarités lors du branchement de l'alimentation sur l'appareil, l'affichage ne s'allume pas et l'appareil ne fonctionne pas.

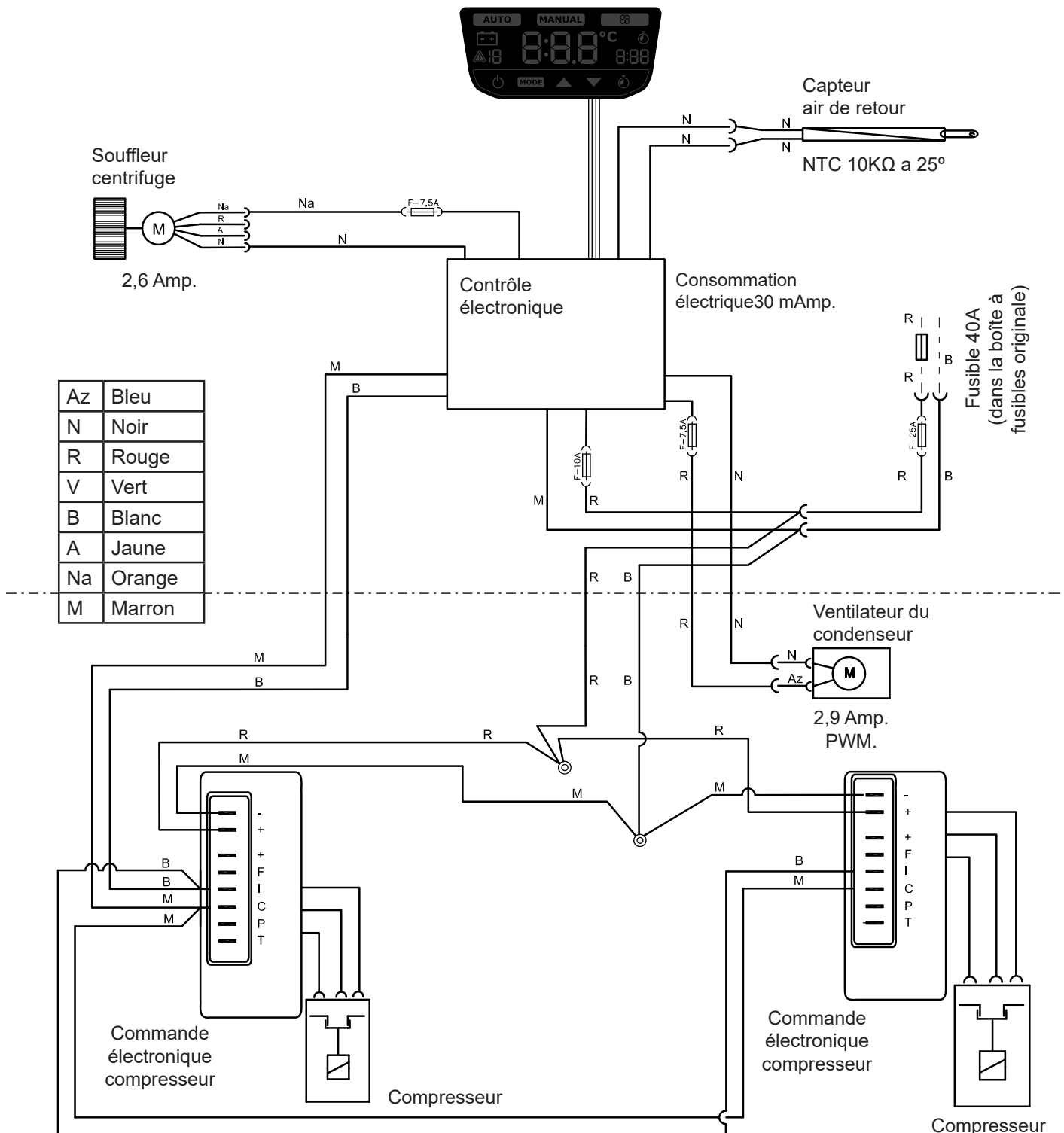

TOUS LES MODÈLES EURO 6 SANS PRISE ORIGINALE DANS ÉCOUTILLE - Schéma électrique

AVIS IMPORTANT!

Veiller à ne pas inverser les polarités lors du branchement de l'alimentation sur l'appareil, l'affichage ne s'allume pas et l'appareil ne fonctionne pas.

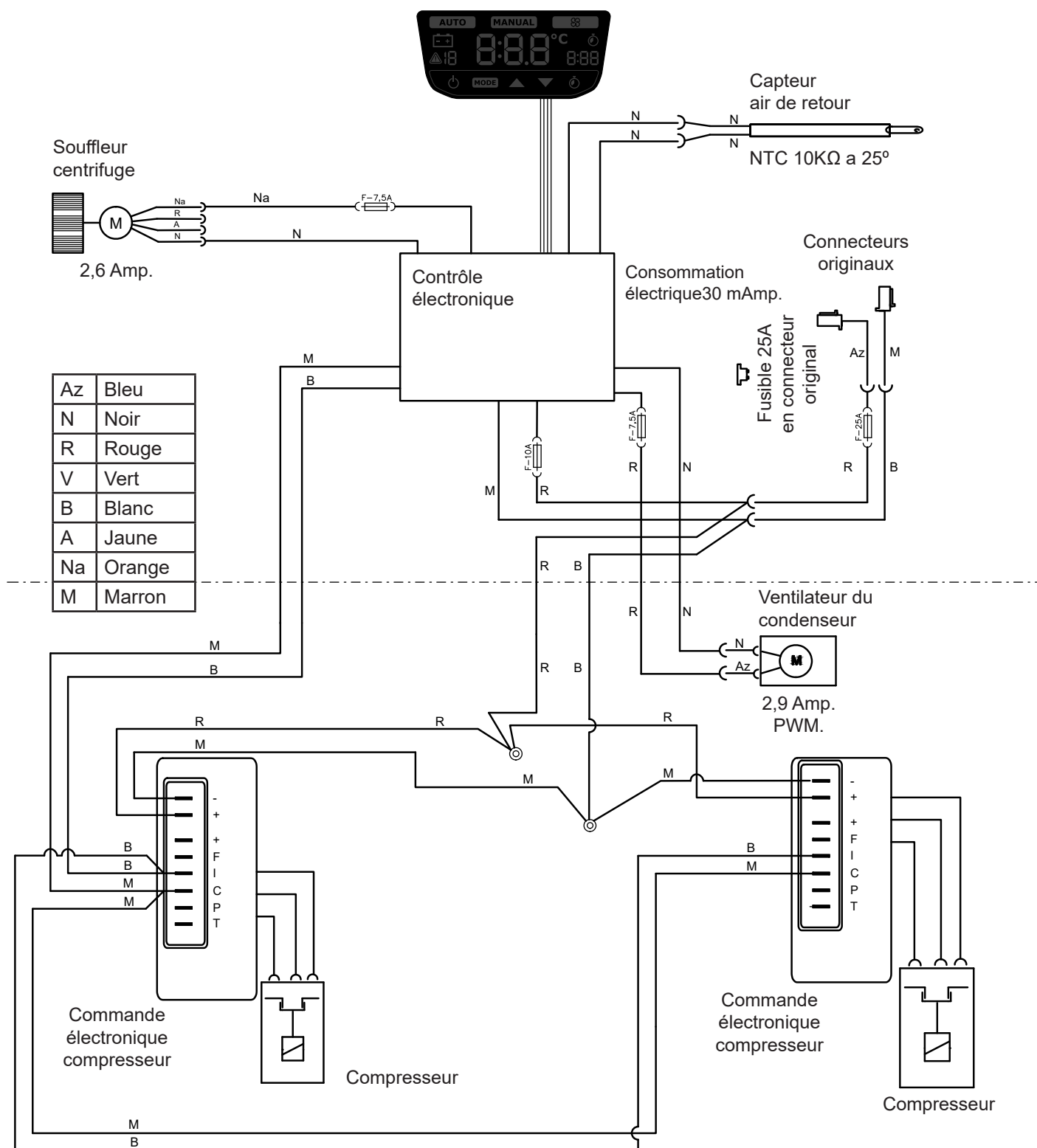

| | |
|-----|------------|
| Ed: | 05/07/2023 |
| Md: | |



Francisco Alonso, 6
28806 Alcalá de Henares, Madrid
SPAIN

| Contact | Phone | Fax | E-Mail |
|--|------------------|------------------|--|
| Sales (Ventas Internacional) | +34 91 8770510 | +34 91 8771158 | sales@dirna.bergstrominc.com |
| Comercial Nacional | +34 91 8775841 | +34 91 8836321 | ventas@dirna.bergstrominc.com |
| Orders & Deliveries (Logística internacional) | +34 91 8775846 | +34 91 8771158 | export@dirna.bergstrominc.com |
| Orders & Deliveries (Logística nacional) | +34 91 8775840 | +34 91 8836321 | comercial@dirna.bergstrominc.com |
| Technical Assistance (Internacional) | +49 511 86679681 | +49 511 86679710 | technicalassistance@dirna.bergstrominc.com |
| Technical Assistance (Nacional) | +34 91 8775845 | +34 91 883 6321 | oblanco@dirna.bergstrominc.com |

www.dirna.com

| | | |
|--|--------------------|--|
| | ATENCIÓN: | Bergstrom se reserva el derecho de efectuar modificaciones en cualquier momento de los datos contenidos en esta publicación, por razones técnicas o comerciales. |
| | NOTE: | <i>For technical and commercial reasons, Bergstrom reserves the right to change the data contained in this brochure.</i> |
| | ATTENTION: | Bergstrom se réserve le droit d'effectuer à tout moment des modifications des données reprises sur cette publication, pour des raisons techniques ou commerciales. |
| | HIWEIS: | <i>Bergstrom behält sich vor, aus technischen oder kaufmännischen Gründen jederzeit Änderungen der Angaben dieser Veröffentlichung vorzunehmen.</i> |
| | ATTENZIONE: | Bergstrom si riserva il diritto di effettuare modifiche in qualsiasi momento ai dati contenuti in questa pubblicazione, per motivi tecnici o commerciali. |